

RESTRICTED

*DEPARTMENT OF THE ARMY TECHNICAL MANUAL
TM 9-297*

This manual supersedes TM 9-297, 16 December 1948

**3.5-INCH
ROCKET LAUNCHERS
M20 AND M20B1**



DEPARTMENT OF THE ARMY • AUGUST 1950

*United States Government Printing Office
Washington : 1950*

RESTRICTED

DEPARTMENT OF THE ARMY
WASHINGTON 25, D. C., 10 August 1950

TM 9-297 is published for the information and guidance of all concerned.

[AG 471.94 (8 Aug 50)]

BY ORDER OF THE SECRETARY OF THE ARMY:

OFFICIAL:

J. LAWTON COLLINS

EDWARD F. WITSELL *Chief of Staff, United States Army*
Major General, USA
The Adjutant General

DISTRIBUTION:

Tech Sv (2) except 9 (25); Arm & Sv Bd (2); AFF (2); OS Maj Comd (10); Base Comd (2); MDW (3); A (20); CHQ (2); D (2); R 2, 6, 7, (1), 9 (2); Bn 2, 3, 5, 6, 7 (1), 9 (2), 11, 17, 44 (1); C 2, 3, 5, 6, 7 (1), 9 (2), 10, 11, 17, 44 (1); FC (1); Sch (5) except 9 (50); Gen Dep (1); Dep 9 (3); PE (Ord O) (5), OSD (1); PG 9 (3); Ars 9 (3); Dist 9 (3); T/O & E 4-157 (1); 10-118 (1); SPECIAL DISTRIBUTION.

For explanation of distribution formula see SR 310-90-1.

CONTENTS

	Paragraph	Page
CHAPTER 1. INTRODUCTION.		
<i>Section I.</i> General.....	1-2	1
<i>II.</i> Description and data.....	3-6	2
CHAPTER 2. OPERATING INSTRUCTIONS.		
<i>Section I.</i> General.....	7	10
<i>II.</i> Service upon receipt of equipment.....	8-10	10
<i>III.</i> Launcher controls and sighting equipment.....	11-20	11
<i>IV.</i> Operation under usual conditions.....	21-25	19
<i>V.</i> Operation under unusual conditions.....	26-29	25
CHAPTER 3. MAINTENANCE INSTRUCTIONS.		
<i>Section I.</i> General.....	30-31	27
<i>II.</i> Parts, special tools, and equipment for organiza- tional maintenance.....	32-33	27
<i>III.</i> Lubrication.....	34-35	28
<i>IV.</i> Preventive maintenance service.....	36-41	33
<i>V.</i> Trouble shooting.....	42-43	36
<i>VI.</i> Front and rear barrel group.....	44-46	37
<i>VII.</i> Firing mechanism.....	47-49	57
<i>VIII.</i> Monopod stock assembly.....	50-52	64
<i>IX.</i> Sighting equipment.....	53-58	69
CHAPTER 4. AUXILIARY EQUIPMENT.		
<i>Section I.</i> General.....	59	84
<i>II.</i> Ammunition.....	60-67	84
CHAPTER 5. MAINTENANCE EQUIPMENT.		
<i>Section I.</i> General.....	68	95
<i>II.</i> Parts, special tools, and equipment for field and depot maintenance.....	69-71	95
<i>III.</i> Firing mechanism electrical output tester.....	72-73	96
CHAPTER 6. SHIPMENT AND LIMITED STORAGE AND DE- STSTRUCTION TO PREVENT ENEMY USE.		
<i>Section I.</i> Shipment and limited storage.....	74-76	100
<i>II.</i> Destruction of matériel to prevent enemy use.....	77-79	106
APPENDIX. REFERENCES.		109

RESTRICTED

This manual supersedes TM 9-297, 16 December 1948

CHAPTER 1 INTRODUCTION

Section I. GENERAL

1. Scope

a. These instructions are published for the information and guidance of all concerned.^{1 2} They contain information on the operation and organizational maintenance of the 3.5-inch rocket launcher M20, as originally manufactured and as modified, and on the 3.5-inch rocket launcher M20B1. The information in this manual is intended for the using arms and services, however, certain testing, adjusting, and maintenance information on this weapon for ordnance maintenance personnel is included. Description of major units and their functions in relation to other components of this weapon also are included.

b. The appendix at the end of the manual contains a list of references including supply catalogs, technical manuals, and other publications applicable to the weapon.

c. In all cases where the nature of repair, modification, or adjustment is beyond the scope or facilities of the unit, the responsible ordnance maintenance service will be informed so that trained personnel with suitable tools and equipment may be provided or proper instructions issued.

d. This manual differs from TM 9-297, 16 December 1948, as follows:

(1) Adds information on—

Oval reticle pattern C7677030 and ladder reticle pattern C7677491 and the elevation plate C7141998 associated with the latter.

Modifications of the M20 launcher affecting the bipod assembly, trigger guard, slide block catch, and electrical firing mechanism.

3.5-inch rocket launcher M20B1.

Testing of double action electrical firing mechanism.

(2) Revises information on testing of single action electrical firing mechanism.

¹ To provide operating instructions with the matériel, this technical manual has been published in advance of complete technical review. Any errors or omissions will be corrected by changes or, if extensive, by an early revision. Comments, suggestions, and recommendations for changes will be forwarded to Chief of Ordnance, Washington 25, D. C., Attention: ORDFM-Pub.

² As no production models of the M20B1 or the modified M20 launchers were available prior to publication, the illustrations were made from development models. Differences may be noted between the illustrations herein and the actual production line models.

2. Records

a. FIELD REPORT OF ACCIDENTS.

- (1) *Injury to personnel or damage to matériel.* The reports necessary to comply with the requirements of the Army safety program are prescribed in detail in the SR 385-10-40 series of special regulations. These reports are required whenever accidents involving injury to personnel or damage to matériel occur.
- (2) *Ammunition.* Whenever an accident or malfunction involving the use of ammunition occurs, firing of the lot which malfunctions will be immediately discontinued. In addition to any applicable reports required in (1) above, details of the accident or malfunction will be reported as prescribed in SR 385-310-1.

b. **UNSATISFACTORY EQUIPMENT, REPORT.** Any suggestion for improvement in design, maintenance, safety, and efficiency of operation prompted by chronic failure or malfunction of the matériel, spare parts, or equipment, or as to defects in the application or effect of prescribed lubricants and/or preserving materials will be reported through technical channels to the Chief of Ordnance, Washington 25, D. C., ATTENTION: ORDFM, using DA AGO Form 468, "Unsatisfactory Equipment Report." Such suggestions are encouraged in order that other organizations may benefit.

Section II. DESCRIPTION AND DATA

3. Description

a. The 3.5-inch rocket launchers M20 (fig. 6) and M20B1 (figs. 4 and 5) are two-piece smooth-bore weapons of the open tube type and are fired electrically. The weapons are arranged to be fired from the shoulder in standing, kneeling, and sitting positions. A bipod and rear support permit firing in the prone position (fig. 3). To save weight and improve portability, the barrels and many other parts are made of aluminum. These launchers are used to launch smoke rockets and high-explosive rockets against ground targets. The high-explosive antitank rockets are capable of penetrating heavy armor at angles of impact up to 30 degrees. The weapons are sighted on the target by means of a reflecting sight mounted on the launcher. In firing position, the front and rear barrel assemblies comprising each launcher are joined in tandem to form a launching tube. In carrying position, the barrels are fastened together in a double tube arrangement thereby eliminating the unwieldy length of the assembled weapon (fig. 9). The front barrels of any two 3.5-inch rocket launchers, whether they



Figure 1. 3.5-inch Rocket Launcher M20B1—fired from standing position.



Figure 2. 3.5-inch Rocket Launcher M20B1—fired from sitting position.



Figure 3. 3.5-inch Rocket Launcher M20B1—fired from prone position.

are of the same model number or not, are interchangeable. However, the launcher must be boresighted after the barrels are interchanged. A gun sling is used as an accessory for carrying the launcher. A magneto-type firing device in the trigger grip provides the current for igniting the rockets.

b. The primary functions of a launcher are to ignite the propellant of the rocket and give direction to its initial flight. Reactive forces on the launcher are slight since the propulsion of the rocket is accomplished by the jet action of the propellant powder in the motor body of the rocket and does not depend upon gas pressure built up inside the launcher tube. The launcher tube, therefore, need be only heavy enough to prevent denting or bending during handling and to prevent excessive heating at normal rates of fire.

c. When the propellant is ignited, gases and flames are blown from the breech of the launcher. The area directly in rear of the launcher must be clear of personnel or of inflammable material (par. 22a). Because of the rear blast of the weapon, the gunner must take special precautions to avoid injury when firing from the prone position (par. 21b).

4. Differences Between Models

a. The difference between the 3.5-inch rocket launcher M20 and M20B1 is that the front and rear barrels of the M20 are fabricated from aluminum tube stock with parts such as the muzzle deflector, breech guard, barrel coupling, screw and nut, etc., fastened to the barrels by screws while the front and rear barrels of the M20B1 are aluminum castings produced by the permanent mold process and many of the parts are cast integral with the barrels effecting a slight saving in over-all weight (see NOTE following par. 44f).

b. Three different reticle patterns and two different elevation plates have been supplied with M20 launchers. The concentric ring reticle pattern of reflecting sight assembly D7313440 is described in paragraph 54e (1). The elliptical reticle pattern of reflecting sight assembly D7162890 is described in paragraph 54e (2). The latter type reticle pattern of reflecting sight assembly D7141999 and its corresponding elevation plate C7141998 are described in paragraphs 20a (3) and 54e (3). The elevation plate C7138366 associated with the concentric ring and oval reticle patterns is described in paragraph 20a (2).

c. 3.5-inch rocket launchers M20 of early manufacture were supplied with bipod assemblies having continuous front and rear rings. The bipod assemblies of M20 launchers of later manufacture and M20B1 launchers have split front rings held together by a screw and nut to facilitate removal of the bipod assembly from the front barrel. The rear ring clamp of the bipod assemblies of later manu-

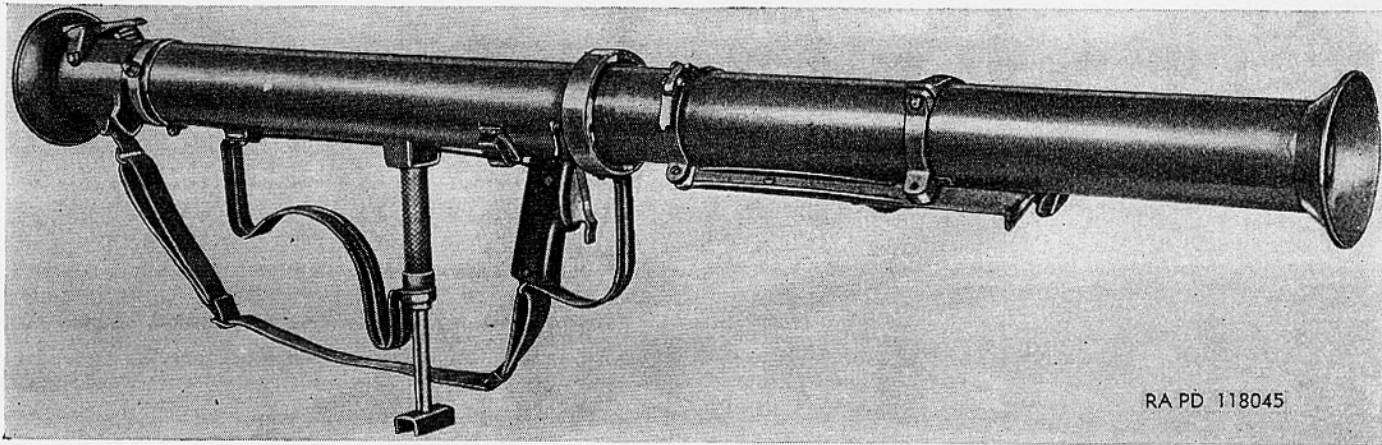

RA PD 118045

Figure 4. 3.5-inch Rocket Launcher M20B1—bipod folded.

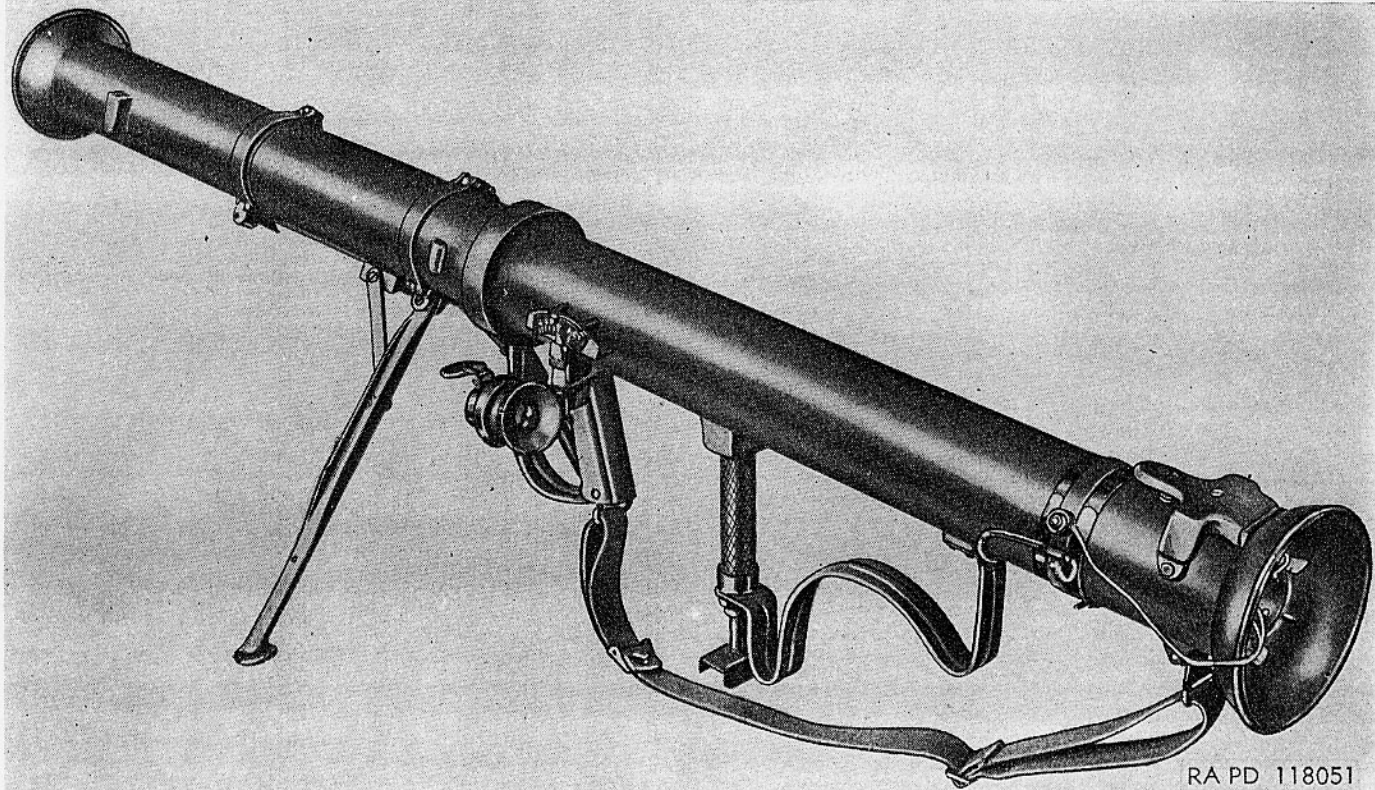

RA PD 118051

Figure 5. 3.5-inch Rocket Launcher M20B1—launcher in firing position.

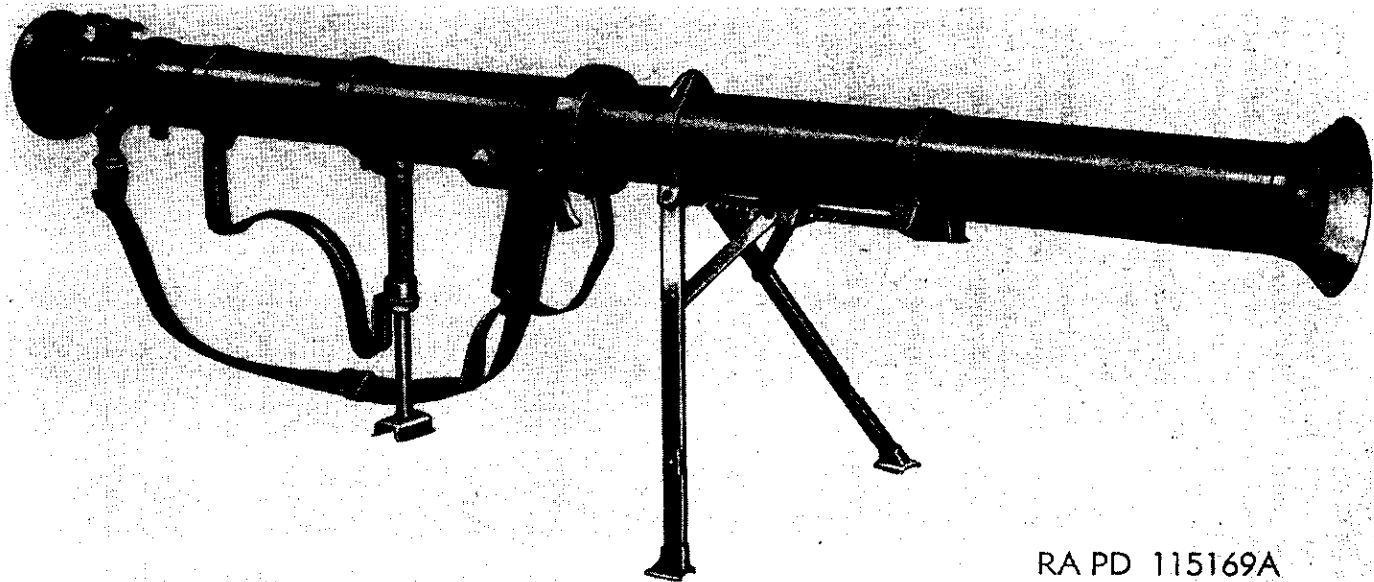

RA PD 115169A

Figure 6. 3.5-inch Rocket Launcher M20—bipod extended.

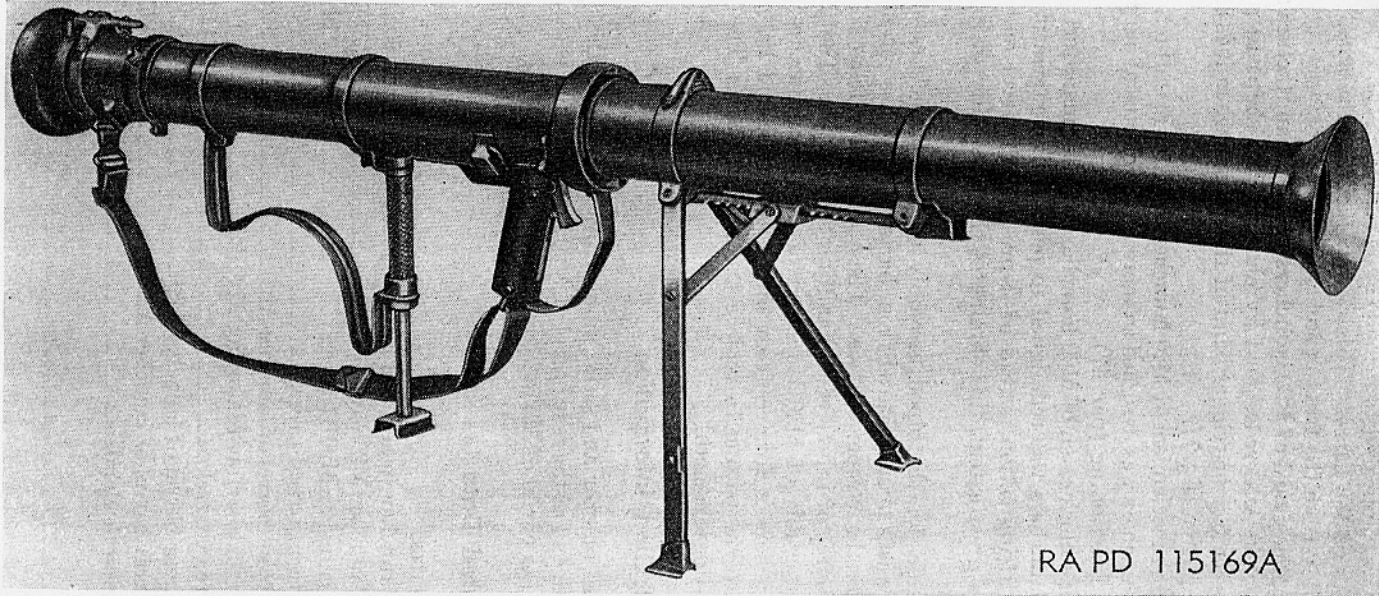

RA PD 115169A

Figure 6. 3.5-inch Rocket Launcher M20—bipod extended.

facture also was improved to provide split rear rings, and more positive clamping of the barrel. This design facilitates removal of the bipod assembly from the front barrel.

d. The trigger guard of M20 launchers of later manufacture and of M20B1 launchers was redesigned by changing its shape to provide ample clearance for the trigger hand of the gunner when it is encased in an Arctic mitten (fig. 7).

e. The firing mechanism of M20 launchers of later manufacture and of M20B1 launchers was designed to increase the electrical output and improve its functioning (par. 47).

f. The slide block catch of M20 launchers of later manufacture and of M20B1 launchers was redesigned to permit disengagement of the catch by a lifting action instead of depressing the lever end of the catch. To a great extent, this eliminates the possibility of injury to the fingers.

g. The slide for the bipod assembly of M20 launchers of early manufacture was manufactured from bar stock and has ratchet teeth machined on the bottom surface. These exposed ratchet teeth are a possible source of injury when handling the weapon. The slide for the bipod assembly of M20 launchers of later manufacture and of M20B1 launchers is formed from sheet steel stock and has notches stamped into the bottom to replace the ratchet teeth. The bottom face of the slide is smooth.

5. Identification Information

The model number and serial number are stamped on the left side at the breech end of the rear barrel of M20 launchers and is cast on the top of the rear barrel of M20B1 launchers.

6. Tabulated Data

a. LAUNCHER.

Length of launcher (assembled for firing)	60.25 inches
Weight of launcher M20 (aprx)	15 pounds
Weight of launcher M20B1 (aprx)	14 pounds
Length of front barrel (aprx)	30 inches
Weight of front barrel of launcher M20	6.1 pounds
Weight of front barrel of launcher M20B1	5.75 pounds
Length of rear barrel	31.25 inches
Weight of rear barrel of launcher M20	8.9 pounds
Weight of rear barrel of launcher M20B1	8.25 pounds
Type of firing mechanism	Electric

b. SLING.

Weight	0.24 pound
--------------	------------

c. AMMUNITION.

Types used (par 64a)----- HE, AT and practice
Weight of rocket (aprx)----- 8½ pounds
Range maximum----- 960 yards
Muzzle velocity----- 340 feet per second
Armor penetration----- aprx 11 inches homogeneous armor plate

CHAPTER 2

OPERATING INSTRUCTIONS

Section I. GENERAL

7. Scope

Part two contains information for the guidance of the personnel responsible for the operation of these rocket launchers. It contains information on the preliminary servicing of the launcher and its operation under usual (moderate) and unusual atmospheric conditions. In addition, it contains a description of the launcher controls and sight indicators.

Section II. SERVICE UPON RECEIPT OF EQUIPMENT

8. General

a. Upon receipt of new or used matériel, it is the responsibility of the officer in charge to ascertain whether it is complete and in sound operating condition. Reference to paragraphs 44 through 58 will provide information on the components of the various major groups of the launcher.

b. A record will be made of any missing parts and of any malfunctions. Any such conditions will be corrected as quickly as possible.

c. Attention will be given to small and minor parts as these are the more likely to become lost and may seriously affect the proper functioning of the rocket launcher.

d. The rocket launcher will be cleaned and prepared for service in accordance with the instructions given in paragraphs 9 and 10.

9. New Equipment

a. Remove launcher from the packing box, remove the preservative from all external surfaces with a clean rag, and then wipe with a rag dampened with dry-cleaning solvent or rifle bore cleaner. Clean the bore with waste to remove the preservative. Then saturate a cloth in dry-cleaning solvent or rifle bore cleaner and run through the bore until the preservative has been entirely removed. When thoroughly clean, dry the bore of the barrels as prescribed in paragraphs 34 and 35.

b. Give particular attention to the proper functioning of the following parts when inspecting this equipment (par. 46):

- (1) Contactor latch assembly.
- (2) Barrel coupling lock.
- (3) Barrel latch handle.
- (4) Trigger and safety.
- (5) Monopod.
- (6) Bipod trip.
- (7) Bipod slide block catch.
- (8) Bipod rear ring lock.
- (9) Bipod front ring for free rotation on barrel.

c. Assemble the front and rear barrels (par. 21*a*). They should assemble easily and, when coupled in any of the three locked positions, should be positively locked without play.

d. Boresight the launcher (par. 57).

e. Examine launchers for general appearance. If paint has deteriorated, become glossy, or become damaged, leaving exposed portions of bare metal, the matériel will be repainted (par. 46*h*).

f. Check spare parts and accessories with Department of the Army Supply Catalog ORD 7 SNL B-42.

g. Inspect the auxiliary equipment (refer to ch. 4).

10. Used Equipment

a. In addition to the procedures and inspections prescribed in paragraph 9, used equipment will also be inspected to insure that all modification work orders have been applied.

b. A list of modification work orders is published in SR 310-20-4. If any modification work order has not been applied, the local ordnance officer must be notified promptly.

Section III. LAUNCHER CONTROLS AND SIGHTING EQUIPMENT

11. Trigger

a. The trigger is located in front of the trigger grip (fig. 30). It is made of aluminum.

b. Some rocket launchers M20 are equipped with electric firing mechanism C7313326 (single action—fig. 7). After the trigger of this mechanism is squeezed a spring returns it to its normal position when the trigger is released. The movement of the trigger, when it is squeezed and released, rocks the armature of a magneto firing mechanism which is housed in the trigger grip. The rocker arm and armature provide snap action to the movement of the armature.

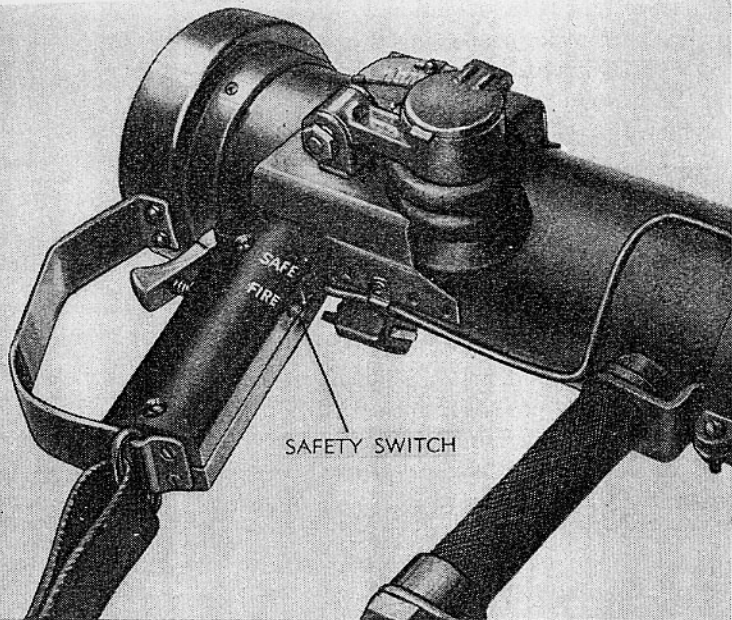

FIRING MECHANISM—C7313326 (SINGLE ACTION)

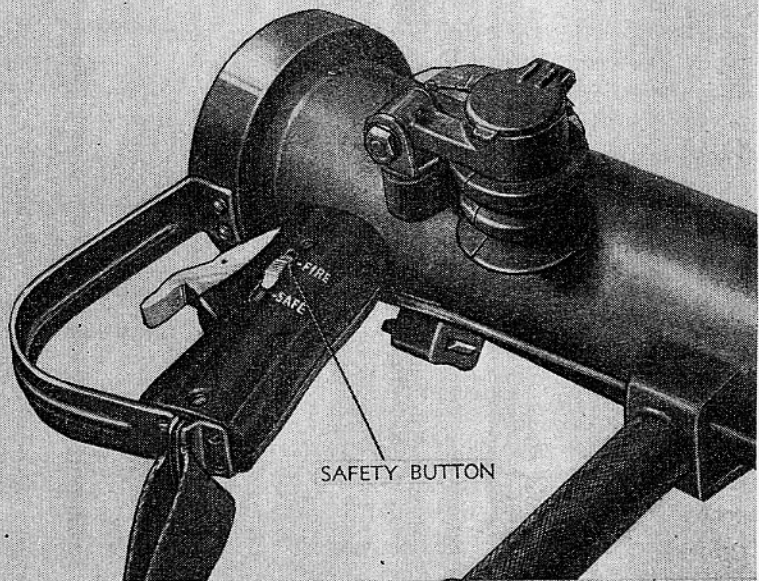

FIRING MECHANISM—B7140325 (DOUBLE ACTION)

RA PD 118077

Figure 7. Firing mechanisms.

c. Some rocket launchers M20 and rocket launchers M20B1 are equipped with electric firing mechanism B7140325. In this mechanism also, the return of the trigger to its normal (forward) position is accomplished by spring action after it has been squeezed and released. This mechanism not only imparts snap action to the rocking of the armature in the magneto coil but produces a complete cycle of the armature, by sign action, when the trigger is squeezed. The return motion of the trigger when it is released does not generate any electric current.

d. In both firing mechanisms movement of the magneto armature generates electric current which is used to ignite the rocket (see pars. 47-49).

12. Safety

a. Some launchers M20 are equipped with firing mechanism C731326 single action-fig. 7) and are each provided with a safety switch.

- (1) The safety switch is located on the rear of the trigger grip (fig. 7) where it is handy for manipulation by the thumb of the right hand. The safety switch button is brass.
- (2) The safety switch has two positions. The upper position is its "SAFE" position. In this position the switch functions to shunt (short circuit) the current and so prevent it from reaching the igniter of the rocket. The lower position of the safety switch is its "FIRE" position. In this position the switch functions to open the shunt permitting the current to reach the igniter of the rocket. Markings on the left grip (fig. 7) indicate the two positions of the safety switch (pars. 47-49).

b. Some launchers M20 and launchers M20B1 are equipped with firing mechanism B7140325 (double action-fig. 7) which is provided with a safety button.

- (1) The safety button is located in a slot in the left grip (figs. 7 and 29) where it is handy for manipulation by the thumb of the right hand. The safety button is aluminum.
- (2) The safety button has two positions. The lower position is its "SAFE" position. In this position the block of the safety mechanism is interposed behind a protruding lug of the trigger and locks the trigger. The upper position of the safety button is its "FIRE" position. In this position the block of the safety mechanism is held clear of the lug on the trigger and the trigger is free to move.

Caution: Whenever firing is not being attempted, the safety must be kept in its "SAFE" position.

13. Barrel Coupling Lock Lever

a. The barrel coupling lock lever is located on the right side of the rear barrel assembly just behind the barrel coupling nut (figs. 18 and 20). It is made of steel.

b. The barrel coupling lock lever is used to release the barrel coupling lock and must be operated when assembling the front and rear barrel assemblies into firing position (par. 21) and when breaking the weapon into carrying position (par. 25). It is operated by raising and holding the lever in its unlocked position. When the lever is released, a spring returns it to its locked position.

14. Barrel Latch Handle

a. The barrel latch handle is located on the right side of the rear barrel assembly just back of the trigger grip (figs. 18 and 20). The handle is aluminum.

b. The barrel latch handle is used to release the barrel latch which locks the front and rear barrel assemblies in carrying position. Moving the handle forward retracts the barrel latch bolt causing it to release the barrel latch strike (on the front barrel assembly). Two springs on the barrel latch bolt (fig. 26) keep the bolt in its normal extended position. When the barrel hook of the front barrel assembly is engaged in the barrel eye of the rear barrel assembly and the barrels are pressed together, the bolt latches the strike. This fastens the barrels together in carrying position, and the barrel latch handle must be pressed forward to release the latch in order to separate the barrels (par. 25).

Note.—Such parts as the barrel hook and eye and the barrel strike occur as parts only in the M20 launcher. In the M20B1 launcher, the functions of these parts are effected by shapes cast integral with the barrels.

15. Monopod Sleeve Body

a. The monopod sleeve body is the cylindrical, knurled part of the monopod (figs. 18 and 20).

b. The monopod sleeve body is used to adjust the height of the monopod. Clockwise rotation of the sleeve body, as viewed from the bottom, extends the monopod, and vice versa (par. 21*b*). When the launcher stands on the bipod and monopod, adjustment of the height of the monopod is a stable means of controlling elevation of the weapon (sec. VIII, ch. 3).

16. Bipod Trip

a. The bipod trip is located at the bipod front ring (figs. 16 and 17). It is made of aluminum. The leg lock buttons of the bipod front ring

assembly act as detents to hold the bipod in folded position against the front barrel.

b. The bipod trip serves to pry the bipod legs free of the lock buttons for unfolding. Pulling the trip away from the barrel pries the bipod legs free. "PULL" is marked on the trip to indicate this operation (par. 21*b* (1)).

c. Two springs on the trip pin hold the trip in its normal position, flat against the barrel (par. 46*f*).

17. Bipod Slide Catch

a. The bipod slide is mounted on the front and rear rings of the bipod assembly. The slide block moves along the slide as the bipod is folded and unfolded. The bipod slide block catch is pivoted on the under side of the slide block and engages either ratchet teeth or notches on the underside of the slide (fig. 8). The slide and slide block catch are made of steel.

b. The bipod slide block catch of some M20 launchers is released by pressing the lever end of the catch up against the slide block. The catch then swings free of the ratchet teeth or notches on the slide. A spring on the catch pivot pin keeps the catch pressed against the slide.

c. The bipod slide block catch, of some M20 launchers and of M20B1 launchers, may also be released by pulling the catch down out of engagement with the ratchet or notches on the underside of the slide, as well as by pressing the lever end of the catch up against the slide block as described in *b* above. A spring on the catch pivot pin keeps the catch pressed against the slide.

d. The slide block catch must be released to permit folding the bipod but the ratchet or notches permit unfolding of the bipod without touching the catch. By engaging the ratchet or notches of the slide, the slide block catch will hold the bipod against folding in any position to which the bipod is extended.

18. Bipod Rear Ring Lock Handle

a. The rear ring lock handles of all the 3.5-inch rocket launchers M20 and M20B1 are operated in similar fashion although the design has been modified. On M20 launchers of early manufacture the bipod rear ring lock handle is located at the top of the bipod rear ring (fig. 23) (directly opposite the slide). On M20 launchers of later manufacture and on M20B1 launchers the bipod rear ring lock handle is located on the left side near the top of the rear ring (fig. 24).

b. To release the bipod rear ring lock, raise the lock handle. To lock the position of the barrel in the bipod rings, press the handle down against the bipod rear ring.

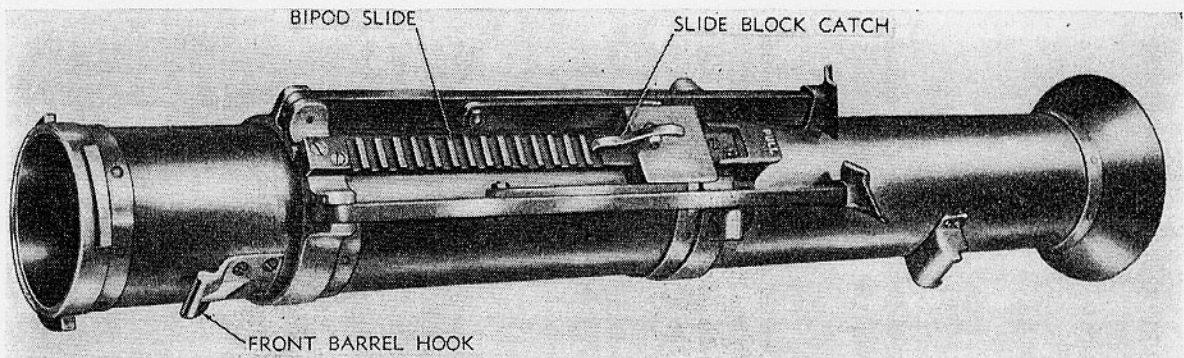

3.5-INCH ROCKET LAUNCHER M20 (OF EARLY MANUFACTURE)

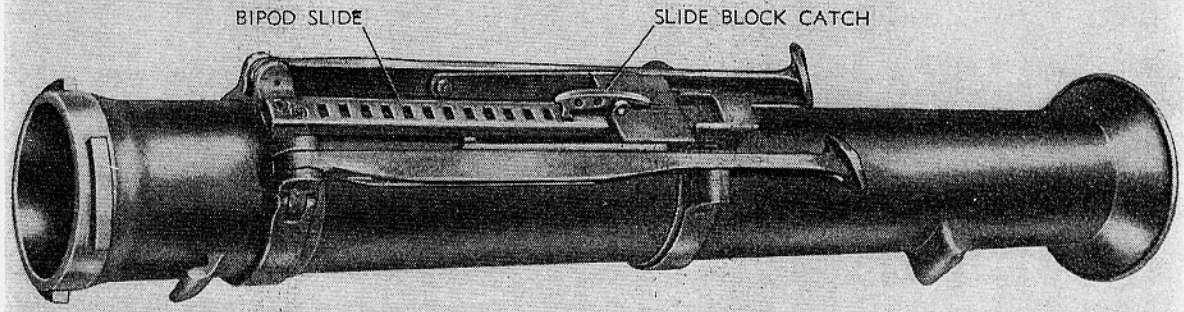

3.5-INCH ROCKET LAUNCHER M20B1

RA PD 118080

Figure 8. Front barrel bipod folded.

c. The rear ring lock handle releases the rear ring lock so that the front barrel can be rotated in the bipod rings. When the weapon stands on its bipod and monopod, uneven ground may tilt the bipod and to prevent tilt of the bipod from affecting the sighting of the weapon the rear ring lock is released and the barrel rotated in the bipod rings to bring the monopod exactly vertical as gaged by eye. The bipod rear ring is located in this position. Stops on the barrel prevent longitudinal motion of the barrel in the bipod rings when the lock is released (par. 21*b* (2)).

19. Contactor Latch Housing Assembly

a. The contactor latch clamp encircles the rear barrel of M20 launchers just forward of the breech guard. The contractor latch housing assembly of M20 launchers pivots on this clamp. The contactor latch housing assembly of M20B1 launchers pivots on lugs cast integral with the rear barrel. The contactor latch plate protrudes through an opening in the breech guard (fig. 28). Except for the brass shunt, the contactor latch housing assembly is made of steel.

b. A steel blade, riveted to the rear of the body of the contactor latch housing assembly, engages notches in the radial fins at the rear of the rocket and serves to hold the rocket in its proper firing position in the launcher. The contact between the blade of the contactor latch and the rocket fins provides grounding of the rocket to the rear barrel for the completion of the firing circuit. A spring keeps the rear end of the contactor latch housing assembly depressed.

c. When the forward end of the contactor latch housing assembly is pressed down against the barrel, the blade at the rear of the housing assembly swings clear of the breech of the launcher tube. This is done during loading or unloading of the launcher (pars. 21*c* (5) and 23).

20. Sighting Equipment

The sighting equipment of M20 launchers is supported on a bracket which appears on the left side of the rear barrel just forward of the monopod. The reflecting sight assembly pivots in a bushing of the sight bracket assembly. An elevation plate is mounted on the sight bracket (sec. IX, ch. 3). The support of the sighting equipment of M20B1 launchers is similarly located but is cast integral with the rear barrel.

a. RANGE SCALE.

- (1) The range scale is on the elevation plate and each weapon is equipped with either one of two elevation plates. The elevation plate must correspond to the reticle of the reflecting sight assembly used. Weapons equipped with reflecting

sight assemblies D7313440 (concentric circle-fig. 37) or D7162890 (oval-fig. 38) use elevation plate C7138366 (fig. 35). Weapons equipped with reflecting sight assembly D7141999 (ladder type reticle-fig. 39) use elevation plate C7141998 (fig. 34).

- (2) The range scale on elevation plate C7138366 (fig. 35) is calibrated from 0 to 9 and indicates the range in hundreds of yards. A notch on the elevation plate for each fifty yards of range is engaged by a projection on the indicator arm pointer as it sweeps over the elevation plate when the indicator arm and reflecting sight are swung on the pivot in the sight support. These notches serve as detents to hold the range setting of the sight.
- (3) The range scale on elevation plate C7141998 (fig. 34) is calibrated from 0 to 9 but there are no calibrations between 0 and 5. The figures on the elevation plate indicate the range in hundreds of yards. Calibrations are not needed between 0 and 5 on the elevation plate because a range up to 450 yards is covered by the reticle pattern. Between 5 and 9 on the range scale there is a notch on the elevation plate for each 50 yards of range. These notches are engaged by a projection on the indicator arm pointer as it sweeps over the elevation plate when the indicator arm and reflecting sight are swung on the pivot in the sight support. These notches serve as detents to hold the range setting of the sight.
- (4) To set the sight to a specific range, move the indicator arm to the position on the elevation plate corresponding to the desired range. For example: If the range is estimated as 600 yards, set the indicator arm pointer at "6" on the elevation plate.

b. GRADUATIONS ON INDICATOR ARM YOKE. The reflecting sight lens frame is secured to the indicating arm yoke by a hinge stud which permits the sight to be folded back out of the way against the launcher rear barrel when not in use (figs. 34 and 35) or to be swung out into the extended position (fig. 36) for use in firing. The head of the hinge stud carries an index mark which is set against the adjacent scale on the indicator arm yoke when setting the sight in azimuth during boresighting (par. 56*b*). The five graduations on the indicator arm yoke, spaced 15° apart, are for reference only.

c. MANIPULATION OF SIGHT.

- (1) The sight is unfolded from its carrying position by pulling it out away from the barrel, causing it to pivot on the sight hinge stud in the yoke of the indicator arm. It is swung out until the ball detent of the sight hinge stud engages and holds the sight in its firing (sighting) position.

- (2) The detent functions to hold the sight in both its carrying and firing (sighting) positions.
- (3) After use, the sight is swung back out of the way (for carrying) by pushing it back against the barrel until the detent snaps and secures the sight in carrying position.

Section IV. OPERATION UNDER USUAL CONDITIONS

21. Preparing Launcher for Firing

a. ASSEMBLING.

- (1) Release the barrel latch (par. 14) and disengage the barrels (fig. 9).
- (2) Raise the barrel coupling lock lever and hold it in its unlocked position (par. 13). Screw the front barrel into the coupling nut of the rear barrel (fig. 10). Release the lock lever.
- (3) When these directions have been followed, the launcher is ready for loading while held in the standing, kneeling, or sitting positions. The launcher also may be fired from the prone position, in which case it is stood upon the bipod and monopod.
- (4) Prepare the ammunition for firing as described in paragraph 65.

b. PREPARING TO FIRE FROM PRONE POSITION. To prepare the launcher for firing from the prone position it is first assembled as described in *a* above.

- (1) *Unfold the bipod.* Pull the bipod trip (par. 16) and lower the bipod to its unfolded position. Stand the launcher on its bipod and monopod.
- (2) *Level the sight.* If uneven ground tilts the bipod, level the sight by releasing the bipod rear ring lock. Swing the monopod to an exactly vertical position as gaged by eye. Lock the bipod rear ring (par. 18) to improve stability.
- (3) *Elevate the launcher.* Adjust the elevation of the launcher as required by rotating the monopod sleeve body (par. 15). This is done while sighting on the target (*d* below).

Caution: In assuming the prone position, the gunner must lie at an angle of not less than 45° to the line of aim to avoid injury by the rear blast of the weapon. The gunner must take care that movement of the weapon in tracking the target does not inadvertently place his feet within the danger zone behind the launcher (par. 22).

c. LOADING.

- (1) Prior to loading make sure that the bore is clean.
- (2) Put the safety in its "SAFE" position (par. 12).

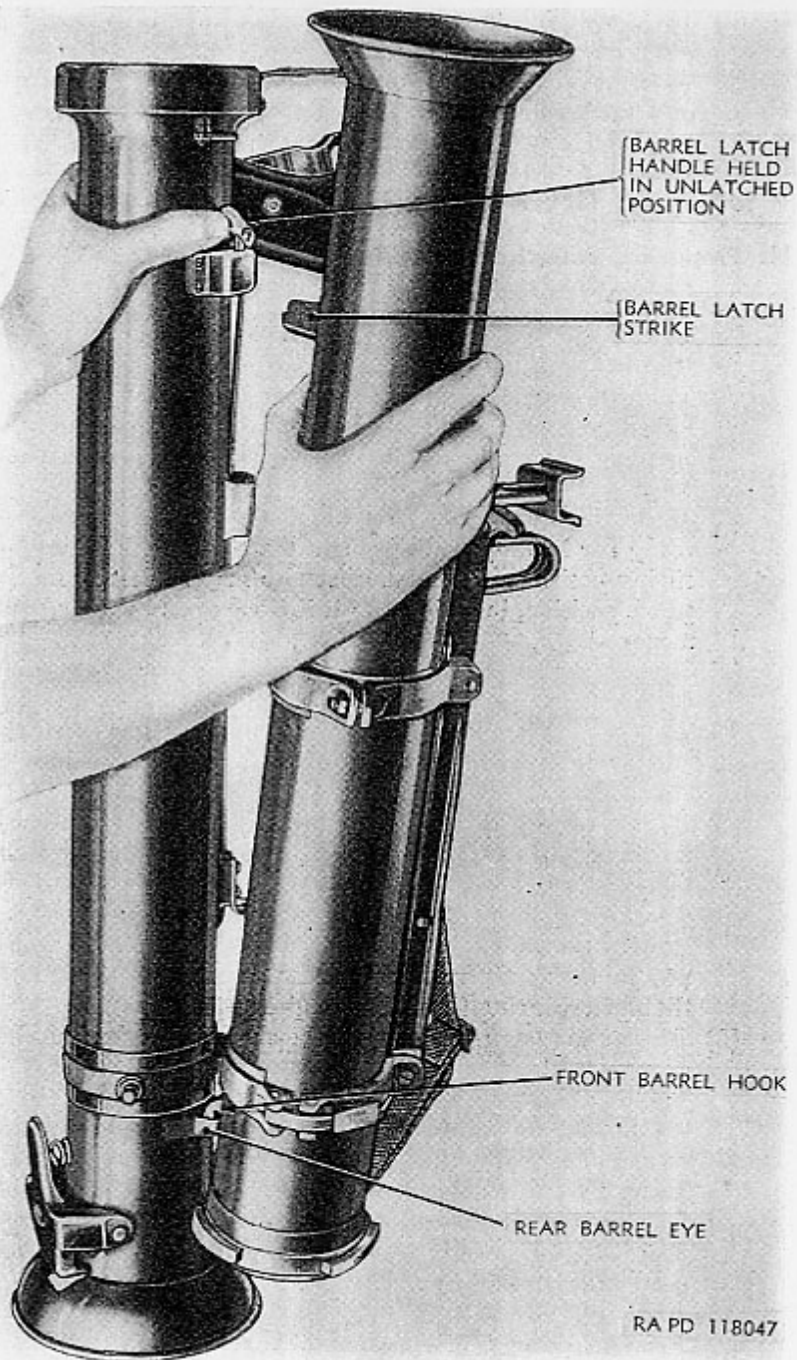

RA PD 118047

Figure 9. Unlatching the barrels from carrying position.

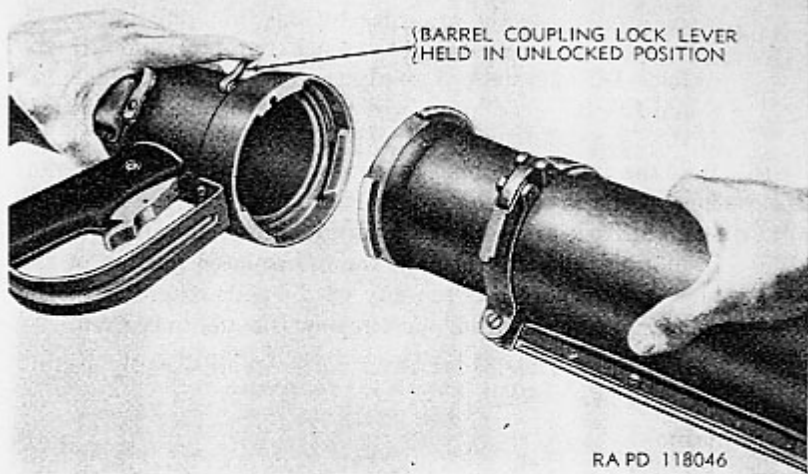

Figure 10. Joining the barrels.

- (3) If the launcher is to be fired from the sitting, kneeling, or standing position, the gunner places it on his right shoulder. As described in *b* above, the launcher is stored on its bipod and monopod in preparation for firing from the prone position.
- (4) Remove the shorting clip (fig. 42) from the contact ring assembly of the rocket before loading the rocket into the launcher (par. 65).
- (5) Grasp the rocket by the motor tube and insert the head into the rear of the launcher barrel, at the same time depressing the front end of the contactor latch housing assembly (par. 19) to clear the way for the rocket.
- (6) Having inserted the head of the rocket into the launcher barrel, hold the rocket in this position and remove the safety band from the rocket.
- (7) Again depress the front of the contactor latch and carefully push the rocket into the launcher barrel until the contactor latch blade engages a continuous groove in the support band for the radial fins of the rocket (par. 19*b*).

Caution: Do not jar a loaded launcher. After a rocket has been loaded into a launcher, the ejection pin of the fuze is held depressed and the rocket therefore is prepared for arming. Jarring the launcher would unlatch the rocket and cause it to slip out of the barrel. If a loaded launcher is dropped so that the breech guard strikes the ground first, the shock may move the setback sleeve of the rocket fuze suffi-

ciently to lock it in its rearward position. If the rocket has been thrown into the launcher by the fall, pull it back to firing position (do not pull it back too far) and fire the rocket. Dislodgement of an armed rocket from the launcher would free the ejection pin which would then be thrown clear of the fuze. Refer to paragraph 23f; note the warning.

- (8) Pull the end of the blue contact wire out of the expansion cone at the rear of the rocket (fig. 42). Pull the blue wire straight back to uncoil it. Straighten the end and pull the insulating tube off. Engage the uninsulated portion of the blue contact wire between any of the coils of either of the constant springs. The launcher now is ready to be fired.

Warning: The loader never must stand directly behind the launcher.

d. SIGHTING.

- (1) *Preparing sight for use.* Open the lens cover and snap the sight into firing (sighting) position.
- (2) *Reflecting sight assemblies D7313440 and D7162890 (concentric ring and oval reticle patterns)* (figs. 37 and 38).
 - (a) Estimate the range in yards to the target and set the indicator arm on the corresponding position on the elevation plate (par. 20).
 - (b) Sight through the reflecting sight and adjust the elevation of the launcher so that the horizontal line of the reticle is on the target.
 - (c) Estimate the speed of the target in miles per hour to determine the lead necessary and position the target in the proper ring (par. 54e (1)) or in the proper scribed or indicated oval (par. 54e (2)) of the sight reticle.
- (3) *Reflecting sight assembly D7141999 (ladder type reticle pattern)* (fig. 39).
 - (a) Estimate the range in yards to the target and if the estimated range is less than 500 yards, set the indicator arm in its zero (0-450) position on the elevation plate (par. 20).
 1. Sight through the reflecting sight and adjust the elevation of the launcher so as to bring the dashed horizontal range line of the reticle, which corresponds with the estimated range, on the target. (For example: if the estimated range is 300 yards, place the target on the horizontal reticle range line marked "300"; if the estimated range is 350 yards, horizontally aline the target with the bottom of the sector of the vertical center line on the reticle just below the "300" range line.)

2. Estimate the speed of the target in miles per hour to determine the lead necessary and position the target on the proper sector of the range line.
- (b) If the estimated range is 500 yards or more, set the indicator arm on the corresponding position on the elevation plate (par. 20).
1. Sight through the reflecting sight and adjust the elevation of the launcher so as to bring the normal line of the reticle (the dashed horizontal line marked "0") on the target (fig. 39).
 2. Estimate the speed of the target in miles per hour to determine the lead necessary and position the target on the proper sector of the normal line of the reticle (par. 54e).

22. Firing

a. To fire the rocket, move the safety to the "FIRE" position and squeeze the trigger (par. 12). If the rocket fails to fire, make several attempts (par. 24) but be sure to keep the launcher on the target while attempting to fire it. *Whenever firing is not being attempted, the safety must be kept in its "SAFE" position.*

Note.—Some M20 launchers are equipped with electric firing mechanism C7313326 (single action—fig. 7). If the rocket does not fire when the trigger is squeezed, it may fire when the trigger is released. When firing one of these launchers, squeeze the trigger and release it immediately: do not move the launcher off the target before releasing the trigger. This instruction does not apply to M20B1 launchers or M20 launchers equipped with electric firing mechanism B7140325 (double action—fig. 7).

Caution: Before firing the launcher, it must be determined that the area behind the launcher within a distance of 25 yards is clear of personnel or inflammable material. The danger zone is designated as a triangle area with a base and height of 25 yards, the apex of the triangle being at the breech of the launcher and its height an extension of the launcher axis. The height of the triangle bisects the base (fig. 11).

b. Care will be exercised when firing through brush and trees since impact with a twig or branch may deflect the rocket. A heavy branch may detonate the rocket.

23. Unloading

a. Before unloading the launcher, move the safety to the "SAFE" position (par. 12).

b. If a misfire has occurred, perform the immediate action described in paragraph 24. Wait at least 15 seconds.

c. Remove the rocket contact wire from the contact spring of the launcher, depress the forward end of the contactor latch housing assembly and carefully withdraw the rocket just sufficiently to expose the ejection pin of the rocket. If the ejection pin tends to bear against the breech guard of the launcher, press it back and hold it. Install the safety band over the ejection pin (par. 65).

d. Again depress the forward end of the contactor latch housing assembly to clear the rocket head, and completely remove the rocket from the launcher.

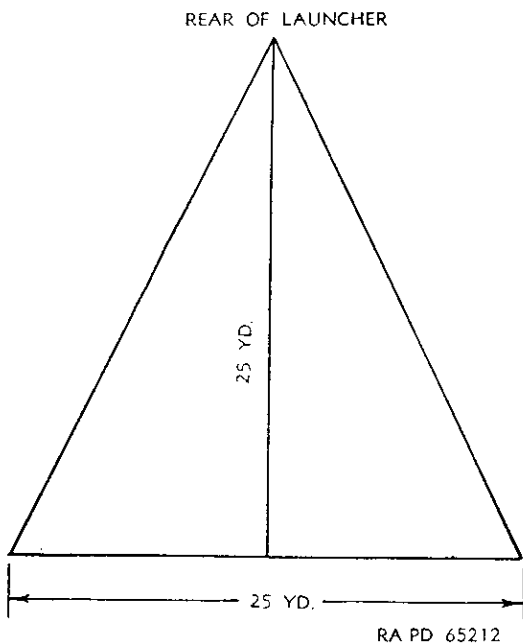

Figure 11. Danger zone to rear of 3.5-inch rocket launcher.

e. Coil the blue contact wire and place it inside the expansion cone at the rear of the rocket. Repack the rocket in its fiber container.

f. If the ejection pin should be prematurely ejected, replace the ejection pin if this can be done without forcing. Install the safety band over it. The rocket then is safe to handle.

Warning: Without the ejection pin in place, the rocket is armed and must be handled nose up, with extreme care. If the ejection pin cannot be replaced, the rocket must be destroyed as soon as practicable in accordance with TM 9-1900.

24. Immediate Action To Correct a Misfire

a. DEFINITION. The procedure prescribed for clearing a rocket launcher for further use when a misfire occurs during actual or simulated combat firing is termed "Immediate Action."

b. MISFIRE. When a misfire occurs, perform the immediate action described below.

- (1) If the misfiring weapon is an M20 launcher equipped with electric firing mechanism C7313326 (single action—fig. 7), check to make sure that the safety switch is in the "FIRE" position. This instruction does not apply to M20B1 launchers or to M20 launchers equipped with electric firing mechanism B7140325 (double action—fig. 7) because the trigger of this mechanism cannot be squeezed with the safety in its "SAFE" position.
- (2) Attempt to fire the rocket again by squeezing the trigger while keeping the launcher sighted on the target.
- (3) If the rocket still does not fire, make certain that the uninsulated end of the blue contact wire of the rocket engages the contact spring of the launcher, that the contactor latch blade is engaged in the fin notches of the rocket, and that the blade and notches are clean. Sight the launcher on the target and again squeeze the trigger.
- (4) If the rocket still does not fire, remove the rocket from the launcher as outlined in paragraph 23. After the rocket is removed, repack it and put it aside for disposal by authorized personnel.

25. Preparation for Carrying

a. Hold the barrel coupling lock lever in the unlocked position and unscrew the front barrel from the rear barrel. Release the lock lever.

b. Engage the barrel hook and eye and press the barrels together (fig. 9) until the barrel latch snaps into position in the latch strike (par. 14). If necessary release the bipod rear ring lock, rotate the bipod assembly to avoid interference and close the bipod rear ring lock (par. 18).

Section V. OPERATION UNDER UNUSUAL CONDITIONS

26. General

a. The mechanical steps of operation under unusual atmospheric conditions are the same as for operation under usual (moderate) atmospheric conditions which are covered in section IV of chapter 2. The only difference in procedure is in the servicing of the launcher

with regard to cleaning and lubrication, to insure proper functioning in locations where the atmosphere is salty or where extremes in temperature and humidity of the atmosphere occur. Special care will be observed with regard to cleaning and lubrication of the launcher as explained below. Such care is necessary to insure proper operation and functioning of the weapon and to guard against excessive wear of the moving parts. Proper care prevents deterioration of the matériel.

b. Under any conditions, the bore of the barrels and the contactor latch must be wiped thoroughly free of excess oil before firing the launcher.

c. See paragraph 64*c* (2) for temperature limitations of the firing of the rockets.

27. Arctic Climates

In temperatures below freezing, and particularly in Arctic climates, all operating parts should be kept absolutely free of moisture. Immediately upon being brought indoors, the launcher will be cleaned on the outside and inside with a dry clean cloth. Remove the trigger grips. Clean, dry, and oil the firing mechanism (par. 35*d* and *e*). After it has reached room temperature, again clean, dry, and oil the launcher.

28. Tropical Climates

In tropical climates where temperature and humidity are high or where salt air is present, and during rainy seasons, the launcher will be thoroughly inspected and cleaned daily. In humid, salty atmosphere, oil the bore and all unpainted metal surfaces whether steel or aluminum as prescribed in LO 9-297 (fig. 12) every day.

29. Hot Dry Climates

In hot dry climates where sand and dust are apt to get into the bore, the launcher including the bore will be wiped clean daily or more often if necessary. During sand or dust storms the launcher will be kept covered.

CHAPTER 3

MAINTENANCE INSTRUCTIONS

Section I. GENERAL

30. Scope

This chapter contains information for the guidance of the personnel of the using organizations responsible for the organizational maintenance of this equipment, as well as for ordnance maintenance personnel. It contains information needed for the performance of the scheduled lubrication and preventive maintenance services, as well as a description of the major systems and units and their functions in relation to other components of the matériel.

31. Cleaning and Preserving Materials

The following cleaners and preservatives are required for use with this matériel. See TM 9-850 for information additional to that contained in this manual on the use of these materials. Refer to Department of the Army Supply Catalog ORD 3 SNL K-1, which is the authority for requisitioning these items.

Cleaner, rifle bore.

Cloth, crocus, sheets, 9 by 11 inches.

Cloth, wiping, cotton.

Enamel, synthetic, olive-drab, lusterless.

Oil, lubricating, preservative.

Section II. PARTS, SPECIAL TOOLS, AND EQUIPMENT FOR ORGANIZATIONAL MAINTENANCE

32. General

No spare parts or tools are issued to the using organization for maintaining the matériel.

33. Equipment

Equipment supplied with the Launcher, rocket, 3.5-inch, M20 and M20B1 is listed in Department of the Army Supply Catalog ORD 7 SNL B-42, which is the authority for requisitioning replacements. The gun sling M1 (webbing), identifying number 6544058, is the only item of equipment required for use with the launchers M20 or M20B1 (figs. 18 and 20).

Section III. LUBRICATION

34. General Lubrication Instructions

a. Lubrication will be accomplished carefully and sparingly. Excess oil will be wiped off.

b. Excess oil attracts grit and foreign matter which will cause rapid wear of the moving parts.

c. Unless otherwise specified, use rifle bore cleaner or dry-cleaning solvent to clean or wash all metal parts, whenever partial or total disassembly is undertaken, or when removing the protective film of preservative lubricating oil on exposed steel surfaces. Gasoline will not be used. Dry all parts thoroughly before lubricating.

Note.—Thinner, paint, volatile mineral spirits, may be substituted for solvent dry cleaning, wherever the latter is specified.

35. Points To Be Cleaned and Lubricated

Under normal conditions all bearing surfaces of moving parts will be lightly lubricated. This is best accomplished with a clean, lintless cloth saturated in the proper lubricant, wrung out, and then wiped over the surface to be lubricated.

a. BORE. Clean and oil as prescribed in lubrication order LO 9-297 (fig. 12) and indicated in paragraph 41*a*. The cleaning and oiling immediately after firing and for three consecutive days thereafter which is specified in the lubrication order is accomplished as follows:

- (1) Wet a wiping cloth with rifle bore cleaner and run it through the bore several times. Then run a dry wiping cloth through the bore.
- (2) Repeat these operations until the bore is clean and apply a film of rifle bore cleaner to the bore.
- (3) For the three consecutive days after firing, clean and oil the bore as described above; except that on the fourth cleaning after firing, thoroughly dry the bore after cleaning and oil as prescribed in LO 9-297 (fig. 12).

b. CONTACTOR LATCH PINS. At intervals specified in paragraph 41*a*, apply one or two drops of preservative lubricating oil to the contactor latch pins.

c. CONTACTOR LATCH. Clean at intervals specified in paragraph 41*a*. Remove any powder fouling or rust with rifle bore cleaner or dry-cleaning solvent. Crocus cloth may be used to remove deep seated corrosion. Wipe dry and protect with film of lubricant (LO 9-297, fig. 12). Wipe thoroughly dry before firing.

LUBRICATION ORDER LO 9-297(Supersedes LO 9-297
21 Feb. 1949)**LAUNCHER, ROCKET, 3.5 - INCH, M20 & M20 B1**

References TM 9-297, ORD 7 SNL B-42

BORE—After firing and on 3 consecutive days thereafter, clean with CR. After 4th cleaning, dry, oil with PL Medium above +32°F, PL Special below +32°F. Wipe clean before firing. When weapon is not being fired, renew oil film weekly. In humid and salt air areas, use PL Medium.

FIRING MECHANISM, (C7313326) BARREL COUPLING LOCK, BIPOD LEG LOCK BUTTONS, BIPOD SLIDE, BIPOD REAR RING LOCK, CONTACTOR LATCH, AND MONOPOD—Weekly and after firing, oil with PL Medium above +32°F, PL Special below +32°F. In humid and salt air areas, use PL Medium.

LUBRICATED BY HIGHER ECHELON—Firing Mechanism (C7313326) (B7140325): Monthly, remove grips. Coat entire mechanism with PL Medium above +32°F, PL Special below +32°F. In humid and salt air areas, use PL Medium.

PL—OIL, lubricating, preservative

CR—CLEANER, rifle bore

This LO supersedes all conflicting lubrication instructions dated prior to the date of this Lubrication Order.

BY ORDER OF THE SECRETARY OF THE ARMY:

J. LAWTON COLLINS

Chief of Staff, United States Army

OFFICIAL:

EDWARD F. WITSELL, Major General, USA
The Adjutant General

RA PD 118744

Figure 12. LO 9-297.

d. **FIRING MECHANISM C7313326 (SINGLE ACTION—FIG. 7).**

- (1) For the weekly lubrication prescribed in lubrication order LO 9-297 (fig. 12) and indicated in paragraph 41*a*, no disassembly is required. Lift the trigger spring washer toward the trigger to expose the opening in the rocker arm cover for the toggle pin. Inject approximately 10 drops of oil into this opening.
- (2) For the monthly lubrication prescribed in lubrication order LO 9-297 (fig. 12) and indicated in paragraph 41*a*, it is necessary to remove the grips (par. 48*a*). Clean the parts of any dirt and corrosion. Apply a film of oil to all metal parts of the firing mechanism.

Note.—Corrosion on the armature will be disregarded.

e. **FIRING MECHANISM B7140325 (DOUBLE ACTION—FIG. 7).** Monthly or more frequently when operating in sandy, dusty, humid, or salt air areas or whenever the weapon is exposed to wet weather, or exceptionally hard usage remove the grips (par. 48*b*) and lubricate as prescribed in lubrication order LO 9-297 (fig. 12).

- (1) Wipe all parts clean.
- (2) Apply the prescribed lubricant to the trigger at the pin and to the slot in the back of the trigger above and below the trigger latch. Operate the firing mechanism several times after applying lubricant to the trigger latch.

LIFT TRIGGER
 SPRING WASHER
 TOWARD THE
 TRIGGER TO
 EXPOSE OPENING

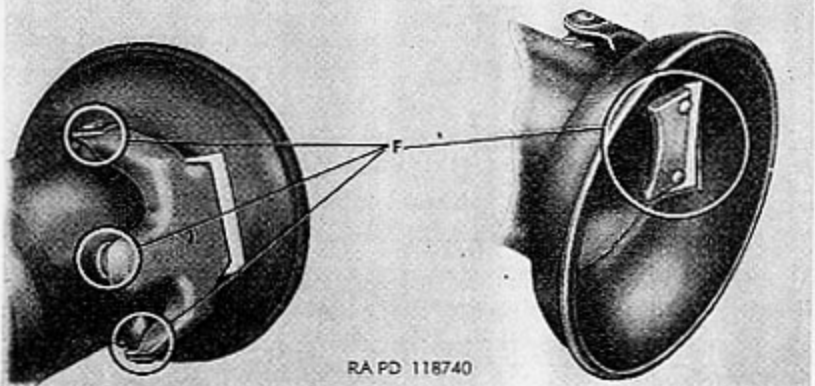
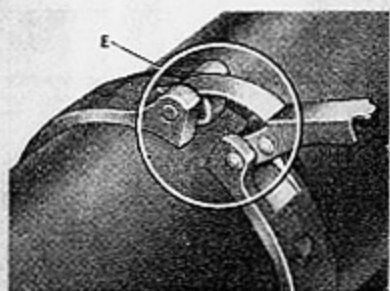
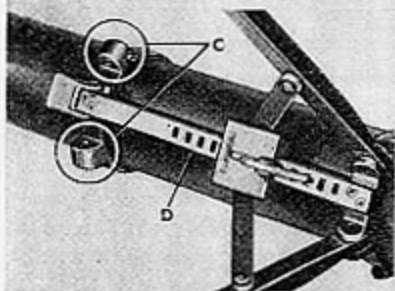
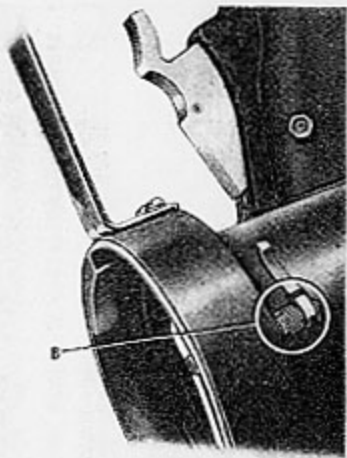
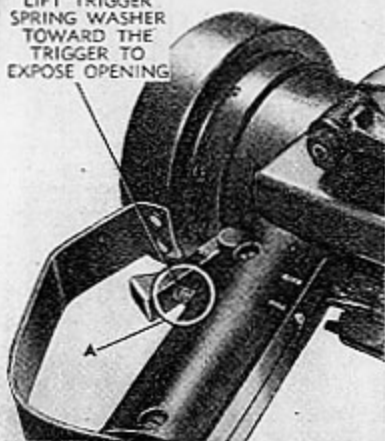

RA PD 118740

- A. Firing mechanism C731336.
 B. Barrel coupling lock.
 C. Bipod leg lock buttons.

- D. Bipod slide.
 E. Bipod rear ring lock.
 F. Contactor latch.

Figure 13. Localized lubrication points, A through F.

- (3) Apply prescribed lubricant to the roller on the trigger latch, to the trigger bar, especially to both pins in the trigger bar, and to the armature spring sleeve.
- (4) Place the blade of a screwdriver against the front of the top plate of the firing mechanism so as to stop the safety lugs of the trigger about $\frac{1}{8}$ inch from the top plate when

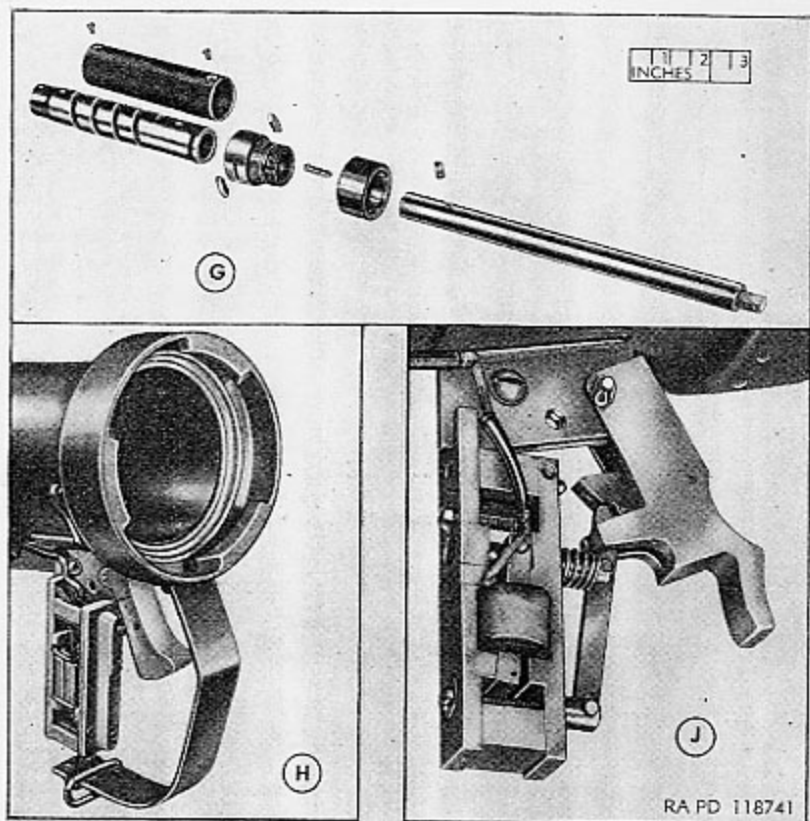

G. Monopod.

H. Firing mechanism C7313326.

J. Firing mechanism B7140325.

Figure 14. Localized lubrication points, G through J.

the trigger is squeezed (fig. 15). Hold the trigger lugs against the screwdriver. This holds the top of the armature in its rearward position and exposes the slot in the armature spring sleeve and a little of the armature spring. Apply the prescribed oil to the opening in the sleeve. Again manipulate the trigger a few times to work the oil into the sleeve.

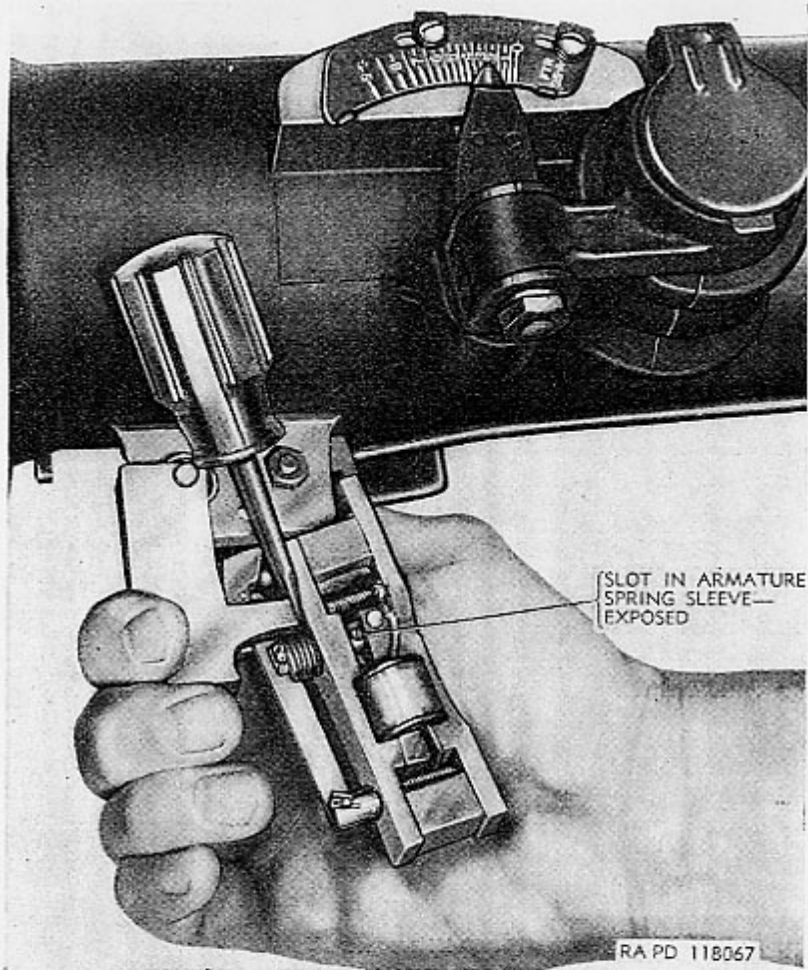

Figure 15. Oiling armature spring of firing mechanism B7149325 (double action).

(5) Wipe off excess oil and assemble the grips to the firing mechanism (par. 48b (3)).

f. BIPOD SLIDE. Clean the slide at intervals specified in paragraph 41a. If corrosion has occurred and rifle bore cleaner or dry-cleaning solvent will not clean the slide properly, remove the rust spots with crocus cloth. Wipe thoroughly dry and apply a film of lubricant (LO 9-297, fig. 12).

g. BARREL LATCH. At intervals specified in paragraph 41a, clean and lubricate the barrel latch. Remove barrel latch bolt (par. 45g (1)). Clean all parts with rifle bore cleaner or dry-cleaning solvent.

Wipe dry and apply light film of lubricant (LO 9-297, fig. 12). Assemble.

h. BARREL COUPLING LOCK. At intervals specified in paragraph 41*a*, clean and lubricate the barrel coupling lock. For the monthly maintenance it will be necessary to disassemble the barrel coupling lock (par. 45*f* (1)). Clean all parts with rifle bore cleaner or dry-cleaning solvent. Wipe dry and apply light film of lubricant (LO 9-297, fig. 12). Assemble.

i. BIPOD REAR RING LOCK. At intervals specified in paragraph 41*a*, clean and lubricate the bipod rear ring lock. For the monthly lubrication of the continuous ring type (fig. 23), it will be necessary to disassemble the bipod rear ring lock (par. 45*e* (1)). Clean all parts with rifle bore cleaner or dry-cleaning solvent. Wipe dry and apply light film of lubricant (LO 9-297, fig. 12). The split ring type of bipod rear ring lock (fig. 24) is not to be disassembled for lubrication by the using arm.

j. MONOPOD. At intervals prescribed in lubrication order LO 9-297, figure 12, and indicated in paragraph 41*b*, lubricate the monopod.

- (1) The monopod must be disassembled (par. 51*a*) to obtain access to the parts requiring lubrication.
- (2) Clean all parts with rifle bore cleaner and wipe dry. Apply film of lubricant to all parts, excluding painted external surfaces.
- (3) Reassemble the monopod (par. 51*b*).

Section IV. PREVENTIVE MAINTENANCE SERVICE

36. General

Preventive maintenance services prescribed by Army Regulations are a function of organizational maintenance units, and their performance is the responsibility of the commanders of such units. These services consist generally of before-firing, during-firing, after-firing, and scheduled services to be performed at designated intervals by organizational maintenance personnel. A schedule of services to be performed by ordnance maintenance personnel also is included. This section contains general preventive maintenance procedure and specific maintenance procedure applying to the launcher.

37. Operational Inspection

a. Inspect the launcher for general condition, loose or broken components, painting defects, bends and dents, or for obstructions in the bore (par. 9).

b. Check the functioning of the barrel coupling lock. When the barrels are coupled in any of the three locked positions, the front barrel must be locked firmly in the rear barrel without play.

c. Check functioning of the monopod. The operation of the monopod in extending and retracting the monopod leg should be smooth. The monopod leg and foot must resist turning.

d. Check for any broken or loose wire connections.

e. Check for corroded electric contact points.

f. Examine the contact springs to see that they are secure to the clamp and that they are clean and free from rust, paint, and grease.

38. Cleaning and Retouching

a. **PRIOR TO FIRING.** Run a clean dry wiping cloth through the barrels. Any oil in the bore must be wiped dry.

b. **EXTERNAL PARTS.** Chipped or exposed metal surfaces will be cleaned and repainted with lusterless, olive-drab, synthetic enamel (par. 46*h*). *Do not paint contact springs, contact surfaces of the contactor latch, or the sight.*

c. **AFTER USE IN WET WEATHER.** Remove the grips (par. 48*a* (1) and *b* (1)). Clean, dry, and oil the firing mechanism (par. 35*d* and *e*).

39. Basic Preventive Maintenance

The following general preventive maintenance will be observed in addition to that referred to in paragraph 41.

a. Dirt, grit, gummed oil, and water cause rapid deterioration of internal mechanisms and outer unpainted steel surfaces. (The bipod slide, many firing mechanism parts, and many of the controls are made of steel. Par. 46*i* lists the steel parts of the barrel assemblies.)

b. Powder fouling attracts moisture and hastens the formation of rust. If rust should accumulate, it must be removed immediately. Crocus cloth will be used for this purpose. The use of coarse abrasives is strictly forbidden.

c. Avoid getting dry-cleaning solvent, rifle bore cleaner, or any petroleum cleaning fluid on the rubber eyeshield or on the reflecting sight lens. Wash rubber eyeshield with soap solution (1 ounce of soap chips to a quart of water) or with water alone. See paragraph 55*b* for lens cleaning directions.

d. Check the operation of all controls for functioning (sec. III, ch. 2). Tighten loose parts and replace broken parts.

40. Repairs

The following operations will be performed by ordnance maintenance personnel only:

- a. Check serviceability of the firing mechanism with the firing mechanism electrical output tester (par. 73).
- b. Replace defective firing mechanism (par. 48a (2) and b (3)).
- c. Solder all loose or broken soldered connections.
- d. Remove bipod for cleaning.

41. Preventive Maintenance Schedules

a. ORGANIZATIONAL

DAILY

<i>Point</i>	<i>Preventive maintenance</i>	<i>Detailed instructions</i>
Barrel.....	Examine for dents.	Par. 37a.
Contact springs.....	Examine to see that they are secure to the clamp, clean, and free from rust, paint, and grease.	Par. 37f.

BEFORE FIRING

Barrel.....	Wipe clean.....	Par. 35a LO (fig. 12).
Wiring and connections...	Check for loose connections and condition of wiring.	Par. 37d.
Sight.....	Check for loose or broken lenses.	
Contactors latch.....	Clean, wipe dry.....	Par. 35c LO (fig. 12).
Contact springs.....	Check for corrosion, paint, grease, or dirt. Clean.	Par. 37f.
Barrel coupling screw.....	Check for erosion and burs.	Par. 46a.
Barrel coupling nut.....	Check for erosion and burs.	Par. 46a.
Barrel coupling lock.....	Test functioning. Check for rust and burs.	Par. 13 and 46a.
Bipod trip.....	Test functioning.....	Par. 16.
Bipod slide and slide block catch.	Test functioning. Check for rust and burs.	Par. 17 and 46e.
Bipod leg lock buttons...	Test functioning. Check for rust.	Par. 16.

AFTER FIRING

Barrel.....	Clean.....	Par. 35a LO (fig. 12).
Contactors latch.....	Clean.....	Par. 35c.
All parts.....	Record any malfunctions or damages resulting from firing and correct before next firing.	

WEEKLY

<i>Point</i>	<i>Preventive maintenance</i>	<i>Detailed instructions</i>
Contact springs	Clean	
Barrel	Clean with rifle bore cleaner, wipe dry, and oil.	
Barrel coupling lock	Oil	Par. 35 <i>h</i> LO (fig. 12).
Contacting latch pins	Oil	Par. 35 <i>b</i> LO (fig. 12).
Contacting latch	Clean and oil	Par. 35 <i>c</i> .
Firing mechanism	Oil	Par. 35 <i>d</i> and <i>e</i> LO (fig. 12).
Bipod leg lock buttons	Oil	
Bipod slide	Clean and oil	Par. 35 <i>f</i> LO (fig. 12).
Bipod rear ring lock	Clean and oil	Par. 35 <i>i</i> LO (fig. 12).
Wiring and connections ..	Check for loose connections and condition of wiring.	

MONTHLY

Insulating band for contact spring clamp.	Inspect for damage	Pars. 43 <i>d</i> and 45 <i>j</i> .
Barrel coupling lock	Clean and oil	Par. 35 <i>h</i> .
Barrel latch	Clean and oil	Par. 35 <i>g</i> .
Bipod rear ring lock	Clean and oil	Par. 35 <i>i</i> .
Contacting latch shunt	Check firmness of fastening.	Par. 43 <i>e</i> .
Firing mechanism	Remove grips. Clean and oil.	Par. 35 <i>d</i> and <i>e</i> LO (fig. 12).
All parts	Thoroughly inspect and repair if necessary.	

b. ORDNANCE MAINTENANCE PERSONNEL

MONTHLY

<i>Point</i>	<i>Preventive maintenance</i>	<i>Detailed instructions</i>
Monopod	Disassemble, clean, and lubricate.	Pars. 51 <i>a</i> and 35 <i>j</i> LO (fig. 12).

SEMIANNUALLY

Firing mechanism	Check with firing mechanism electrical output tester.	Pars. 71, 72, and 73.
------------------------	---	-----------------------

Section V. TROUBLE SHOOTING

42. General

Proper care of the launcher before, during, and after firing will eliminate most malfunctions. Malfunctions which cannot be remedied by immediate action (par. 24) will be dealt with in accordance with the instructions in paragraph 43.

43. Failure To Fire

Failure to fire generally is caused either by defective ammunition or defective firing mechanism.

a. If the contact wire is loosely connected to the rocket, the rocket is defective and will be turned over to ordnance maintenance personnel.

b. Defective firing mechanism may be due to spent magnets, loose connections, or broken parts.

c. Remove the trigger grips (par. 48*a* (1) and *b* (1) and check firing mechanism for loose joints or contacts and for breakage. If any part of the firing mechanism is worn or broken, notify ordnance maintenance personnel.

d. Inspect the wiring. Look especially for damaged insulation. Be sure that the contact spring clamp is positioned properly on the insulating band and that the insulating band is not damaged. Be sure that the insulating sleeve on the end of the aluminum tube of the contact lead wire completely separates the contact spring clamp from the aluminum tube and that the insulating sleeve is not damaged (par. 45*j*).

e. Inspect the contactor latch. Be sure that both ends of the shunt of the contactor latch are fastened securely (par. 45*h*) to insure good grounding of the latch. Blade at rear of contactor latch body must be clean and free of oil film. Contactor latch spring must press blade against rocket. Replace defective spring (par. 45*h*). Contact surfaces of notches in radial fins of rocket must be clean.

f. Inspect contact springs. They must be clean and free of corrosion. The contact springs must firmly clamp the bare end of the rocket blue contact wire. The bare end of the rocket blue contact wire must be clean.

Section VI. FRONT AND REAR BARREL GROUP

44. General

a. The front and rear barrels are joined by means of the barrel coupling screw on the rear end of the front barrel and the barrel coupling nut on the forward end of the rear barrel. The barrel coupling screw and nut and both barrels are made of aluminum. On the M20B1 launcher, these parts are cast integral with the barrels. The coupling screw and nut contain a single-thread interrupted screw, so arranged that only about 60° clockwise rotation completely engages the front barrel in the rear barrel. A stop prevents further clockwise rotation. A barrel coupling lock locks the barrel joint. A spring holds the coupling lock in its locked position (par. 13*b*). For ease in carrying, the barrels are uncoupled and secured to each other, side by side, by means

of the barrel hook and eye and the spring actuated barrel latch and strike (par. 25). A muzzle deflector on the front barrel (fig. 17) at the muzzle end serves to divert particles of unburned powder which otherwise might strike the gunner's face.

b. The front barrel is free to rotate in the bipod when the bipod rear ring lock is released (par. 18). This permits leveling of the sight (par. 21b (2)). The bipod legs are held in the folded position by the spring actuated leg lock buttons of the bipod front ring assembly. Pulling the bipod trip (figs. 16 and 17) releases the legs for unfolding (par. 16). The bipod slide block catch holds the bipod against folding

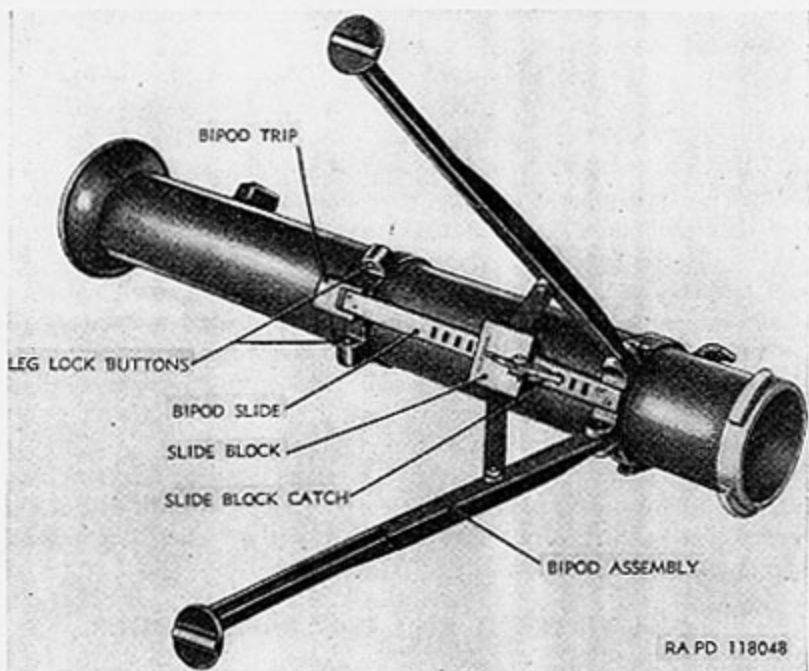

Figure 16. 3.5-inch Rocket Launcher M20B1—front barrel assembly.

in any position to which the bipod has been extended (par 17). The bipod is made of aluminum, but the bipod slide is steel and must be protected against corrosion by frequent cleaning and oiling (par. 35f).

c. The sight mounting bracket is on the left side of the rear barrel of the M20 launchers. It serves to secure the sight and range scale (sec. IX, ch. 3. On the M20B1 launcher, a support for the sight and range scale is cast integral with the rear barrel.

d. The contact springs (one on each side of the rear barrel (figs. 18 and 20) serve as handy clamps for the bare end of the blue contact wire from the rocket (par. 21c (8)). In clamping the bare end of

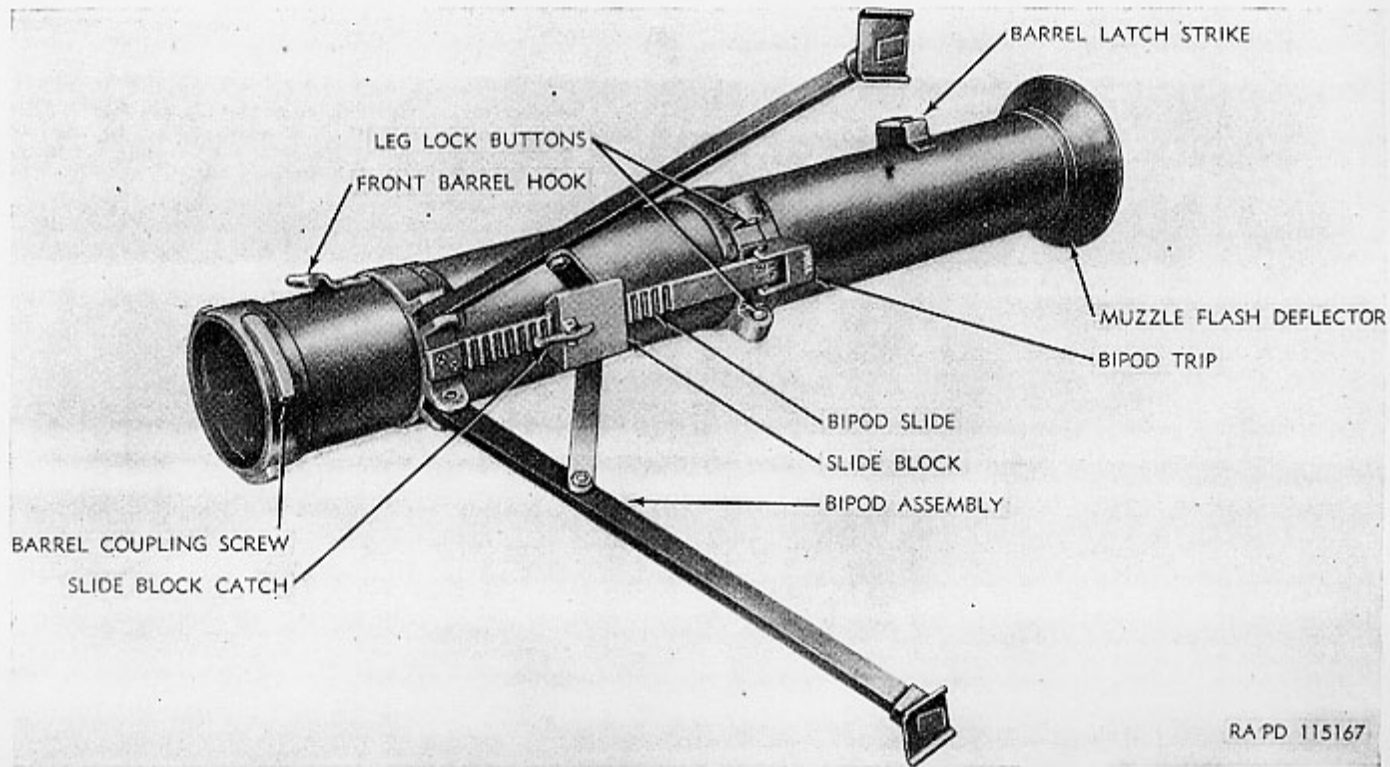

Figure 17. 3.5-inch Rocket Launcher M20—front barrel assembly.

the contact wire, the contact spring also makes good electrical contact with the wire. A contact spring clamp not only mounts both springs but connects them together electrically so that either contact spring may be used. An insulating band around the barrel under the contact spring clamp insulates the clamp from the barrel.

e. The contact lead wire connects the contact spring clamp to the firing mechanism. It is a stranded glass braid insulated wire which is run through an aluminum tube to protect it against damage. An insulator sleeve on the end of the aluminum tube separates the contact spring clamp from the aluminum tube. On the M20 launcher, the tube is clamped in place by the front and rear stock clamps. On the M20B1 launcher the tube is held in place by the stock and monopod supports on the rear barrel. The firing mechanism is grounded to the rear barrel (sec. VII, ch. 3). The complete firing circuit is as follows: from grounded firing mechanism, through insulated wire to contact spring clamp, through contact between spring and the bare end of the blue rocket contact wire, through the rocket contact wire to the rocket igniter, through the contact between notches in rocket fins and contactor blade, through contactor latch to contactor latch shunt, and the grounding of the shunt to the rear barrel completes the firing circuit.

f. The firing mechanism (sec. VII, ch. 3) is housed between the grips. On the M20 launcher, the stock with the monopod (sec. VIII, ch. 3) is clamped rigidly to the rear barrel between the sight mounting bracket and the contact spring clamp (fig. 20). On the M20B1 launcher the stock and monopod are similarly located but are mounted on supports which are cast integral with the rear barrel (figs. 18 and 19). The contactor latch housing assembly serves to engage the groove in the radial fin assembly of the rocket and hold the rocket in proper firing position in the launcher (par. 19). This contact also completes the firing circuit of the rocket. The breech guard facilitates loading.

Note.—Parts such as the muzzle deflector, the breech guard, the barrel hook and eye, the barrel latch strike, the grip support (bipod) stops, the barrel coupling screw and nut, stock clamp assembly, front clamp assembly, sight and range scale bracket, and contactor latch clamp occur as parts only on the M20 launcher. On the M20B1 launcher the function of these parts is performed by shapes cast integral with the barrels.

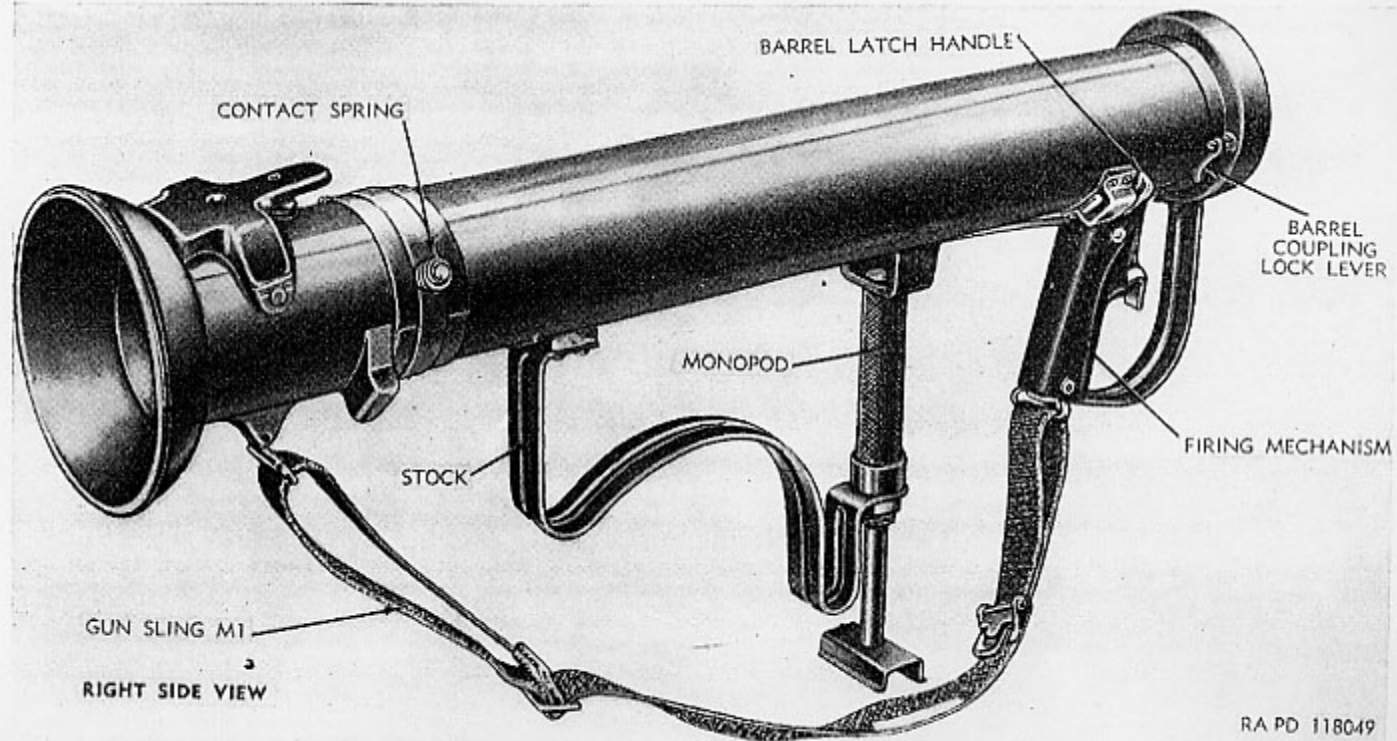
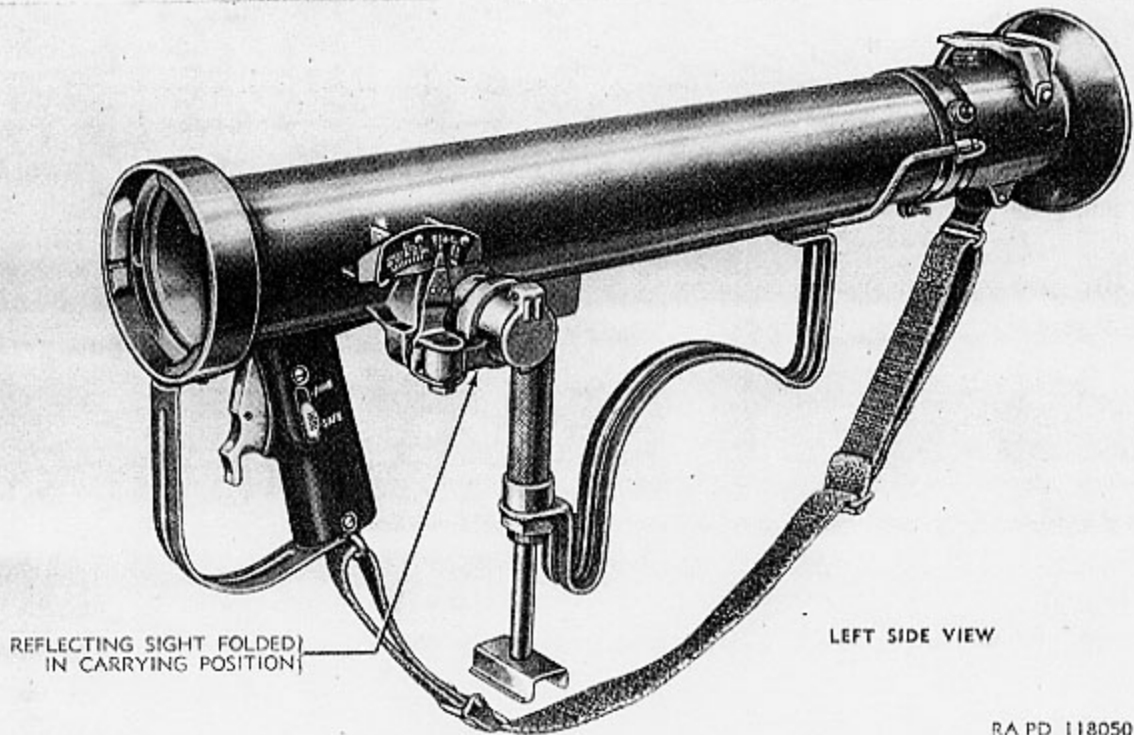

Figure 18. 3.5-inch Rocket Launcher M29B1—rear barrel assembly.



RA PD 118050

Figure 19. 3.5-inch Rocket Launcher M20B1—real barrel assembly.

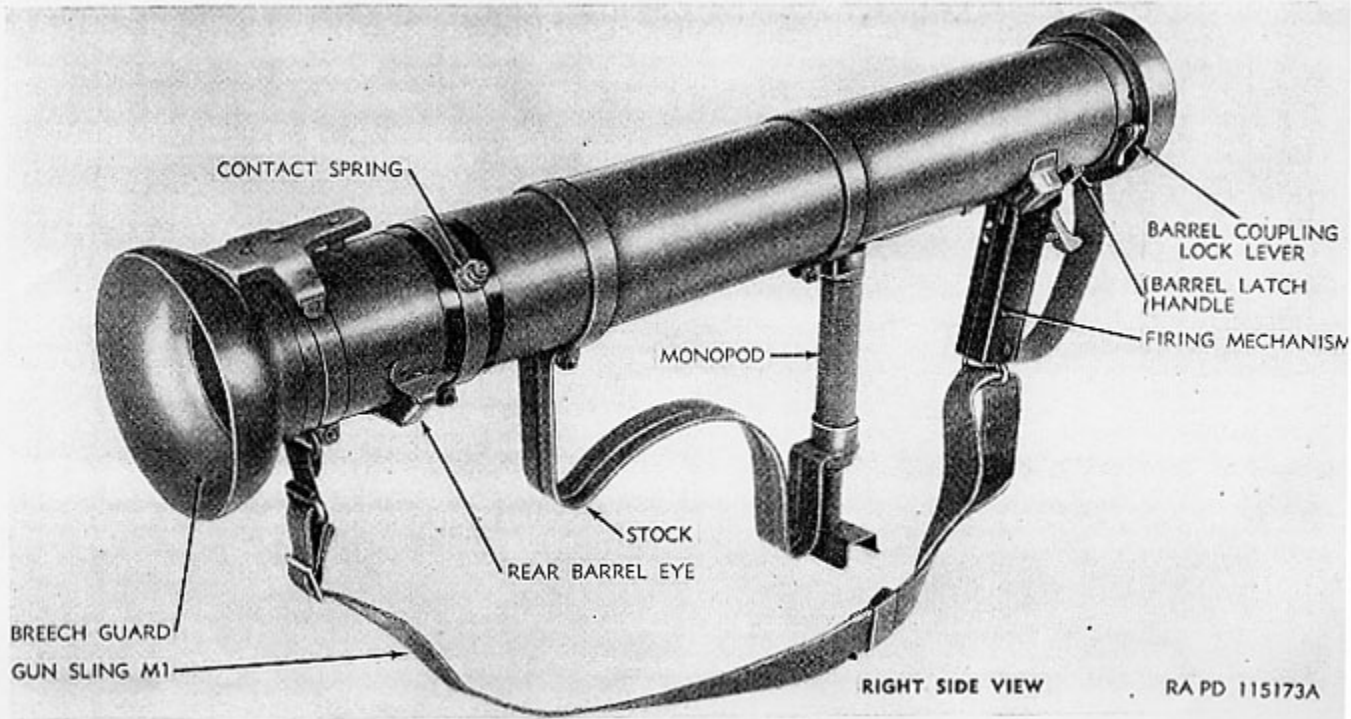

Figure 20. 3.5-inch Rocket Launcher M20—rear barrel assembly.

45. Disassembly and Assembly

a. **BIPOD FRONT RING ASSEMBLY.** The bipod ring contains two spring actuated leg lock buttons.

- (1) To remove the leg lock buttons from the bipod front ring, unscrew the set screw which retains each leg lock button and its spring in the recess in the front ring. Withdraw the spring and leg lock button.
- (2) To install the leg lock buttons in the bipod front ring, replace each button in its recess (spherical end first). Insert the spring, screw the retaining set screw in place and tighten it. The end of the tapped thread for the set screw provides a stop so that tightening the set screw will lock it in place.

b. **BIPOD TRIP** (figs. 21 and 22). The bipod trip pivots on a trip pin in the bipod slide and has two trip springs.

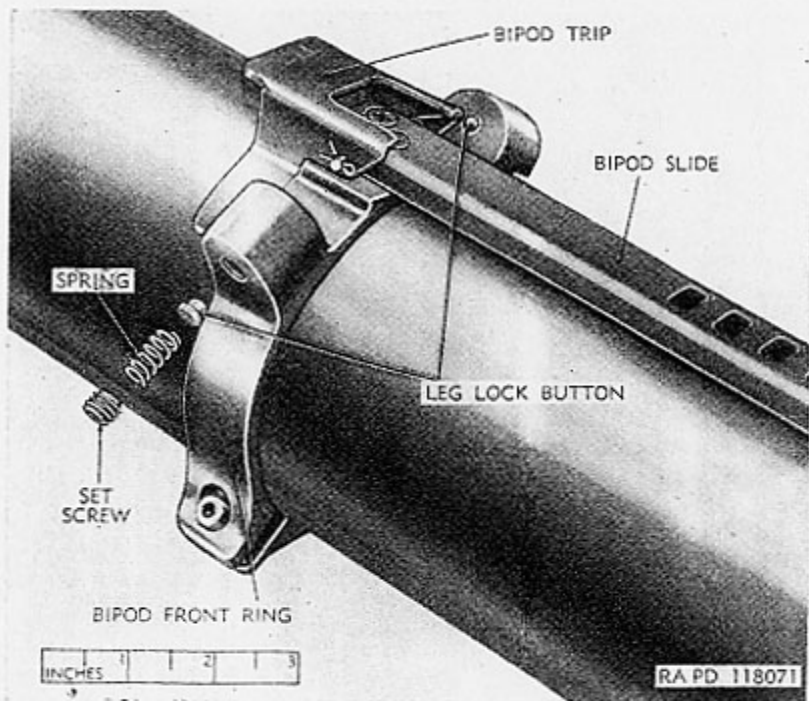

Figure 21. Leg lock button parts exploded.

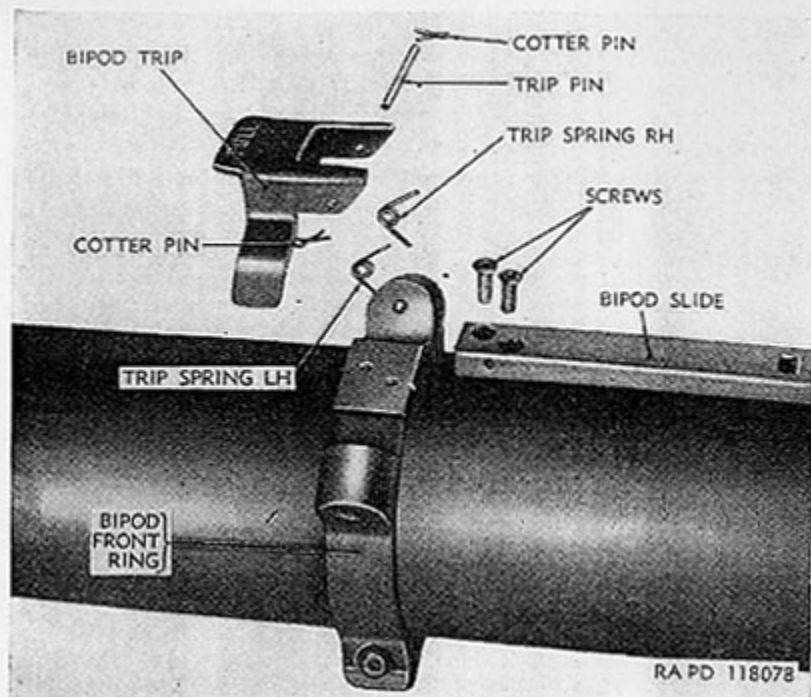

Figure 22. Bipod trip parts exploded.

(1) To disassemble, proceed as follows:

- (a) Pull the bipod trip to release the bipod legs so that the bipod can be extended out of the way.
- (b) Remove one of the cotter pins and pull the trip pin toward the other side far enough to free one side of the trip.

Caution: Do not let the trip spring fly out.

- (c) Pull the free side of the trip away from the trip pin and remove the spring.
- (d) Remove the other cotter pin and pull the trip pin far enough in the other direction to free the trip, again being careful not to let the trip spring fly out. Remove the trip spring.
- (e) There is not sufficient clearance to withdraw the trip pin from the slide. To remove the trip pin, it is necessary to remove the two screws fastening the slide to the bipod front ring, move the front ring forward on the barrel until it is out of the way, and withdraw the trip pin from the slide.

(2) To assemble, proceed as follows:

- (a) Insert the trip pin in its hole in the slide, return the bipod front ring to its proper position on the front barrel, and install the two screws which fasten the slide to the bipod front ring.
- (b) Pull the trip pin to one side until only one-fourth inch protrudes from the slide and slip the proper trip spring on the pin.

Note.—The trip springs are wound right-hand and left-hand. properly installed, the outer arm of each spring engages the trip, while the inner arm of each spring engages the bipod front ring.

- (c) Place the trip over the end of the slide so that the one side is in position to receive the trip pin.
- (d) Push the trip pin through to the other side until only one-fourth inch of the end protrudes from the slide and slip the other trip spring on the pin.
- (e) Push the trip up in position to receive the other end of the pin, withdrawing the pin a trifle as required to afford clearance for the trip to be pushed up into place.
- (f) Push the trip pin through to its proper position and install both cotter pins.

c. **BIPOD REAR RING LOCK.** Some M20 launchers are equipped with a continuous ring-type bipod rear ring (fig. 23).

(1) To remove the lock handle from this type of bipod rear ring, proceed as follows:

- (a) Release the lock (par. 18) and unscrew the lock stud.
- (b) Removing the lock stud frees the lock handle, and lifting the lock handle from the rear ring frees the lock spring and block so that they can be withdrawn from the rear ring.

(2) To install the lock handle in the bipod rear ring, proceed as follows:

- (a) Place the lock spring in its groove in the lock block so that the spring lies arch up.
- (b) Face the lock block so that its groove is parallel to the face of the rear ring and slide the block (with the spring) into the rectangular opening at the top of the ring.
- (c) Hold the lock handle vertical over the bipod rear ring with its hole end down and faced so that its main curvature (disregarding the return bend at the end of the handle) is to the right of the front barrel (rear ring lock is at top of the barrel). Insert the lower end of the handle between the ears at the top of the rear ring. It may be necessary to shift the block slightly to fit the handle in its groove.

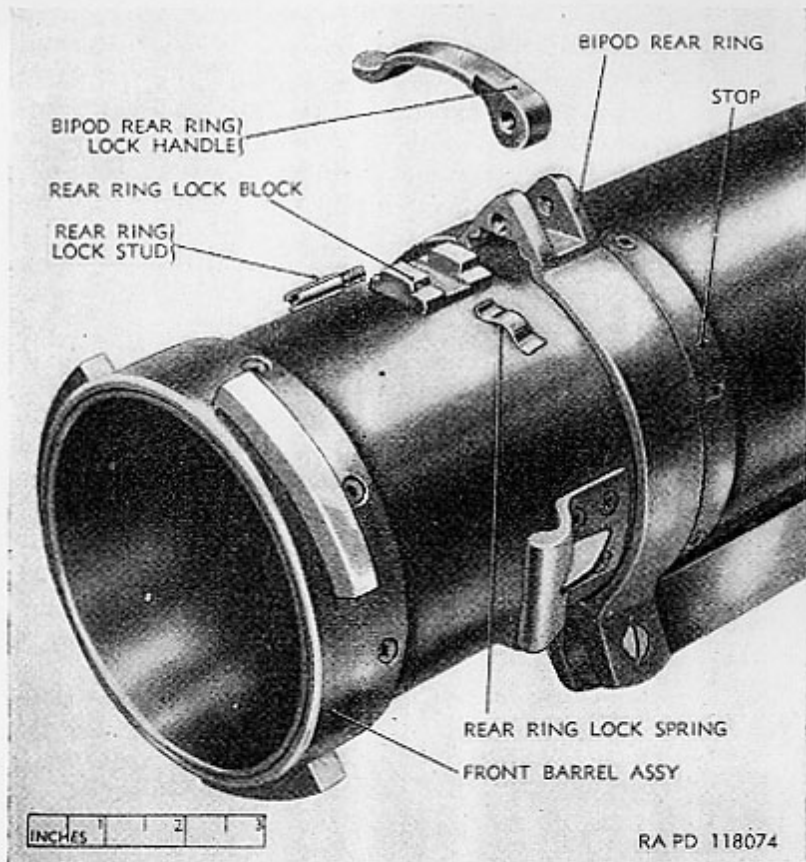

Figure 23. 3.5-inch Rocket Launcher M20 (early manufacture)—rear ring lock parts exploded.

(d) Align the hole in the handle with the holes in the ears and insert the lock stud. Screw the stud tight.

d. REMOVAL AND INSTALLATION OF BIPOD ASSEMBLY.

(1) Some M20 launchers are equipped with bipod assemblies having continuous ring-type front and rear rings. With these launchers, it is impossible to remove the bipod assembly from the front barrel without first removing the stops, the barrel latch strike, and the muzzle deflector. To install the bipod assembly, slip the front barrel into the rings and then install the stops, the barrel latch strike, and the muzzle deflector. The bipod assemblies will be removed only by ordnance maintenance personnel.

(2) M20B1 launchers and some M20 launchers are equipped with bipod assemblies having split ring-type front and rear rings (fig. 24).

(a) To remove this type of bipod from the front barrel, proceed as follows:

1. File off the end of rivet and drive out rivet which pins clamping spring and adjuster to upper yoke of rear ring.
2. Unscrew the socket-head screw and safety nut which fasten the lower yoke and upper yoke of the front ring together.

(b) To install this type of bipod on the front barrel proceed as follows:

1. Properly locate front barrel in the rings.
2. Install the socket-head screw and safety nut to fasten the upper yoke to the lower yoke of the front ring. Loosen screw $\frac{1}{3}$ to $\frac{1}{2}$ turn from clamping position to allow for free bipod rotation when bipod rear ring handle is unlatched.
3. Place adjuster in loop at free end of clamping spring. With bipod rear ring handle in unlatched position, aline one of the holes of the adjuster with the holes in the free end of the upper yoke and insert a new rivet. Move bipod rear ring handle to latched position. Select the hole of the adjuster which by trial provides a strong grip of the front barrel when clamped but which permits easy manipulation of the handle. Upset the end of the rivet.

e. **BIPOD SLIDE BLOCK CATCH** (fig. 8).

(1) To remove the bipod slide block catch, remove the cotter pin and withdraw the catch pin. Care must be exercised to keep the catch spring from flying out.

(2) To install the bipod slide block catch, place the catch spring in the catch so that the long arm of the spring fits in the slot of the catch at the lever end. Place the catch (with spring) in position on the slide block so that the holes aline. Replace the catch pin and secure with the cotter pin.

f. **BARREL COUPLING LOCK** (fig. 25).

(1) To remove the barrel coupling lock lever and screw, proceed as follows:

- (a) Remove the screw and lock washer. This frees the flat washer which retains the coupling lock lever.
- (b) Unhook the coupling lock spring from the coupling lock lever and carefully tap the lever off the screw.
- (c) Remove the spring and washer and unscrew the coupling lock screw.

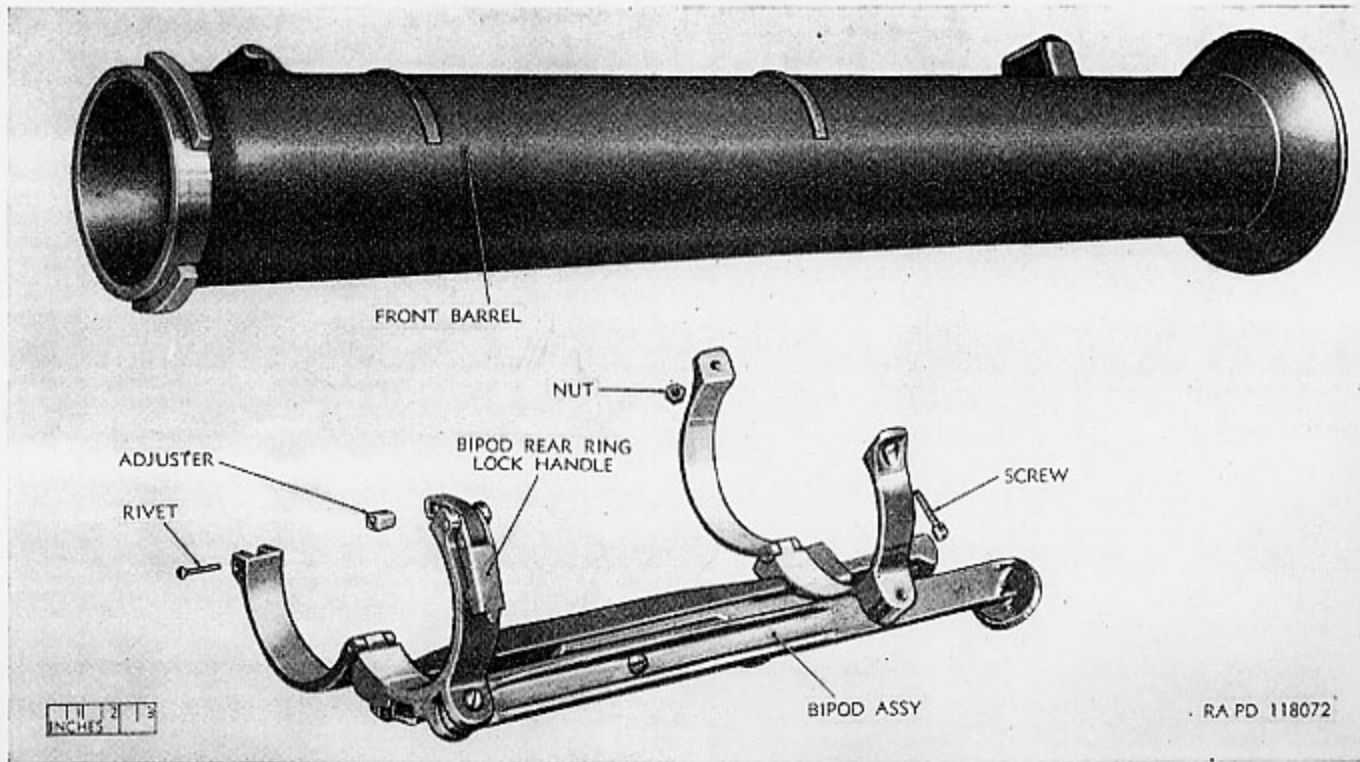

Figure 24. 3.5-inch Rocket Launcher M20B1—bipod removed from front barrel.

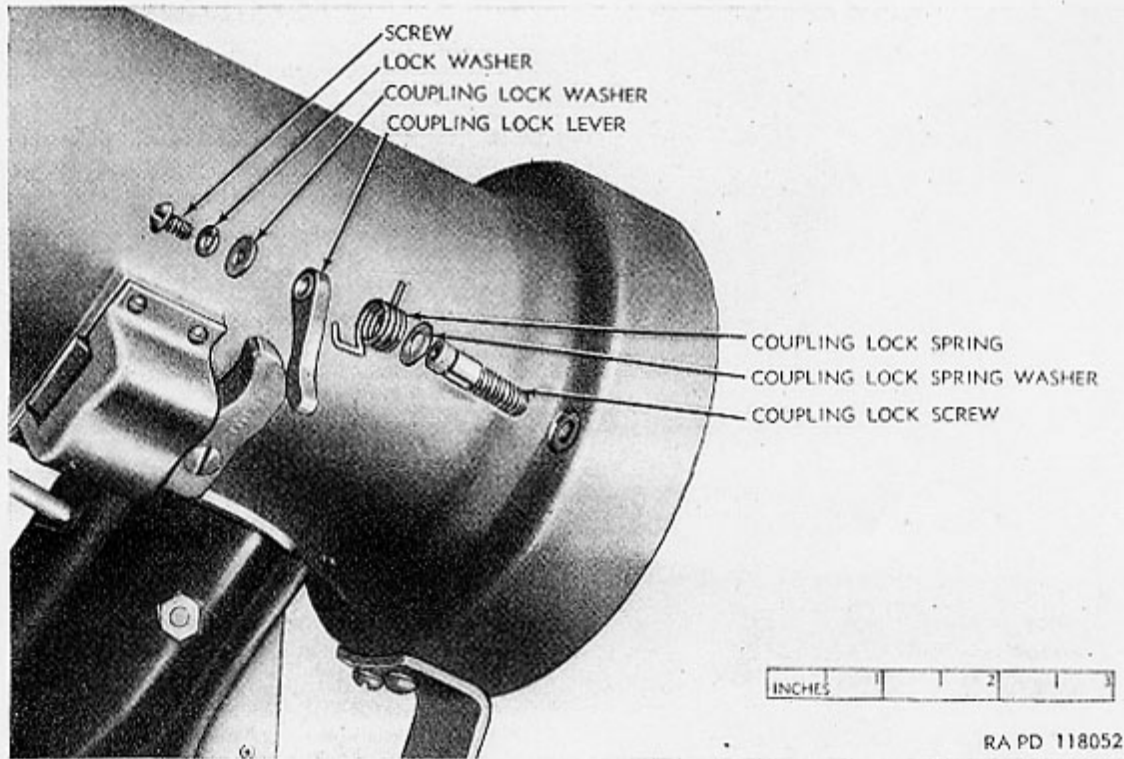

Figure 25. Barrel coupling lock parts exploded.

(2) To install the coupling lock screw and lever, proceed as follows:

- (a) Screw the front barrel into the rear barrel.
- (b) Screw the coupling lock screw into its tapped hole until it prevents rotation of the front barrel.
- (c) Slip the washer and then the coupling lock spring on the coupling lock screw.
- (d) Assemble coupling lock lever onto the coupling lock screw in locked position (pointing down and faced so that curvature at end of lever is away from barrel). Light tapping may be necessary to seat lever completely.
- (e) Hook spring over lever.
- (f) Slip the lock washer and the flat washer on the screw in such order that the lock washer engages the head of the screw.
- (g) Install the screw (with the two washers on it) in its tapped hole in the coupling lock screw and tighten it so as to clamp lever firmly.

Note.—In all three locked positions, the front barrel must be locked firmly in the rear barrel without play.

g. BARREL LATCH (fig. 26). The steel barrel latch bolt mounts in an aluminum frame which is fastened to the rear barrel in the M20 launcher. In the M20B1 launcher the barrel latch frame is replaced by a barrel latch housing which mounts on a pad cast integral with the rear barrel.

(1) To remove the barrel latch bolt, proceed as follows:

- (a) Unscrew the barrel latch handle screw. This frees the barrel latch handle from the barrel latch bolt.
- (b) Withdraw the barrel latch bolt. The two springs usually will stay on the pins and be withdrawn with the bolt. If they do not stay on the pins, fish the springs out of the frame or housing.

(2) To install the barrel latch bolt, proceed as follows:

- (a) Slip the springs on the pins of the barrel latch bolt.
- (b) Insert the barrel latch bolt in the frame or housing and fasten the barrel latch handle to the bolt with its screw. Tighten the screw securely.

h. CONTACTOR LATCH (fig. 27). The contactor latch housing assembly mounts on the contactor latch lamp (par. 19*a*) of M20 launchers and on bosses cast integral with the rear barrel of M20B1 launchers.

(1) To remove the contactor latch body from the contactor latch clamp or from the mounting bosses, proceed as follows:

- (a) Remove the cotter pin from each contactor latch pin and withdraw both contactor latch pins.

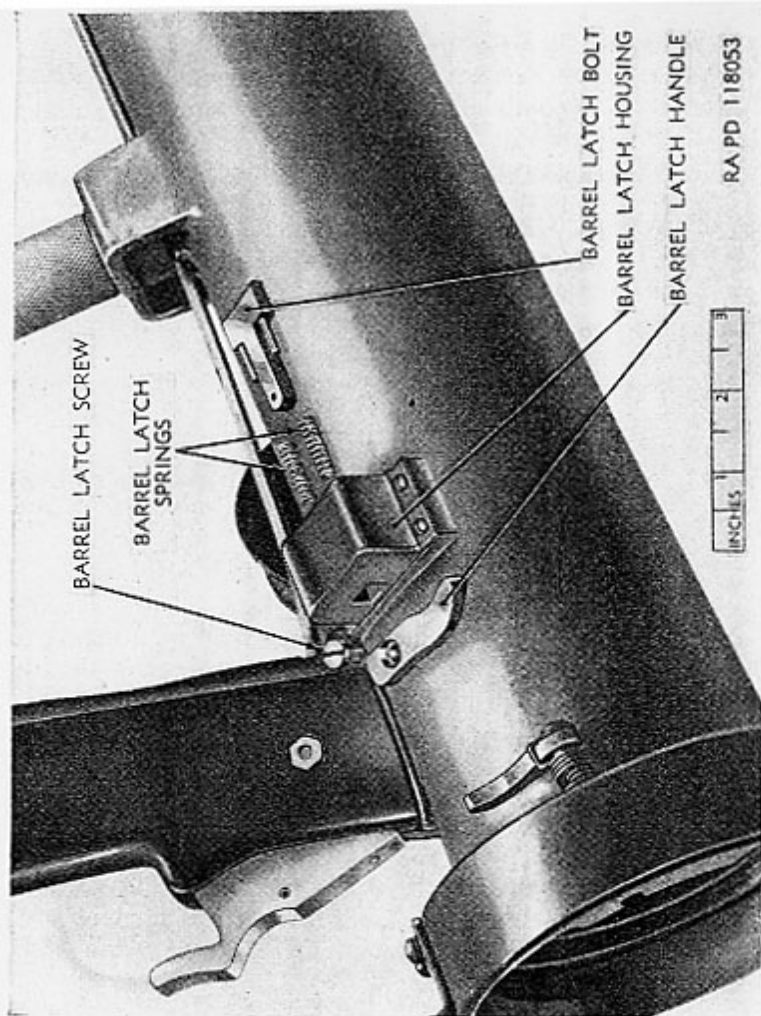

Figure 26. Barrel latch bolt and associated parts.

- (b) Raise the contactor latch body a trifle. This straightens the contactor latch shunt to some extent and also frees the contactor latch spring. Unless care is exercised, the spring will be dropped.
- (c) Disengage the contactor latch shunt from the barrel by removing the screw. The contactor latch stud which carries the latch spring also clamps the shunt to the contactor latch body.

Note.—If the shunt is not clamped firmly to the contactor latch body, hammer the head of the contactor latch stud to upset the head further and thereby tighten the stud.

(2) To install the contactor latch body on the contactor latch clamp, proceed as follows:

- (a) By means of the screw, firmly secure the end of the contactor latch shunt to the barrel.
- (b) Place the latch body in its proper position, protruding through the opening in the breech guard.
- (c) Slip the contactor latch spring over the stud.
- (d) Align the hole in the contactor latch body in the bosses of the contactor latch clamp for M20 launchers or in the bosses cast integral with the rear barrels of M20B1 launchers. Insert both contactor latch pins and secure with cotter pins.

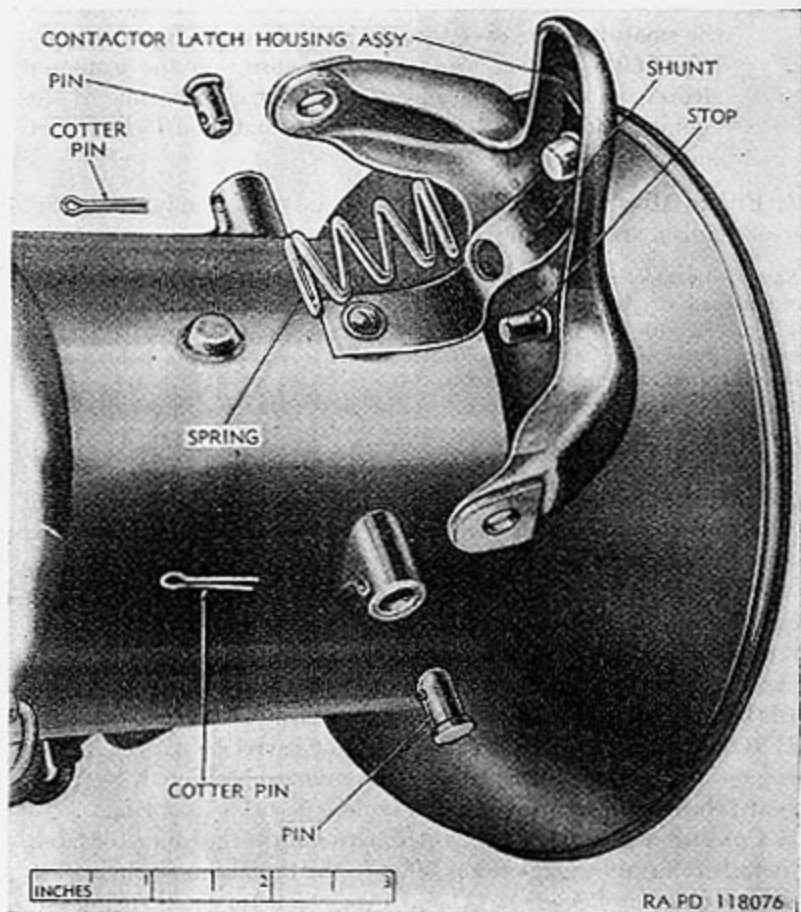

Figure 27. Contactor latch parts exploded.

i. **MONOPOD.** The assembly and disassembly of the monopod is covered in paragraph 51.

j. **CONTACT SPRING CLAMP.** Remove the contact spring clamp requires opening the soldered connection of the contact lead wire on the clamp. This may be done only by ordnance maintenance personnel.

- (1) Access to the insulating band (under the clamp) and to the insulator sleeve (on the end of the aluminum tube of the contact lead wire) can be obtained, for the purposes of inspection, by simply loosening the clamp. Remove the screw, nut, and lock washer from the clamp (fig. 28).
- (2) To install the contact spring clamp, wrap the insulating band around the barrel and pull the clamp over it in its proper position. See that the clamp is approximately centered on the insulating band and that the clamp is faced around so that the small loop fits over the insulator sleeve on the aluminum tube of the contact lead wire. Be sure that the insulator sleeve completely separates the clamp from the tube of the contact lead wire. Install the screw, nut, and lock washer in the clamp and tighten them.

k. **FIRING MECHANISM.** The assembly and disassembly of the firing mechanism are given in paragraph 48.

Note.—Always clean (pars. 35 and 37) and inspect all parts before making any reassembly. Any parts which show wear or distortion will be discarded and replaced with new parts. All springs will receive particularly critical inspection. Steel parts must be protected against corrosion by a light film of preservative lubricating oil (par. 46i).

46. Maintenance

Maintenance of the barrels consists chiefly of cleaning and inspecting to discover worn or broken parts to be discarded and replaced by new parts.

a. **BARREL COUPLING LOCK.** Check functioning of barrel coupling lock. Failure to lock the barrels may be due to a worn or damaged screw. Failure of the lock to hold its lock position indicates a worn or broken barrel coupling lock spring. Disassemble (par. 45*f*), discard the worn or broken parts, and replace them with new parts.

b. **BARREL LATCH.** Check functioning of barrel latch. If it fails to engage and hold the barrel latch strike, disassemble it (par. 45*g* (1)). Discard the barrel latch springs and replace it with new springs.

c. **CONTACTOR LATCH.** Check the functioning of the contactor latch. If it fails to firmly engage the notches in the radial fins of the rocket, disassemble (par. 45*h* (1)). Discard the contactor latch spring and replace it with a new spring.

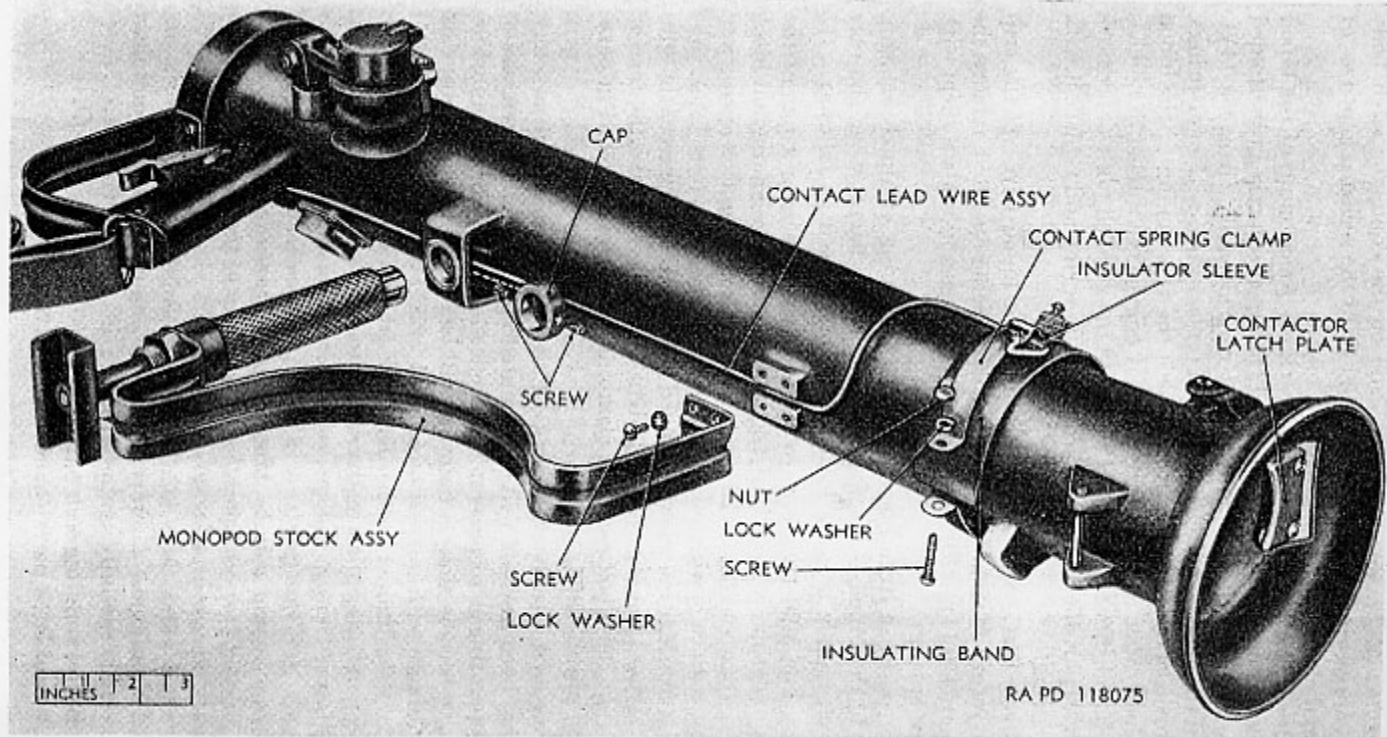

Figure 28. Insulating band and insulator sleeve exposed for inspection.

Caution: Make sure that the blade on the contactor latch body which contacts the notches in the radial fin of the rocket is kept free of paint and clean.

d. **BIPOD LEG LOCK BUTTONS.** Check the functioning of the bipod leg lock buttons. If they fail to hold the bipod securely in the folded position, remove them from the front ring assembly (par. 45a (1)). Discard the leg lock button springs and replace them with new springs.

e. **BIPOD SLIDE BLOCK CATCH.** Check the functioning of the bipod slide block catch. If it fails to properly engage the ratchet or notches on the bipod slide so as to hold the bipod in extended position, remove the catch (par. 45e (1)). Discard the catch spring and replace it with a new spring.

f. **BIPOD TRIP.** Check functioning of the bipod trip. If the trip fails to return to its original position after being operated, remove the trip (par. 45b (1)). Discard both trip springs and replace them with two new springs.

g. **BIPOD REAR RING LOCK.** Check functioning of bipod rear ring lock. If the bipod is not firmly locked to the barrel when the rear ring lock handle is in its locked position, proceed as follows:

(1) For M20 launchers equipped with bipod rear rings of the continuous ring type (fig. 23), remove the handle and block (par. 45c (1)). Discard the bipod rear ring lock spring and replace it with a new spring.

(2) For M20 launchers equipped with bipod rear rings of the split ring type (fig. 24) and M20B1 launchers, adjust the tension of the bipod rear ring clamping spring as described in paragraph 45d (2).

h. **RETOUCH PAINTED SURFACES.** Parts of the launcher from which paint has been worn off will be repainted (par. 38b). The purpose of such repainting is to prevent light reflection from worn spots which may have become shiny. Painting will be done with the utmost care in accordance with instructions in TM 9-2851 and the application of paint strictly limited to the damaged area. Care will be observed that no paint is applied inadvertently to other parts of the launcher. *Do not paint contact springs, contact surfaces of contactor latch, or the sight. Polished parts, or moving parts, where wear occurs and where functioning may be affected by the application of paint, will not be painted (for example; the ring surfaces of the front barrel under the front and rear bipod rings).*

i. **STEEL PARTS.** Most of the parts of front and rear barrels are made of aluminum. However, the following are steel parts and must be protected especially against rusting:

Barrel coupling lock parts.

Barrel latch parts (handle is aluminum).

- Bipod leg lock buttons.
- Bipod slide.
- Bipod slide block catch.
- Bipod rear ring lock parts.
- Contacto latch parts (except the shunt).
- Firing mechanism trigger bar.
- All pins, screws, springs, and washers.

Unpainted surfaces of steel parts will be cleaned with rifle bore cleaner or dry-cleaning solvent and thoroughly dried at intervals prescribed in paragraph 41. If the parts are rusted, crocus cloth may be used to remove the rust. The use of harsher abrasives is prohibited.

Section VII. FIRING MECHANISM

47. General

The firing mechanism is housed within the grips and is secured to the grip support on the under side of the rear barrel. It consists of a magneto, trigger, and safety mechanism. The magneto consists of two magnets housing a coil of wire which in turn houses a steel armature. When the trigger is squeezed, the armature rocks in the coil and generates sufficient current to ignite the rocket (par. 11).

a. Some M20 launchers are equipped with electric firing mechanism C7313326 (single action—fig. 7). In this firing mechanism the rocker arm and armature spring provide a snap action to the movement of the armature. The safety switch is located on the rear side of the left grip. When the safety switch is moved manually to the "SAFE" position, the magneto coil is shorted out of the electric system so that no current reaches the rocket (par. 12*a*). The magneto generates current when the trigger is squeezed and also when it is released. Springs return the trigger to its original position.

b. Some M20 launchers and the M20B1 launchers are equipped with electric firing mechanism B7140325 (double action—fig. 7). In this mechanism the armature is rotated away from the pole faces and returned to the pole faces by squeezing the trigger. A snap action is imparted to the movement of the armature in both directions. When the trigger is squeezed, the latch on the trigger presses the trigger bar back against a spring on the armature spring sleeve. The armature spring inside the sleeve is also compressed as the trigger bar is pressed back. The armature is held against the pole faces by magnetic force. When the compression of the armature spring exceeds the magnetic force, the armature is rotated away from the pole faces. As soon as contact between the armature and the pole faces is broken, the magnetic force being applied to the armature is greatly

diminished by the gap, permitting the spring to snap the armature away from the pole faces. At this point, the latch on the trigger releases the trigger bar permitting it to spring forward and carry the armature spring sleeve and armature with it, propelled by the compression of the spring on the armature spring sleeve. The magneto of this firing mechanism only generates current while the trigger is squeezed. A spring returns the trigger to its original position.

c. Due to the superior snap action and the automatic use of the return motion, the electrical output of firing mechanism B7140325 is almost three times that of firing mechanism C7313326.

48. Disassembly and Assembly

a. ELECTRIC FIRING MECHANISM C7313326 (SINGLE ACTION—FIG. 7).

(1) *Disassembly.*

- (a) Unscrew the four screws which secure the trigger guard to the grips (fig. 29). Unscrew the two screws which secure the trigger guard to the launcher, taking care not to drop the lock washer which is on each screw.
- (b) Unscrew the two screws and nuts which fasten the two grips together. The grips now are free from the firing mechanism. When the left grip is removed, the safety switch is a loose part in the left grip.

Caution: With the grips removed from the firing mechanism, the magnetic field tends to pick up metal particles. Work space, therefore, will be kept as clean as possible.

- (c) At the firing mechanism, disconnect the contact lead wire which leads to the contact spring clamp. Heat and disconnect the soldered joint between the wire and terminal on firing mechanism rear plate assembly.

Note.—This operation must be performed only by ordnance maintenance personnel.

- (d) Remove the cotter pin from the trigger pin and withdraw the trigger pin.
- (e) Unscrew the screw and nut which secure the firing mechanism to the grip support on the rear barrel, taking care not to drop the two lock washers.
- (f) To remove the trigger, drive out the trigger retaining pin. This frees the trigger from the toggle pin of the rocker arm. The trigger spring and washer now can be slipped off the toggle pin.

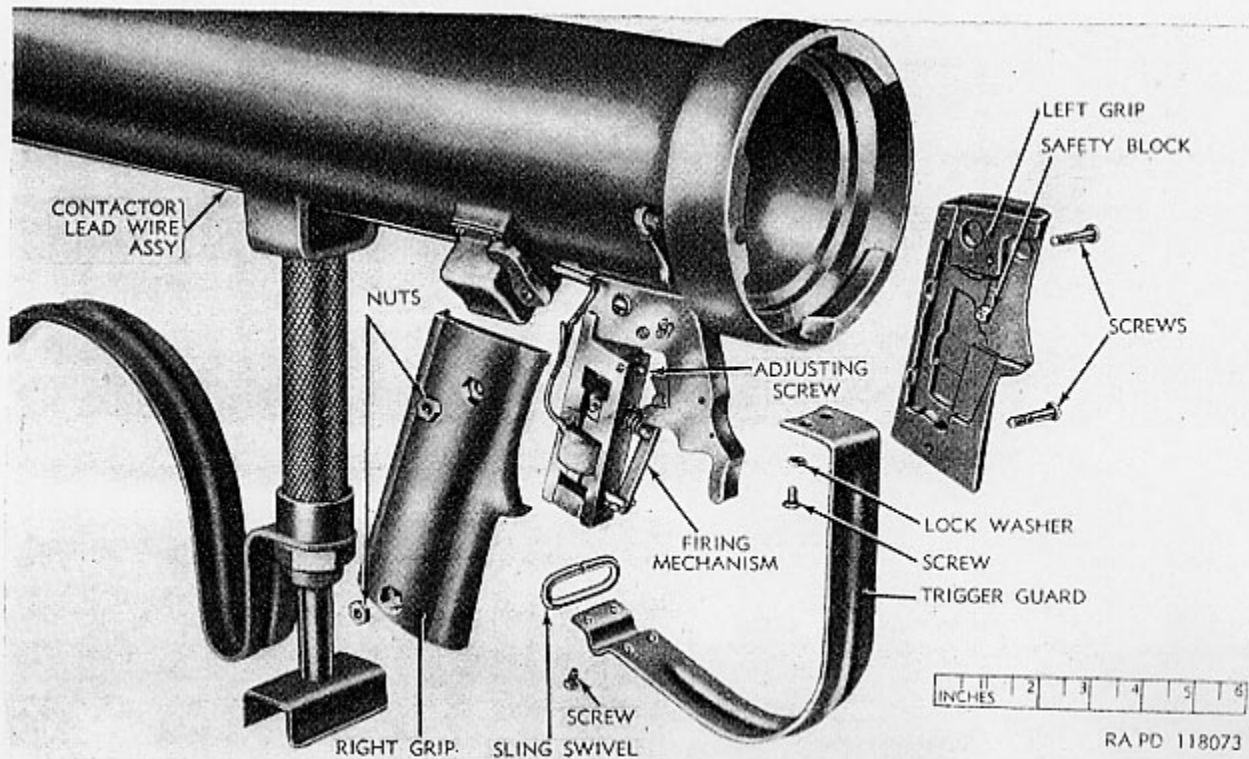

Figure 29. Firing Mechanism B7140325 (double action)—grips removed.

Caution: Further disassembly of the firing mechanism is prohibited. If the screws which hold the front and rear plates of the firing mechanism together are loosened or removed, the magnets will lose their magnetic charge and, as a result, the firing mechanism will not function.

(2) *Assembly.*

- (a) If the trigger has been removed, slip the washer and trigger spring on the toggle pin of the rocker arm. Insert the toggle pin in its seat in the trigger, aline the hole in the toggle pin with the holes in the trigger, and drive in the trigger retaining pin.
- (b) Secure the firing mechanism to the grip support on the rear barrel.
 1. Aline the holes of the grip support on the barrel and the support bracket of the firing mechanism, slip a lock washer on the screw, and insert the screw.
 2. Slip another lock washer on the end of the screw and engage the nut on the screw. Tighten the screw and nut.
- (c) Place the upper end of the trigger over the grip support and support bracket so that the holes in the trigger, the support, and the bracket aline. Insert the trigger pin and install the cotter pin.
- (d) Connect the contact lead wire, which leads to the contact spring clamp, at the firing mechanism. Be sure that both the lead from the magneto coil and the contact lead wire from the contact spring clamp are soldered to the terminal. Do not use excess solder. Do not permit solder to drip on other parts of the firing mechanism.

Note.—Soldering must be performed only by ordnance maintenance personnel.

- (e) Oil the firing mechanism (par. 35*d*).
- (f) Replace the safety switch in the left grip with the tapered part of the switch contact upward.
- (g) Place the grips in position on the firing mechanism. Adjust the position of the firing mechanism so as to aline the holes in the support and bracket for the upper screw and fasten the grips together with the two screws and nuts. The lower screw is slightly longer.
- (h) Place the sling swivel in its loop in the trigger guard and fasten the trigger guard to the grips by means of the four screws. Fasten the trigger guard to the launcher by means of the two screws provided, using lock washers on these screws.

(1) *Removal.*

- (a) Unscrew the four screws which secure the trigger guard to the grips (fig. 29). Unscrew the two screws which secure the trigger guard to the launcher, taking care not to drop the lock washer which is on each screw.
- (b) Unscrew the two screws and nuts which fasten the two grips together. The grips are now free from the firing mechanism. The safety is assembled as a part of the left grip and is not to be disassembled.

Caution: With the grips removed from the firing mechanism the magnetic field tends to pick up iron and steel particles. Work space, therefore, will be kept as clean as possible.

- (c) At the firing mechanism, disconnect the contact lead wire which leads to the contact spring clamp (fig. 30). Remove the insulating tape, heat and disconnect the soldered joint between the lead from the field coil and the contact lead wire.

Note.—This operation must be performed only by ordnance maintenance personnel.

- (d) Remove the cotter pin from the trigger pin and withdraw the trigger pin (fig. 30). This frees the trigger and latch assembly. Take care not to drop the trigger spring.
- (e) Unscrew the screw and nut which secure the firing mechanism to the grip support on the rear barrel, taking care not to drop the two lock washers.

Note.—Disassembly of the electric firing mechanism B7140325 is prohibited. Replace the firing mechanism upon the failure or malfunction of any part (par. 49b(2)).

(2) *Adjustment.*

- (a) Wear or loosening of the adjusting screw (fig. 29) may require resetting of this screw. To reset the adjusting screw, loosen the set screw which locks the position of the adjusting screw. Insert a small screwdriver through the hole in the bottom plate and turn the adjusting screw clockwise (slightly) to take up wear.
- (b) If a double click can be distinguished when the trigger is squeezed the nose of the adjusting screw is too far away from the trigger latch. The best adjustment is determined by testing the electrical output of the magneto (par. 73).

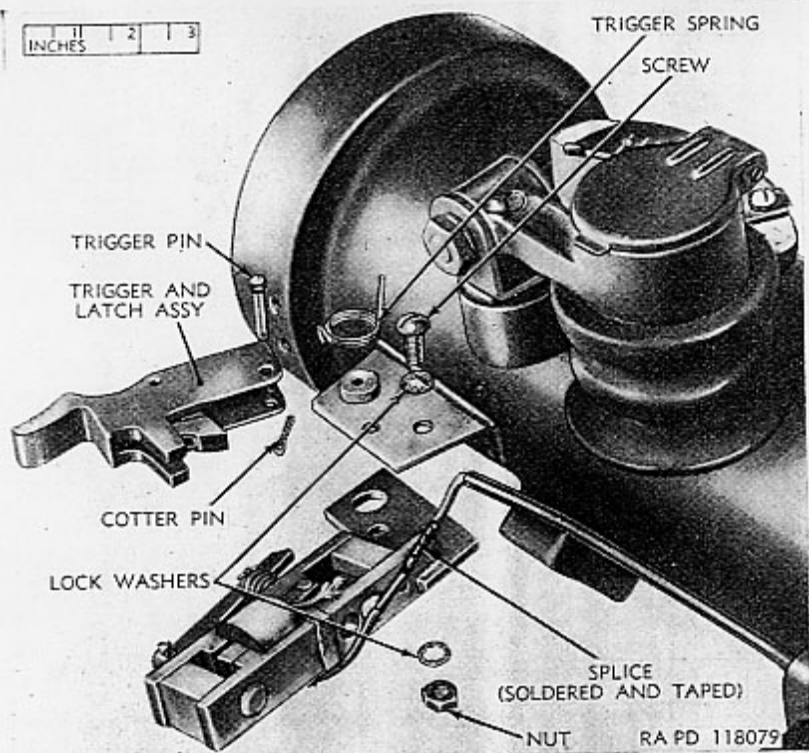

Figure 30. Firing Mechanism B7140325 (double action)—removed from launcher but not disconnected

- (c) Tighten the set screw to lock the position of the adjusting screw when the best adjustment has been determined.
- (3) *Installation.*
 - (a) Secure the firing mechanism to the grip support on the rear barrel.
 1. Aline the holes of the grip support on the barrel and the support bracket of the firing mechanism, slip a lock washer on the screw, and insert the screw.
 2. Slip another lock washer on the screw and engage the nut on the screw. Tighten the screw and nut.
 - (b) Place the trigger spring around the bushing on the grip support and hook the spring around the grip support and into the U-shaped slot of the bracket.
 - (c) Place the upper end of the trigger over the trigger spring, the grip support, and support bracket of the firing mechanism so that the holes in the trigger, the grip support, and

the bracket aline. Insert the trigger pin and install the cotter pin.

- (d) Splice the contact lead wire, which leads to the contact spring clamp to the lead from the field coil. Solder the splice and apply tape to the soldered connection. Do not use excess solder. Do not permit solder to drip on other parts of the firing mechanism.

Note.—Soldering must be performed only by ordnance maintenance personnel.

- (e) Oil the firing mechanism (par. 35e).
- (f) Place the grips in position on the firing mechanism. Adjust the position of the firing mechanism so as to aline the holes in the support and bracket for the upper screw and fasten the grips together with the two screws and nuts.
- (g) Place the sling swivel in its loop in the trigger guard and fasten the trigger guard to the grips by means of the four screws. Fasten the trigger guard to the launcher by means of the two screws provided, using lock washers on these screws.

49. Maintenance

a. ELECTRIC FIRING MECHANISM C7313326 (SINGLE ACTION-FIG. 7). If any part of the firing mechanism C7313326 (single action-fig. 7) has become worn or broken so that the launcher does not fire, the firing mechanism will be replaced as a unit (par. 48a).

Caution: Disassembly of the firing mechanism beyond that indicated in paragraph 48a (1) is prohibited because disassembly decreases the magnetic power of the magnets. Tests have shown that disassembly decreases the output of the magneto from 30 to 40 percent.

b. ELECTRIC FIRING MECHANISM B7140325 (DOUBLE ACTION-FIG. 7).

- (1) If the slot in the trigger becomes clogged with dirt, remove the trigger and latch assembly (fig. 30) for cleaning.
 - (a) Remove the cotter pin from the trigger pin and remove the trigger pin. This frees the trigger and the trigger spring.
 - (b) Clean the slot in the trigger. Lubricate the trigger latch (par. 35e (2)). See that the latch moves freely. Lubricate the roller on the trigger latch and see that it rotates easily. Lubricate firing mechanism (par. 35e). Wipe off excess oil.
 - (c) Place the trigger spring on the bushing of the grip support and hook it around the support and into the U-shaped slot of the firing mechanism bracket. Slip the trigger over the

trigger spring and over grip support and bracket. Aline the holes in the trigger with the holes in the support and bracket. Insert the trigger pin and install the cotter pin in the trigger pin.

- (2) If any part of firing mechanism B7140325 has become worn or broken so that the launcher does not fire, the firing mechanism will be replaced as a unit.

Section VIII. MONOPOD STOCK ASSEMBLY

50. General

This group consists of a shoulder rest stock and a monopod mounted on clamps around the rear barrel of the M20 launcher between the sight mounting bracket and the contact spring clamp. On the M20B1 launcher the monopod stock assembly is similarly located but it is mounted on supports cast integral with the rear barrel. The monopod is used in conjunction with the bipod on the front barrel to form a three-legged stand for the weapon. The launcher stands on the bipod and monopod when firing from the prone position. The height of the monopod can be adjusted by rotating the sleeve body of the monopod (par. 15*b*), and manipulation of this adjustment provides stable control of the elevation of the launcher.

51. Disassembly and Assembly

a. DISASSEMBLY (figs. 31 and 32).

- (1) For the M20 launcher the monopod stock assembly can be separated from the rear barrel by removing the nuts and lock washers from the two screws which fasten the front and rear clamps of the monopod stock to the rear barrel. Withdraw the screws and pry the clamps off the barrel, being careful not to damage the aluminum tube of the contact lead wire. These clamps do not exist on the M20B1 launcher. Remove four screws which fasten the stock to a pad on the rear barrel of the M20B1 launcher.
- (2) For both M20 and M20B1 launchers unscrew the monopod leg nut and remove the lock washer. Slide the monopod foot off the end of the monopod leg.
 - (a) Unscrew the adapter nut and remove the spring washer from the adapter and slide the stock and adapter sleeve off the monopod.
 - (b) Remove the two adapter keys from the adapter.
 - (c) Slide the adapter off the monopod leg.

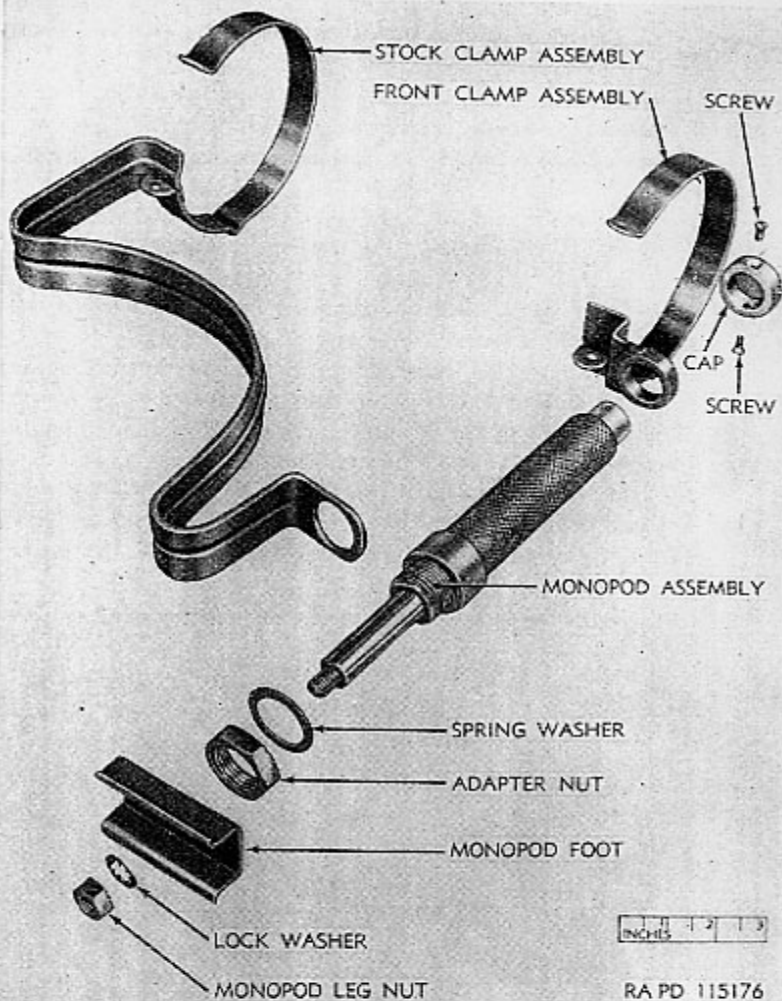

Figure 31. 3.5-inch Rocket Launcher M20—monopod and stock parts exploded.

- (d) The monopod leg key is held in the adapter by the leg key pin. It need not be removed unless it shows corrosion. In that case, drive out the pin from its hole in the adapter and remove the key (with the pin in it, fig. 33).
- (e) Using a small punch with a flat end, unstake the two mounting screws and unscrew them from the knurled monopod sleeve body. Slide the sleeve body off the monopod spiral slot body.

- (f) Using a small punch with a flat end, unstake the two mounting screws and unscrew them from the monopod cap. Remove the cap.
- (g) Unscrew the leg screw and slide the spiral slot body from the monopod leg.

Note.—Only ordnance maintenance personnel are to remove staked screws.

b. ASSEMBLY (figs. 31 and 32).

- (1) Only the keys, screws, and washers are steel. (On M20 launchers, the bracket of the front clamp assembly is steel.) These steel parts must be examined for rust. Remove rust spots with rifle bore cleaner and crocus cloth.
- (2) Insert the monopod leg in the spiral slot body in such manner that the end of the body having the arc keyway for the Woodruff keys of the adapter and the end of the leg having the screw thread are at the same end of the assembly. Slide the body on the leg until the tapped hole for the leg screw appears directly under the spiral slot. Insert the leg screw through the slot and engage the tapped hole in the leg. Tighten the leg screw.

Note.—The leg screw must not protrude beyond the spiral slot body.

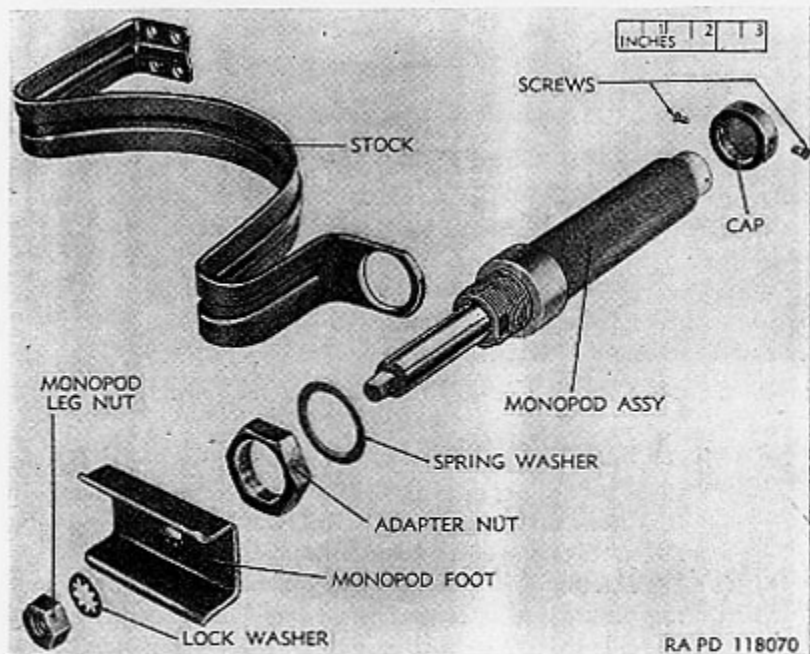

Figure 32. 3.5-inch Rocket Launcher M20B1—monopod and stock parts exploded.

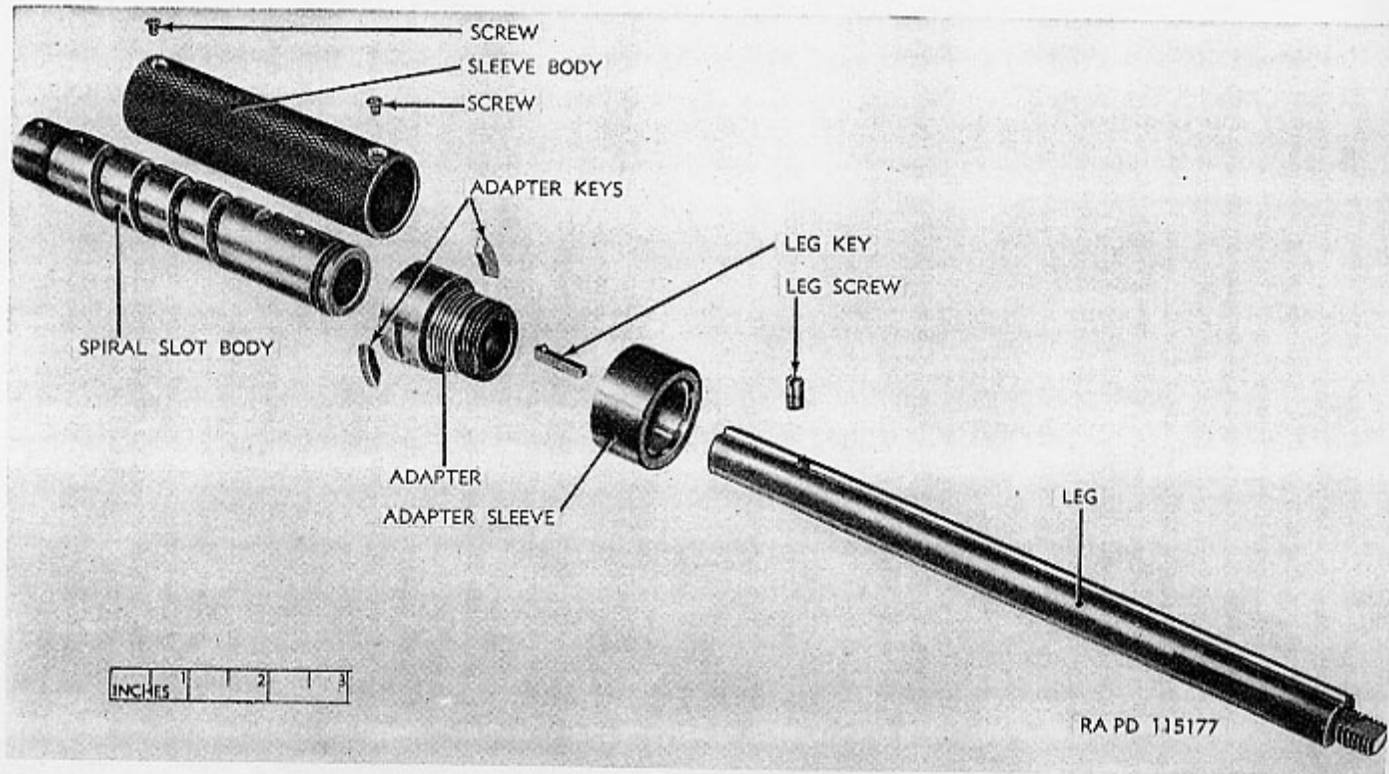

Figure 33. Monopod parts exploded.

- (3) For M20 launchers insert the upper end of the assembled leg and body into the bracket of the front clamp. For M20B1 launchers make sure that the aluminum tube of the contact lead wire assembly is placed in its notch on the barrel in the monopod support and insert the upper end of the assembled leg and body in the monopod support cast integral with the rear barrel. Place the cap over the upper end of the spiral slot body. Face it around so that the two mounting screw holes aline with the tapped holes in the body. Install the mounting screws. The mounting screws for the cap are slightly longer than the mounting screws for the monopod sleeve body. Tighten the screws and stake them.
- (4) Slide the knurled monopod sleeve body over the spiral slot body. Face it around to aline the mounting screw holes of the sleeve body with the tapped holes of the spiral slot body and install the two mounting screws. Tighten the screws and stake them.
- (5) If the leg key was removed from the adapter, insert the key (with the leg key pin in it, fig. 33) in the keyway of the adapter, fitting the leg key pin in its hole in the adapter.
- (6) Slide the adapter over the end of the monopod leg and the spiral slot body engaging the leg key in the keyway on the leg. Adjust the position of the adapter so that the key slots of the adapter aline with the keyway encircling the end of the spiral slot body. Insert the two adapter keys and slide the adapter sleeve over the adapter.
- (7) Slide the stock over the leg and adapter. Slip the spring washer over the adapter and place it against the stock. The spring washer will be placed in such manner that the inner portion of the washer is raised away from the stock. Engage the adapter nut in the screw thread of the adapter and tighten the nut sufficiently to flatten the spring washer.

Note.—It is necessary to clamp the monopod cap to prevent turning while tightening the adapter nut.

- (8) Place the foot at the end of the leg and turn it until the flat of the hole in the foot alines with the flat on the end of the leg. Slip the foot on the end of the leg. The channel of the foot should face down (away from the leg). Slip the lock washer on the end of the leg and engage the monopod leg nut in the thread at the end of the leg. Tighten the leg nut securely.

Note.—The foot cannot be turned on the leg when properly secured and if the adapter nut is sufficiently tight the leg will not turn.

- (9) For M20 launchers, force both stock clamps open sufficiently to be slipped on the rear barrel. Do not damage the aluminum tube of the contact lead wire assembly while installing the stock clamps. Pull each clamp together again around the barrel. Be sure that the aluminum tube of the contact lead wire assembly is in the small loop of each clamp. This prevents flattening the tube when tightening the clamp. Before tightening the clamps align the monopod with the trigger grip (parallel with the face of the sight mounting bracket). Insert the screws in the holes of the clamps, put the lock washer on each screw, engage the nuts, and tighten the clamp screws and nuts.
- (10) For M20B1 launchers, make sure that the aluminum tube for the contact lead wire assembly is placed between the two pads on the bottom of the barrel and install the four screws which fasten the stock to the barrel.

52. Maintenance

a. Maintenance consists of cleaning, oiling, and replacing worn or broken parts.

b. Check functioning of monopod; note any binding. Disassemble the group (par. 51*a*). Examine all parts for damage, scores, and burs. Only the keys, screws, and washers are steel. (On M20 launchers the bracket of the front clamp assembly is steel.) Examine these steel parts for rust. Remove rust spots with rifle bore cleaner and crocus cloth.

c. Remove all burs or rough spots with crocus cloth.

Section IX. SIGHTING EQUIPMENT

53. General

a. This section describes reflecting sight assemblies D7313440, D7162890, and D7141999 and contains maintenance instructions and boresighting procedure.

b. The indicators for the reflecting sight are described in paragraph 20. Operation is covered in paragraph 21*d*.

54. Description

a. USE. The reflecting sight assembly together with the elevation plate are used for making elevation settings and estimating leads in sighting the 3.5-inch rocket launcher M20 and M20B1 on a target.

b. ARRANGEMENT. The reflecting sight assembly is a folding type sight in that it can be swung back against the launcher rear barrel so as to be out of the way when the weapon is in carrying position. The reflecting sight, including the indicator arm, pivots in the sight bracket assembly which is on the left side of the rear barrel of the M20 launchers just forward of the monopod. This pivot mounting permits the lens frame and indicator arm to swing as one piece, with the pointer of the indicator arm sweeping a range scale of the elevation plate, and provides the elevation setting of the reflecting sight (par. 20). (On M20B1 launchers the sight bracket assembly is replaced by supports cast integral with the rear barrel.) The folding action

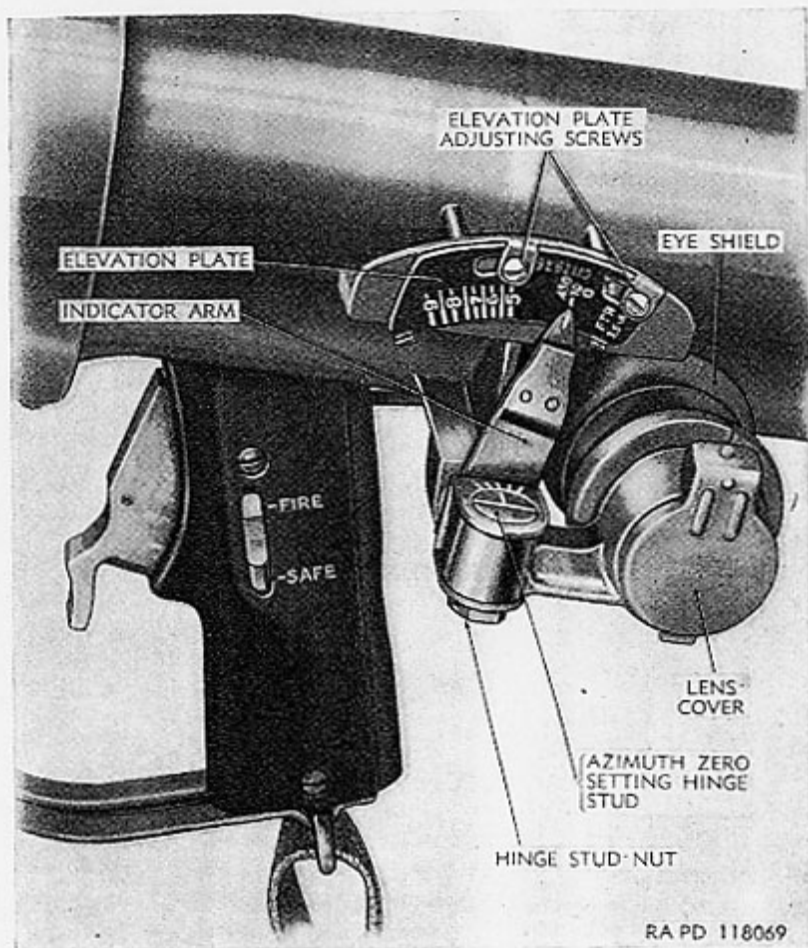

Figure 34. Reflecting Sight Assembly D7141999 (ladder type reticle pattern)—in folded position.

of the sight is provided by a hinge stud which fastens the lens frame into a yoke of the indicator arm. A detent, built into the hinge stud, secures the sight in a fixed firing (sighting) position (figs. 34, 35, and 36) or a fixed carrying position (par. 20c). The indicator arm, pointer, yoke, the hinge stud, the lens cover, the springs, the detent balls, and the elevation plate are steel parts.

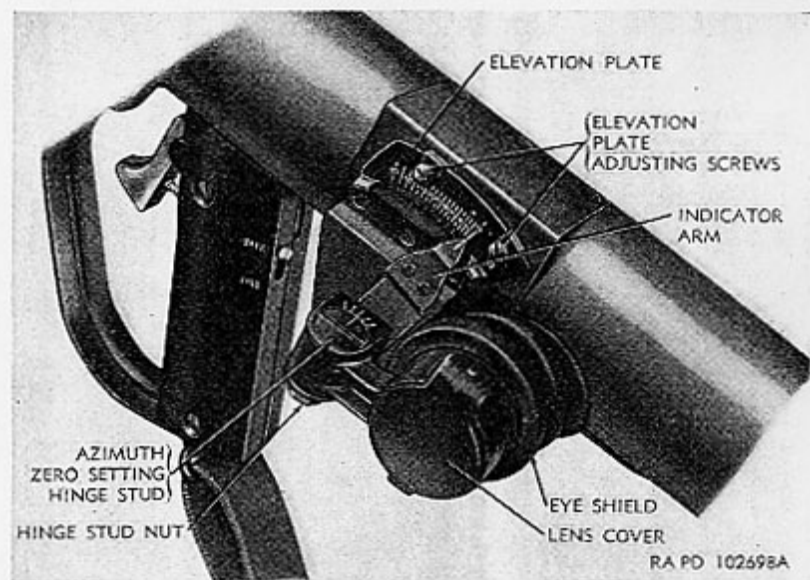

Figure 35. Reflecting Sight Assembly D7162890 (oval reticle pattern) or D7313440 (concentric ring reticle pattern)—in folded position.

c. **LENS COVER.** A lens cover is hinged at the front of the sight. A detent built into the hinge holds the cover open for use of the sight or closed to protect the lens from dust and moisture when the sight is not in use.

d. **EYESHIELD.** A rubber eyeshield affords protection to the gunner's eye against injury by a slight motion of the weapon when it is fired.

e. **RETICLE.** Objects in the field are seen through the optical system of the sight without magnification, while the enlarged image of the reticle is seen in phantom, superimposed on the field. The center of the reticle image is always in the optical axis of the sight.

- (1) *Reflecting sight assembly D7313440 (concentric ring reticle pattern, fig. 37).* This reticle has crossed horizontal and vertical lines and concentric rings so spaced as to represent correct angular leads for a target moving across a line of fire at speeds of 10, 20, 30, and 40 miles per hour. (For example:

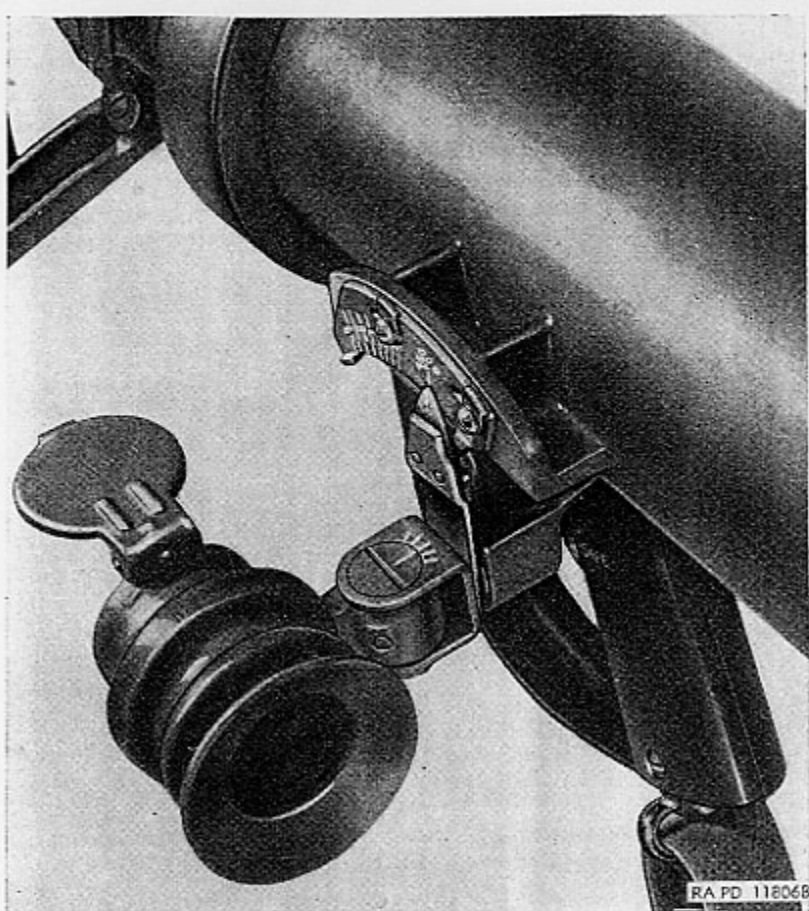
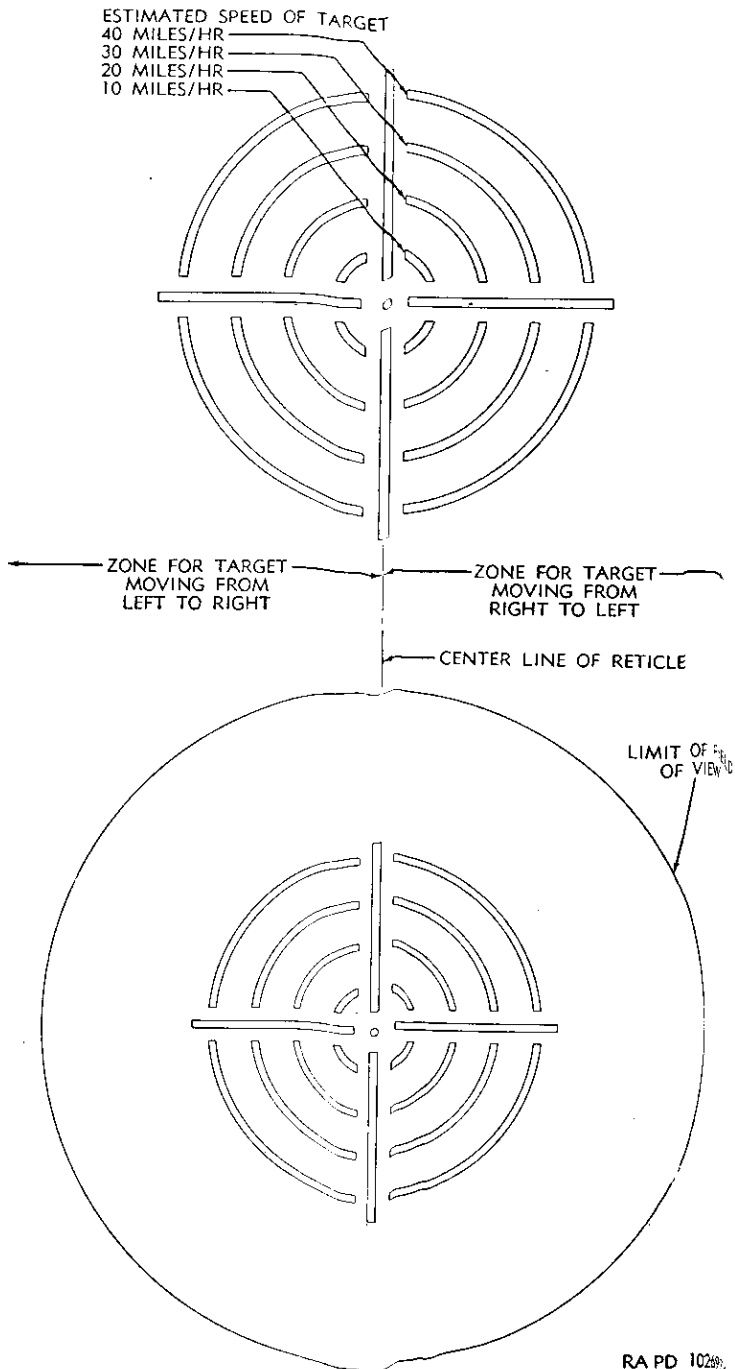

Figure 36. Reflecting Sight Assembly D7141999 (ladder-type reticle pattern)—in firing (sighting) position.

if the target is traveling at an estimated speed of 20 miles per hour from left to right, position the target on the intersection of the horizontal line of sight and the second ring to the left of center.)

- (2) *Reflecting sight assembly D7162890 (elliptical reticle pattern, fig. 38).* This reticle has crossed horizontal and vertical lines and an ellipse with a major axis which coincides with the horizontal line. The vertical center line divides the ellipse in half. Two marks on the horizontal line are spaced a distance equal to $\frac{1}{2}$ the major axis of the ellipse from each other and are equidistant from the center line. Two more marks on the horizontal line are outside of the ellipse, one on each side,



RA PD 10269

Figure 37. Reflecting Sight Assembly D7313440—(concentric ring type) reticle

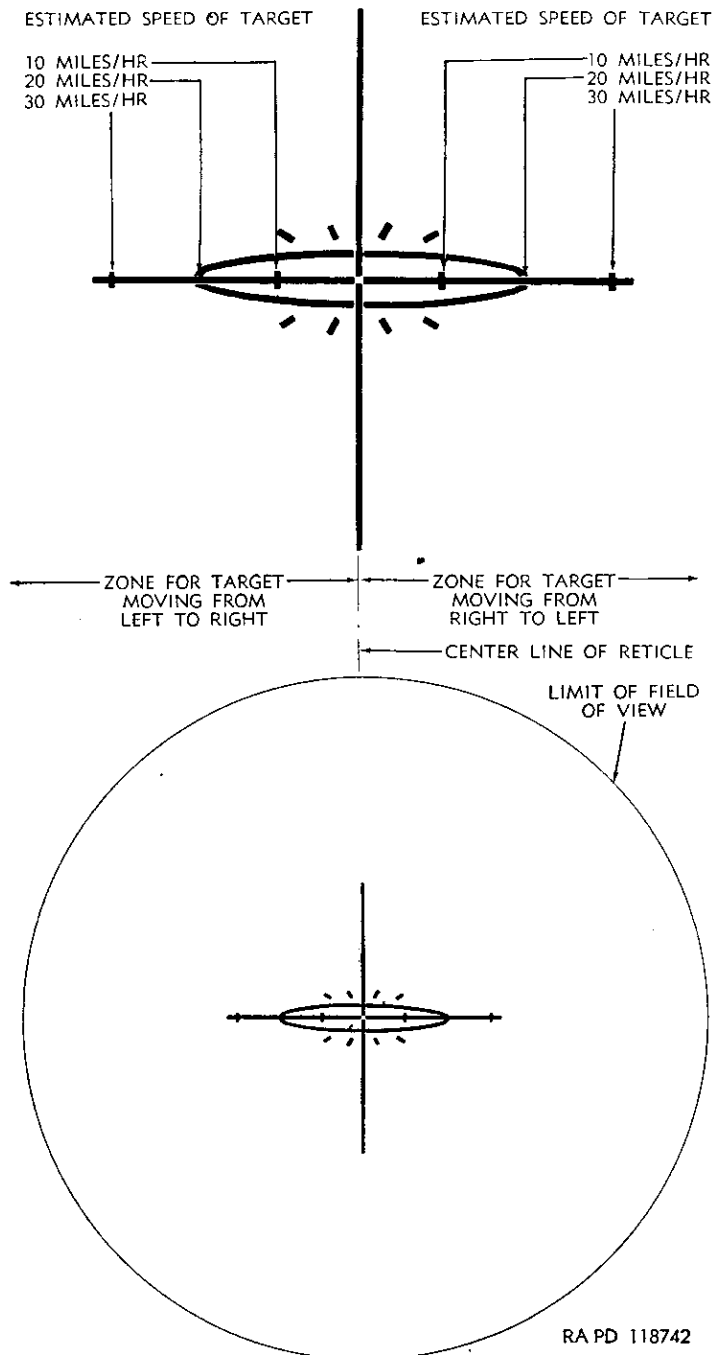

RA PD 118742

Figure 38. Reflecting Sight Assembly D7162890—(oval type) reticle pattern.

and are spaced from the ellipse a distance equal to approximately $\frac{1}{4}$ of the major axis of the ellipse. The horizontal line is therefore divided into 3 equal lengths on each side of the center line. The two marks inside the ellipse represent the ends of the major axis of a smaller indicated ellipse and the two marks outside of the ellipse represent the ends of the major axis of a larger indicated ellipse. The four marks above and the four marks below the ellipse are simply points in the path of the larger indicated ellipse. The smaller indicated ellipse represents the lead required for a target moving at 10 miles per hour, the scribed ellipse indicates the lead required for a target moving at 20 miles per hour, and the larger indicated ellipse represents the lead required for a target moving at 30 miles per hour. The elliptical reticle resembles the concentric ring reticle with the rings flattened for the purpose of more accurately judging the leads required for varying angles of approach. This reticle is used in similar manner to the concentric ring reticle (i. e., the target is positioned on the ellipse which represents the estimated speed of the target). To consider the estimated angle of approach of the target in judging the required lead, visualize a circle centered on the reticle with a diameter equal to the major axis of the ellipse representing the estimated speed of the target. Also visualize a line through the center of the reticle at an angle with the vertical line of the reticle equal to the estimated angle of approach of the target. At the point of intersection of the visualized line and circle, drop a vertical line to the ellipse representing the estimated speed of the target. Position the target at the intersection of this visualized vertical line and the ellipse. Position an approaching target above the horizontal line of the reticle and retreating target below the horizontal line of the reticle. A target moving across the line of fire from left to right is positioned to the left of the vertical centerline of the reticle and a target moving across the line of fire from right to left is positioned to the right of the vertical centerline of the reticle.

Note.—Reflecting sight assemblies D7313440 and D7162890 both use the same elevating plate showing a calibration for every 50 yards range from 0 to 900.

- (3) *Reflecting sight assembly D7141999 (ladder type reticle pattern, fig. 39).* This reticle has a dashed vertical center line, a dashed horizontal normal line, and 4 dashed horizontal range lines. The length of each sector of the vertical center line and the distance between sectors represent 50 yards of range. The length of the sectors of the horizontal lines and

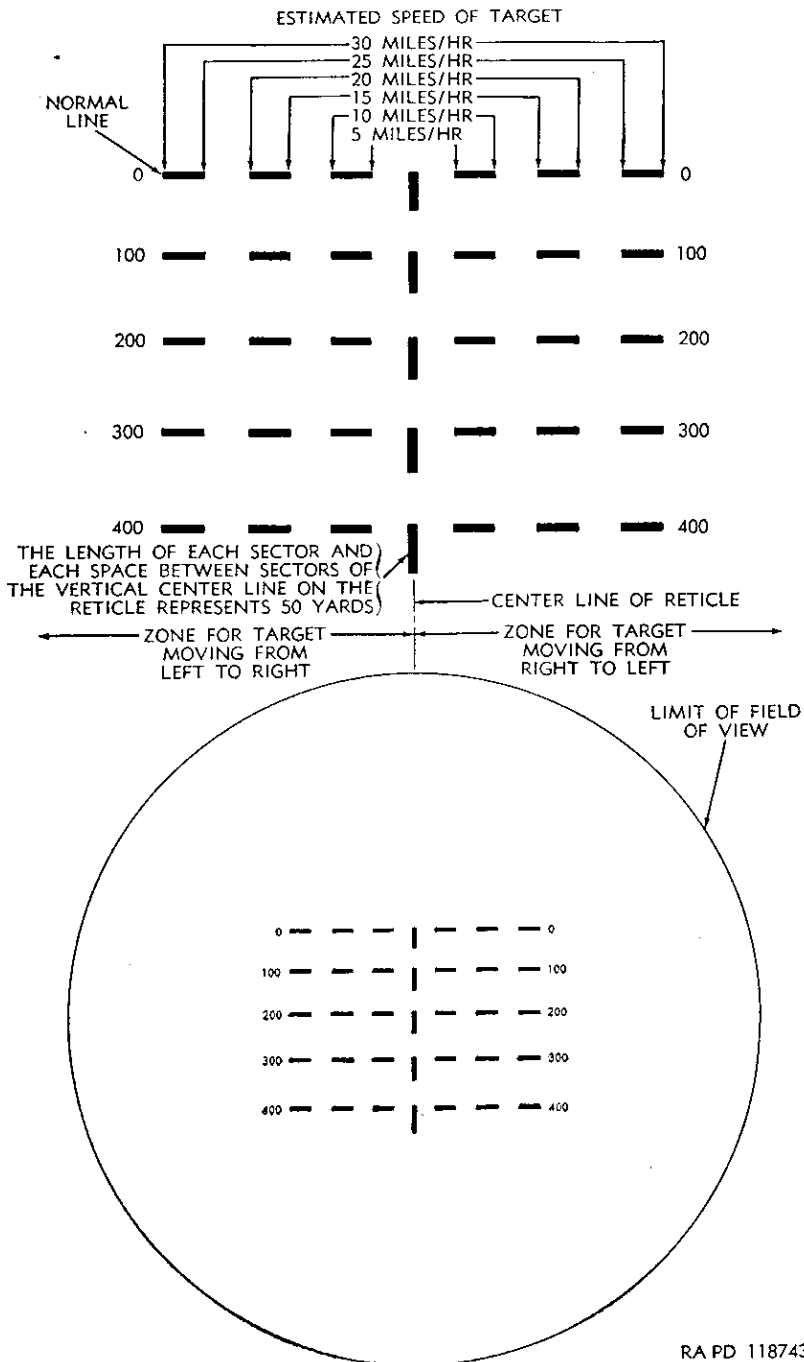

RA PD 118743

Figure 39. Reflecting Sight Assembly D7141999—(ladder type) reticle pattern.

the distance between sectors represent the leads required for various estimated target speeds progressing to right and left of the center line in 5 mile per hour increments. The normal line is marked "0" at each end. The four range lines are each marked to represent the range in yards. The reticle is used as follows:

- (a) If a target is moving from left to right and its speed is estimated at 20 miles per hour with an estimated range of 300 yards, position the target at the left-hand end of the second sector of the 300 yard range line to the left of the vertical center line.
- (b) If the range is estimated as 350 yards, horizontally align the target with the bottom of the sector of the vertical center line just below the 300 yard range line.

Note.—The elevation plate used with reflecting sight assembly D7141999 has no calibrations between "0" and "500" because the ranges from "0" to "450" are indicated on the reticle. Between "500" and "900" the elevation plate is calibrated for each 50 yards of range.

Note.—With the concentric ring (fig. 37) and oval (fig. 38) type reticles, the center of the reticle (i. e., the intersection of the horizontal and vertical lines) covers the spot on the terrain where the rocket will hit (if the range has been estimated correctly). With the ladder type reticle (fig. 39) the intersection of the horizontal reticle line (i. e., normal line or range line) which has been applied to the target with the vertical line of the reticle covers the spot on the terrain at which the rocket will explode (if the range has been estimated correctly).

f. OPERATION. Operation of the sight is described in paragraph 21*d*.

55. Maintenance

a. CARE IN HANDLING SIGHTING INSTRUMENTS.

- (1) Sighting instruments in general are rugged and suited for the designed purpose. However, they will not stand rough handling or abuse. Inaccuracy or malfunctioning will result from mistreatment.
- (2) The lens assembly of the sight is sealed with an atmosphere of nitrogen to prevent fogging. Disassembly of the lens assembly therefore is prohibited, since such disassembly cannot be done without injury to the sight.
- (3) Any instrument which indicates incorrectly or fails to function properly, after the authorized tests and adjustments have been made, are to be turned in for repair by ordnance maintenance personnel. The authorized tests and adjustments are those for which tools and parts have been provided.

Adjustments other than those expressly authorized are not the responsibility of the using arm personnel.

- (4) Painting of sighting equipment by the using arm is *not* permitted.

b. OPTICAL PARTS.

- (1) Keep the exposed surfaces of the lenses and other parts clean and dry. Erosion and etching of the surfaces of the glass, which interferes with vision, can be prevented or greatly retarded by keeping the glass clean and dry. *Keep the lens cover closed at all times when the sight is not in use.*
- (2) Under no circumstances will polishing liquids, pastes, or abrasives be used for polishing lenses.
- (3) For wiping optical parts, use only lens tissue paper, specially intended for cleaning optical glass. Use of cleaning cloth is not permitted. To remove dust, brush the glass lightly with a clean artist's camel's hair brush, and rap the brush against a hard body in order to knock out the small particles of dust that cling to the hairs. Repeat this operation until all dust is removed.
- (4) Exercise particular care to keep optical parts free from oil and grease. Do not wipe the lenses with the fingers. To remove oil and grease from optical surfaces, apply liquid lens cleaning soap with a tuft of lens cleaning tissue paper. If lens cleaning soap is not available, breathe heavily on the glass (provided the temperature of the air is above 32° F.) and wipe off with clean lens tissue paper. Repeat this operation until clean.

56. Adjustment

a. If the vertical (elevation) adjustment of the line of sight is necessary as determined by boresighting procedure (par. 57), loosen the screws at each end of the elevation plate (figs. 34 and 35). Shift the elevation plate forward to lower the line of sight or rearward to raise the line of sight. (Shifting the elevation plate, elevates or depresses the line of sight to the detent action of the indicator arm pointer on the elevation plate.) Tighten the two elevation plate screws after the sight is positioned properly in elevation as determined by the boresighting procedure (par. 57).

b. If lateral (azimuth) adjustment of the line of sight is necessary as determined by the boresighting procedure (par. 57), loosen the hinge stud nut (figs. 34 and 35). Turn the stud by means of the screwdriver slot. This adjusts the position of the detent in the hinge stud and so adjusts the firing (sighting) position of the line of sight

in azimuth (deflection). The graduated markings (fig. 34 and 35) are for reference only. Tighten the hinge stud nut when the sight is properly positioned in azimuth as determined by the boresighting procedure (par. 57).

57. Boresighting

a. GENERAL. The purpose of boresighting is to test the alinement of the sight for parallelism with the bore of the launcher. Normally, bore sight plugs and a testing target are used in boresighting but in emergencies a distant target can be used.

Note.—The launcher must be boresighted after front barrels are changed.

b. TESTING TARGET METHOD. A target must be prepared in accordance with figure 41. The forward and rear bore sight plugs must be improvised in accordance with figure 40.

Note.—The bore sight plugs and testing target are to be improvised by ordnance maintenance personnel.

- (1) Insert the forward bore sight plug (with the cross-hairs) into the bore at the muzzle end of the launcher and the rear bore sight plug (with the peep hole) into the bore at the loading end. Set the launcher in an improvised boresighting stand which holds the launcher firmly in a horizontal position and locate the target $100 \pm \frac{1}{4}$ inches forward of the front edge of the sight mounting bracket. Suspend a plumb bob directly in front of the target. Aline the plumb line on the target (fig. 41) with the cord of the plumb bob.
- (2) Sight through the forward and rear bore sight plugs and aline the center line of the launcher bore accurately on the intersection of the cross on the target. Set the indicator arm at "0" on the elevation plate. Sight through the reflecting sight. The image of the reticle normal line, marked "0," must fall within the horizontal arm of the smaller heavier cross on the target; likewise, the image of the vertical center line on the reticle must aline with the plumb line on the target and must fall within the vertical arm of the smaller, heavier cross on the target.
- (3) If the target cross is not vertically centered, adjust the reflecting sight in elevation as described in paragraph 56*a*. This adjustment is made, as necessary, to bring the image of the horizontal normal line of the reticle on the horizontal arm of the smaller cross on the target.
- (4) If the target cross is not laterally centered, adjust the reflecting sight in azimuth as described in paragraph 56*b*. The image of the vertical center line of the reticle must aline with

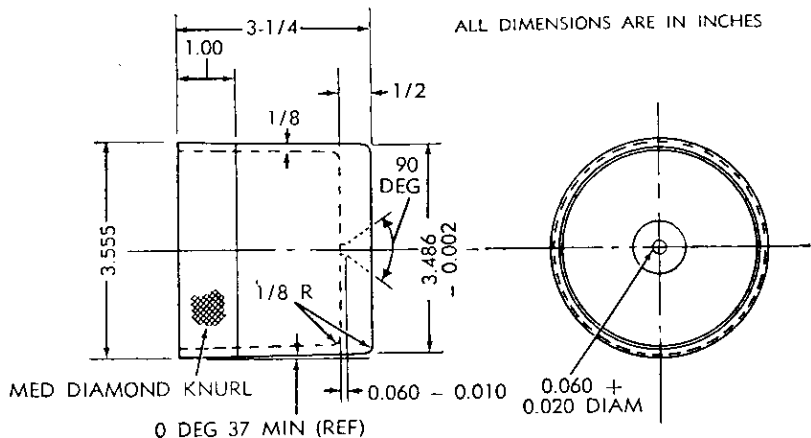

REAR PLUG

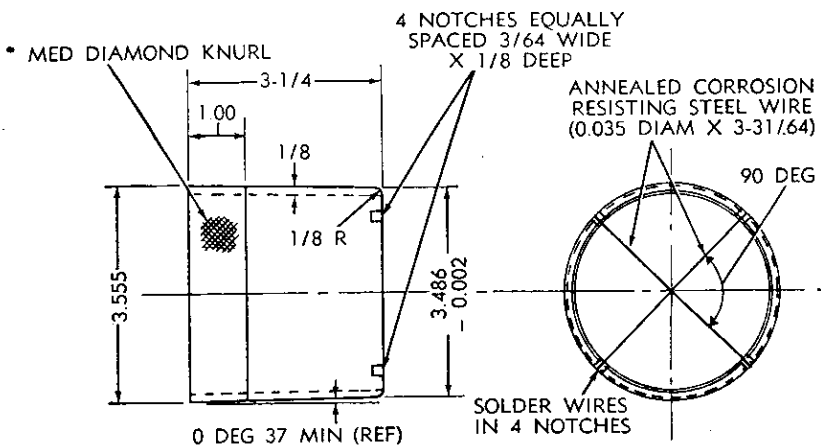

FRONT PLUG

RA PD 114343A

Figure 40. Bore sight plugs for 3.5-inch rocket launcher.

the plumb line of the target and must fall within the vertical arm of the smaller heavier cross on the target.

Note.—Repeat this procedure with the front barrel rotated in the three locking positions. The image of the intersection of the horizontal normal line and the vertical center line of the reticle must fall within the intersection of the horizontal and vertical arms of the target cross for all three locked positions of the front barrel in the rear barrel. It will be necessary to check all three positions after the final adjustment has been made.

c. **DISTANT TARGET METHOD.** If bore sight plugs and testing target are not available, the launcher can be boresighted on a distant target. The greater the distance to the target, the more accurate will be the boresighting.

- (1) The target may be a distant terrain target, 1,500 yards or more from the launcher, or a celestial body. The celestial body may be a star, a point of the crescent moon, or the leading edge of the sun. If the sun is to be used, interpose a filter of smoked glass or darkened photographic negative to reduce glare.

Note.—Due to the motion of celestial bodies relative to earth, it is preferable to use two men so that both sightings can be made simultaneously. No appreciable time must elapse between sighting through the bore of the launcher and through the sight.

- (2) Sight the bore of the launcher on the distant target. Position the eye about 3 feet behind the launcher and in such a position that the outline of the front opening is centered in the outline of the rear opening of the launcher. At the same time the distant target is centered in the outline of the front

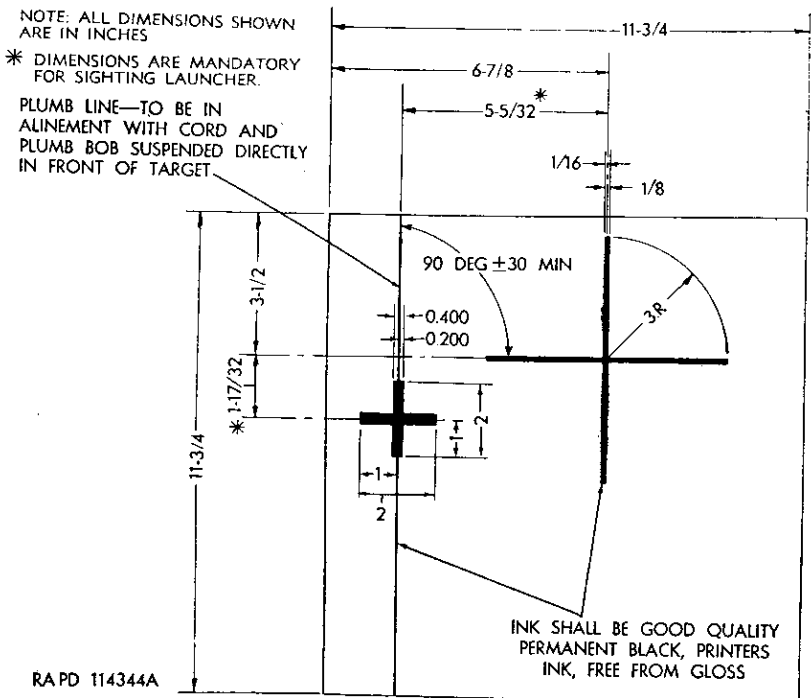

Figure 41. Testing target for 3.5-inch rocket launcher.

opening of the launcher. The launcher must be set firmly in position.

- (3) Set the indicator arm at "0" on the elevation plate. Sight through the reflecting sight. Make the adjustments described in paragraph 56 to bring the image of the intersection of the horizontal, normal line and the vertical center line of the reticle within the intersection of the horizontal and vertical arms of the target cross.

Note.—The normal line of the reticles of reflecting sight assemblies D7313440 (concentric ring reticle pattern, fig. 37) and D7162890 (elliptical reticle pattern, fig. 38) is the horizontal line of these reticles. The normal line of the reticle of reflecting sight assembly D7141999 (ladder type reticle pattern, fig. 39) is the horizontal line marked "0" at each end.

58. Repairs

Note.—The following maintenance and repair of the sight may be performed only by ordnance maintenance personnel.

a. If the lens cover does not function properly, remove the lens cover screws, lens cover, and lens cover ball spring and ball. Replace the spring and reassemble the lens cover (figs. 34 and 35).

b. If positioning of the sight between carrying and firing positions does not operate properly, remove the nut and washer from the hinge stud. Drive out hinge stud by tapping it lightly. Take care not to lose spring, ball, and seat. Replace defective spring and reassemble.

- (1) Place the sight in the yoke of the indicator arm so as to align the holes.
- (2) Assemble the spring, seat, and ball in the hinge stud. Insert the hinge stud with the flat towards the launcher and install the lock washer and nut on the hinge stud. Tighten the nut.
- (3) Boresighting will be necessary after this repair.

c. If the lens assembly or indicator arm become damaged, the reflecting sight must be replaced.

- (1) Unscrew the two screws in the slots of the elevation plate and remove the screws, elevation plate washers, and lock washers. This frees the elevation plate.
- (2) Unscrew the sight and indicator arm counterclockwise. It will be necessary, for the first few turns, to press the pointer up slightly to clear the sight bracket or support.
- (3) Install the new reflecting sight by engaging the indicator arm stud in its tapped hole. *This is a fine thread and care must be exercised not to cross the thread.* Turn the indicator arm clockwise to the end of the thread; then back off on the thread

sufficiently to permit the indicator arm to point to the extreme right of the elevation plate. It will be necessary, for the last few turns, to raise the pointer slightly for clearance.

- (4) Lift the pointer enough to slip the elevation plate under it. With the elevation plate washers and lock washers on the screws, insert the two elevation plate screws through the slots in the elevation plate and engage the tapped holes in the sight bracket or support. Tighten the screws.
- (5) Boresighting will be necessary after this repair.

CHAPTER 4

AUXILIARY EQUIPMENT

Section I. GENERAL

59. Scope

Chapter 4 contains information pertaining to the rockets used in conjunction with the 3.5-inch rocket launchers M20 and M20B1.

Section II. AMMUNITION

60. General

Rocket ammunition for the 3.5-inch rocket launcher M20, M20 modified, and M20B1 is issued in the form of fixed complete rounds (fig. 42). The term "fixed" signifies that the propelling charge is not adjustable and that the round is loaded into the launcher as a unit. The complete round consists of a rocket head, a fuze, a rocket motor which contains the propellant and its igniter, and a fin assembly which is rigidly attached to the rear of the motor. The fuze body, threaded at both ends, serves also as a coupling for the rocket head and motor.

61. Classification

a. Ammunition for this rocket launcher consists of the following types which are classified according to the rocket head as high-explosive antitank (HE, AT) and practice. The same motor is used for both types.

b. High-explosive antitank rocket heads are thin-walled and contain a relatively large shaped charge of high explosive especially designed for penetrating armored targets.

c. Practice heads used for training purposes are completely inert. They are of the same size, shape, and weight as the HE, AT head.

62. Identification

a. GENERAL. Ammunition and ammunition components are completely identified by the painting and marking (including an ammunition lot number) which appears on all original packing containers and, when practicable, on the item itself.

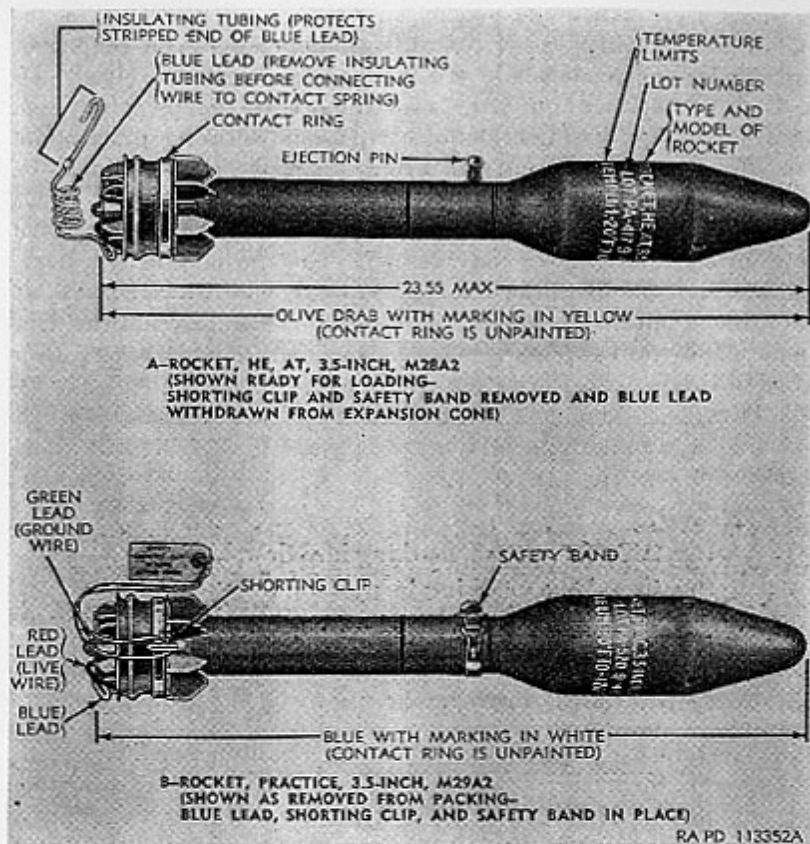

Figure 42. 3.5-inch rockets.

b. MODEL. To identify a particular design, a model designation is assigned at the time the design is classified as an adopted type. This model designation becomes an essential part of the item's standard nomenclature and is included in the marking on the item. The present system of designating the model is to use the letter "M" followed by an arabic numeral. Modifications are indicated by adding the letter "A" and the appropriate arabic numeral. Thus, "M100A1" would signify the first modification for an item for which the original model designation was "M100."

c. AMMUNITION LOT NUMBER. At the time of manufacture, every item of ammunition is assigned a lot number in accordance with pertinent specifications. When practicable, this lot number is stamped on the item itself. In addition, an ammunition lot number is assigned to the complete rounds. The ammunition lot number is stamped

or marked on each round and on all packing containers. It is required for all purposes of record, including reports on condition, functioning, and accidents in which the ammunition is involved. To provide for the most uniform functioning, fixed rounds of any one lot are made up of single lots of components whenever practicable. For the greatest uniformity in firing, successive rounds should be from the same ammunition lot.

d. MARKING. Standard markings are stenciled on the rocket in the appropriate color (fig. 42 and *e* below). They include the type, size, and model of the item; the ammunition lot number which consists of the loader's initials or symbol, the loader's lot number, and the date (month and year) of loading; and the temperature limitations within which it is safe to fire the rocket.

e. PAINTING. Ammunition is painted to prevent rust and to provide, by the color, a means of identifying each type. Rockets are painted as follows:

HEAD:

HE, AT—Olive drab, marking in yellow.

Practice—Blue, marking in white.

MOTOR: HE, AT and practice—Olive drab.

63. Care, Handling, and Preservation

a. Ammunition is packed to withstand conditions ordinarily encountered in the field. Care must be observed to keep packings from being broken or damaged. All broken packings must be repaired immediately and careful attention given to the transfer of all markings from the old to the new parts. When it is necessary to leave ammunition in the open, raise it on dunnage at least 6 inches from the ground and cover it with a double thickness of tarpaulin, leaving enough space for circulation of air. Suitable trenches should be dug to prevent water from running under the pile.

b. Since explosives are adversely affected by moisture and high temperatures, due consideration should be given to the following:

- (1) Do not break the moisture-resistant seal until ammunition is to be used. Ammunition removed from an airtight container, particularly in warm damp climates, is subject to accelerated corrosion and deterioration, thereby causing the ammunition to become unserviceable.
- (2) Protect the ammunition from sources of high temperature including the direct rays of the sun. Rockets should never be stored where the temperatures may exceed 120° F.

c. Rockets must not be disassembled.

d. Rockets should be protected from mud, sand, dirt, and water. If rounds become dirty or wet, they should be wiped off at once with a clean, dry, wiping cloth.

e. *Explosive ammunition must be handled with appropriate care at all times. The explosive elements in igniters and fuzes are particularly sensitive to undue shock and high temperatures. Boxes containing ammunition should not be dropped, thrown, tumbled, or dragged.*

f. In handling and storage, complete rounds should at all times be kept pointed in that direction which would result in the least damage should the propellant be accidentally ignited.

g. Rounds prepared for firing, but not fired, will be returned to their original condition and packings, and appropriately marked. Such ammunition will be used first in subsequent firings so that stocks of opened packages may be kept to a minimum.

h. Do not handle duds. Because their fuzes are armed, and hence extremely dangerous, duds will not be moved or touched, but will be destroyed in place in accordance with TM 9-1900.

64. Authorized Rounds

a. GENERAL. Ammunition authorized for use in the 3.5-inch rocket launchers M20 and M20B1 is listed in table I. Standard nomenclature, used in the listing, completely identifies each item except for the lot number.

b. ROCKET HEAD.

- (1) The HE, AT rocket head M28, M28A1, and M28A2, consists of a thin gage steel body cylindrical in shape and tapered at the rear—the cylindrical portion is 3.5 inches in diameter, the rear of the tapered portion, approximately 2 inches. The body contains a shaped charge of 1.93 pounds of COMP B held in place by a thin gage metal cone. The forward end of the body is closed by a thin gage metal ogive. The weight of the complete head is approximately 4.5 pounds.
- (2) The practice rocket head M29, M29A1, and M29A2 consists of a hollow cast iron body of the same external dimensions as the HE, AT head. The forward end is closed by a thin gage metal ogive similar to that fitted to the HE, AT head. The weight of the complete head is approximately 4.65 pounds—the weight of the cast iron body compensating for the absence of a filler. An alternative head consists of the metal parts of the HE, AT rocket head and an inert filler to bring the weight up to that of cast iron practice head.

Table I.—Authorized ammunition

Standard nomenclature of complete round	Complete round		Rocket head			Rocket motor			Fuze	
	Length (in)	Weight (lb)	Type of filler	Kind of filler	Weight of filler (lb)	Model of igniter	Model of propellant	Weight of propellant (lb)	Standard nomenclature	Action
ROCKET, HE, AT, 3.5-inch, M28 (T80E2).	23.55	8.90	HE	COMP B	1.93	M20 (T18)	M7	0.36	FUZE, rocket, BD, M404 (T160E6).	Nondelay.
ROCKET, HE, AT, 3.5-inch, M28A1.	23.55	8.90	HE	COMP B	1.93	M20 (T18)	M7	.36	FUZE, rocket, BD, M404 (T160E6).	Nondelay.
ROCKET, HE, AT, 3.5-inch, M28A2.	23.55	8.90	HE	COMP B	1.93	M20 (T18)	M7	.36	FUZE, rocket, BD, M404 (T160E6).	Nondelay
ROCKET, practice, 3.5-inch, M29 (T85E2).	23.55	8.90	None*	None*	-----	M20 (T18)	M7	.36	FUZE, rocket, dummy, M405 (T2008E2).	Inert.
ROCKET, practice, 3.5-inch, M29A1.	23.55	8.90	None*	None*	-----	M20 (T18)	M7	.36	FUZE, rocket, dummy, M405 (T2008E2).	Inert.
ROCKET, practice, 3.5-inch, M29A2.	23.55	8.90	None*	None*	-----	M20 (T18)	M7	.36	FUZE, rocket, dummy, M405 (T2008E2).	Inert.

*Head consists of cast iron body with steel ogive and no filler. An alternative head consists of steel body and ogive, inert loaded to weight.

- (1) *Description.* The rocket motor assembly consists of the propellant and igniter housed in a metal tube to which the fin assembly is securely attached. The front end of the tube is assembled to the base of the fuze—the rear end is constricted to form a nozzle. The cylindrical motor cavity is divided into four sections by two axial spacer plates set at right angles to each other. The rear ends of the spacer plates rest against the trap. The same motor is used for both the HE, AT, and practice rockets, although there are some differences in the motors assembled to rockets of different modifications. The principal differences are in the trap, fin, and contact ring assembly, as indicated below. The trap in the M28 and M29 rockets is a cast steel grid whereas that in the later modifications is a steel disk with drilled holes.
- (2) *Propellent.* The propelling charge consists of 12 grains of the M7 propellent. Each grain is 5 inches long and approximately $\frac{3}{8}$ inch in diameter and weighs 0.03 pound. Three grains are placed in each of the four sections (a total of 12 grains—0.36 pound—of propellent) formed by the spacer plates. Each lot of propellent is adjusted at the time of manufacture to give standard velocity. Since the rate of burning increases with the initial temperature, it is important not to fire rockets at temperatures beyond the limits marked on each rocket. Firing at temperatures below the minimum (-20° F.) will give erratic ranges and excessive back blast of powder particles; firing at temperatures above the maximum ($+120^{\circ}$ F.) will cause dangerous pressures to build up within the motor. The propellent is ignited by the igniter M20 ((3) below).
- (3) *Igniter and leads.* The igniter M20 (T18), which consists of a short, cylindrical, plastic case containing a 3-gram black powder charge and SQUIB, electric, M1, is assembled in the forward end of the motor on top of the propellent spacer plates. The leads of the electric squib, running parallel to the grains of propellent, pass from the igniter through the nozzle closure into the expansion cone ((4) below). The green lead (ground wire) is connected to the support ring of the contact ring assembly ((4) below). The red lead (live wire) is connected to the contact ring by a tubular rivet which passes through but is insulated from the support ring. These connections are positioned 180° apart. The blue lead ("pig-tail") is actually an extension of the live wire (fig. 42) and, as such, has one end connected to the same terminal as the red

lead—the free end being connected, at the time of loading, to one of the contact springs on the launcher contact spring clamp. The blue lead is coiled and placed in the expansion cone during shipment—it is held in this position by a piece of adhesive tape. The free end of the pigtail is stripped and then covered with a piece of plastic tubing which insulates the stripped end during handling and shipping—this insulating tubing is removed just prior to connecting the blue lead to the contact spring.

- (4) *Fin assembly.* The fin assembly for each model of rocket consists of an aluminum-alloy expansion cone, three pairs of aluminum-alloy fins (6 fins) and a contact ring assembly. The contact ring assembly, which encircles the fins, consists of three rings: Innermost is the aluminum support ring which is separated from the cadmium-plated copper contact ring (outer ring) by a laminated plastic insulating ring. The fins are spot welded to the expansion cone and the expansion cone is press-fitted to the rear end of the motor tube. On the M28A2 and M29A2 rockets (fig. 42) the contact ring assembly is 1.78 inches wide and the groove in the support ring for engagement with the latch mechanism of the launcher is to the rear of the contact ring, whereas for the other modifications the contact ring assembly is 1.04 inches wide and the groove is forward of the contact ring.

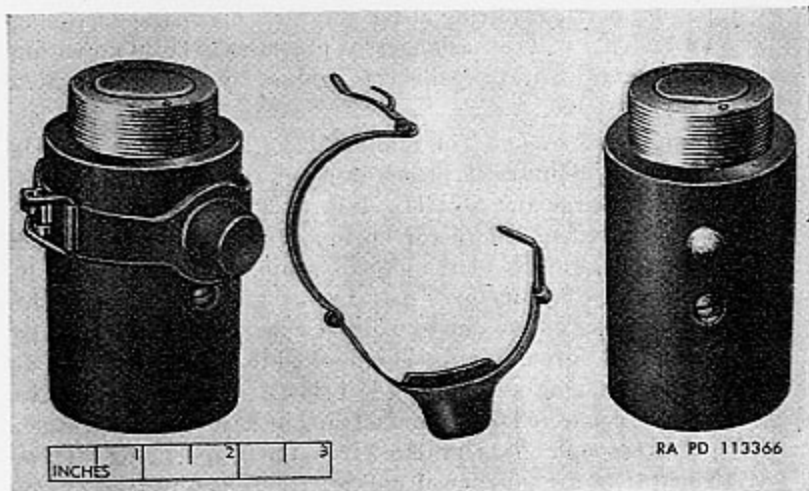

Figure 43. Fuze, Rocket, BD, M404 (T160E6).

- (1) *Description.* This base-detonating fuze (figs. 42 and 43) is of the simple inertia type which functions with nondelay action upon impact. The fuze body and safety band are olive drab; the fuze nomenclature, the loader's lot number, and the month and year of loading are stamped into the metal. An ejection pin, which passes through the fuze body and prevents movement of the internal parts, is provided to preclude accidental functioning during shipping, handling, and firing. An additional safety feature is provided by the safety band which prevents the ejection pin from moving during shipping and handling. The safety band is not removed from the fuze until the rocket head has been loaded into the launcher. The fuze mechanism consists of a plunger, an actuating sleeve, a firing pin, a setback sleeve, a creep spring, a stop pin, and a lock pin. The explosive train includes a detonator and booster.
- (2) *Functioning.* When the safety band is removed, the ejection pin moves outward approximately $\frac{3}{8}$ inch but still prevents all parts of the fuze mechanism from moving. When the rocket is fully seated, the ejection pin is partially depressed by the launcher thereby freeing the setback sleeve so that it can move on setback. It should be noted that in this condition the fuze is still safe since the ejection pin prevents movement of the actuating sleeve and firing pin. If it becomes necessary to remove the rocket from the launcher, the ejection pin will move outward and reengage the setback sleeve thus returning the fuze to its original safe condition. When the rocket is fired, the force of setback opposing the action of the creep spring moves the setback sleeve to its rearward position where it is held by the lock pin. When the rocket leaves the muzzle of the launcher the ejection pin is thrown clear of the fuze, and the fuze is fully armed. During flight, the firing pin spring prevents the firing pin from striking the detonator, and the creep spring retards forward movement of the plunger and actuating sleeve. The action of the creep spring is strong enough to retard the plunger and actuating sleeve and to prevent the fuze from firing should the rocket strike a light object such as light brush or undergrowth. Upon impact with a more resistant object the plunger and actuating sleeve move forward—the sleeve hits the firing pin lever causing the firing pin to strike the detonator and explode the rocket.

e. FUZE, ROCKET, DUMMY, M405 (T2008E2). The M405, used for practice purposes, is an inert fuze which incorporates an ejection pin assembly simulating that used in the BD fuze M404 (T160E6) (*d* above). The body of the fuze and the safety band are painted blue. The fuze nomenclature, the loader's lot number, and the month and year of loading are stamped into the metal.

65. Preparation for Firing

a. After the rocket is removed from its packing, the rocket is prepared for firing as follows:

- (1) Remove the shorting clip (fig. 42) from the contact ring assembly before loading rocket into launcher.
- (2) Insert rocket head into launcher, then remove the safety band from fuze.
- (3) Seat rocket fully so that latch engages the notch in the fins.
- (4) With the launcher set at SAFE, the blue lead is withdrawn from the expansion cone, uncoiled, and the insulating tubing removed from the stripped end.
- (5) Connect stripped end of wire to one of the two contact springs on the launcher, whichever is the more convenient.

b. For rockets prepared for firing but not fired, the launcher will be unloaded as follows:

- (1) Set the launcher at SAFE.
- (2) Disconnect blue lead from contact spring.
- (3) Insulate the stripped end of blue lead, coil the lead and replace it in the expansion cone. Tape the blue lead to the expansion cone.
- (4) Disengage the latch from the groove in the support ring and carefully withdraw the rocket from the launcher until the fuze is exposed.
- (5) Replace the shorting clip on contact ring assembly.
- (6) Replace safety band on fuze.
- (7) Remove rocket from launcher.
- (8) Restore rocket to its original condition and packing.

66. Precautions in Firing

The following will be observed in order to prevent injury to personnel and damage to matériel:

a. If a rocket fails to fire and examination shows the launcher is not at fault, the safety band and shorting clip will be replaced and the rocket set aside for destruction by qualified personnel.

b. In firing rockets, consideration should be given to the blast of flame to the rear. Ammunition and personnel should be kept out

of the blast area (par. 22a). The loader should exercise particular care to stand clear of the blast.

c. Do not fire rockets at temperatures below -20° F or above $+120^{\circ}$ F which are specified as the safe limits for each round (par. 64c (2)).

d. Rockets with damaged fins should not be fired since they are unstable in flight, hence erratic in range and deflection. Be careful when loading rockets into the launcher to prevent damage to blades of the fin assembly.

e. When firing from wooded areas or other cover, exercise care to prevent the rocket from striking branches or other objects which might deflect the rocket or even cause accidental functioning.

67. Packing

Rockets of this caliber are packed in individual, hermetically sealed, metal containers which, in turn, are packed in wooden boxes (fig. 44) in quantities of three containers (three rockets) per box. The exterior of the metal containers are painted to indicate the type of rocket contained, that is, olive drab with yellow marking for the HE, AT rockets and blue with white marking for the practice rockets. The marking on the container includes an AIC symbol, nomenclature of the packed item, and ammunition lot number. The over-all dimensions of the packing box are approximately $29\frac{5}{8}$ inches long, $14\frac{1}{8}$ inches wide and $6\frac{5}{8}$ inches high. The total weight is 53 pounds and its displacement is 1.59 cubic feet. For more complete packing and shipping data see Department of the Army Supply Catalog ORD 3 SNL S-9 (now published as ORD 11 SNL S-9).

NOTE: IN ADDITION TO THE MARKING SHOWN, THE CLEATS OF BOXES CONTAINING PRACTICE AMMUNITION ARE PAINTED BLUE AND A BLUE STRIPE, 3 INCHES WIDE, IS PAINTED AROUND THE CENTER OF THE BOX IN THE POSITION INDICATED BY BROKEN LINES

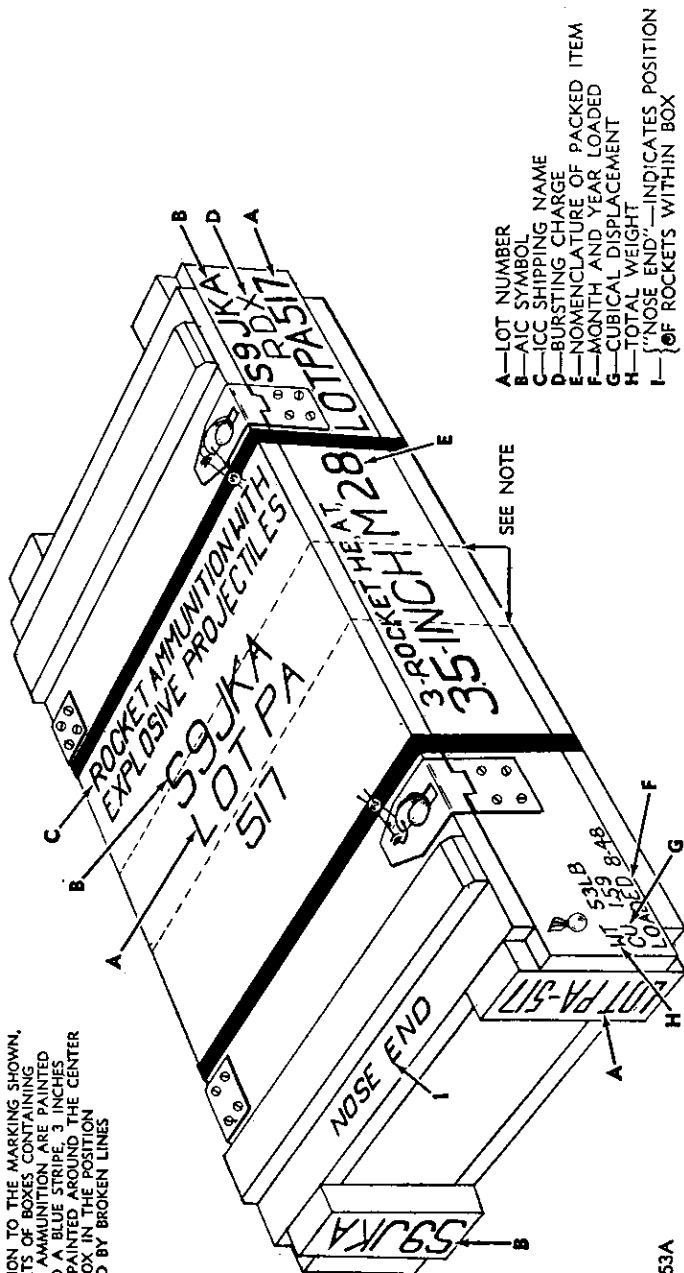

Figure 44. Packing box for 3.5-inch rockets.

CHAPTER 5

MAINTENANCE EQUIPMENT

Section I. GENERAL

68. Scope

This chapter contains information on parts, special tools, and equipment for field and depot maintenance. It includes a description of the use of the firing mechanism electrical output tester and such assembly and disassembly of the launcher as is incidental to the use of the tester.

Note.—The firing mechanism electrical output tester is not issued to the using arm. It is issued only to ordnance field and depot maintenance organizations.

Section II. PARTS, SPECIAL TOOLS, AND EQUIPMENT FOR FIELD AND DEPOT MAINTENANCE

69. General

Tools and equipment and maintenance parts over and above those available to the using organization are supplied to ordnance field maintenance units and depot shops for maintaining, repairing, and/or rebuilding the matériel.

70. Parts

Maintenance parts will be listed in Department of the Army Supply Catalog ORD 8 SNL B-42, which is the authority for requisitioning replacements. Parts not listed in an ORD 8 catalog but required by depot shops in rebuild operation may be requisitioned from the listing in the corresponding ORD 9 catalog and will be supplied if available.

71. Special Tools and Equipment

The special tools and equipment tabulated in table II are listed in Department of the Army Supply Catalog ORD 6 SNL B-20. This tabulation contains only those special tools and equipment necessary to perform the operations described in this manual, is included for information only, and is not to be used as a basis for requisitions.

Table II.—Special tools and equipment for field and depot maintenance

Item	Identifying No.	References		Use
		Fig.	Par.	
TESTER, elec output, firing mechanism, rocket launcher, range 0-100 milliwatt seconds, w/case.	7142254			Used to test the electrical firing mechanism B7140325.
or TESTER, elec output, firing mechanism, rocket launcher, range 0-50 milliwatt seconds, w/case.	17-T-5518-100			Used to test the electrical firing mechanism C7313326.

Section III. FIRING MECHANISM ELECTRICAL OUTPUT TESTER

72. General

A firing mechanism electrical output tester is used to determine the serviceability of the firing mechanism and electrical circuit of 3.5-inch rocket launchers M20 and M20B1. Fastened to the terminals of the tester are two wire leads of the clip-on type. These wire leads will be connected to the launcher for testing purposes as stated in the following paragraph 73. The firing mechanism C7313326 (single action-fig. 7), firing mechanism B7140325 (double action-fig. 7), and respective electrical circuits are serviceable when the tester shows a minimum reading of 15 milliwatt seconds for a rebuilt weapon or a weapon in use in the field. The minimum reading of 15 milliwatt seconds has been increased from 14 milliwatt seconds specified in previous instructions in order to allow for error in existing testers.

Note.—The testing of the firing mechanism with the electrical output tester is to be performed only by ordnance maintenance personnel.

Caution: Do not use firing mechanism electrical output tester 17-T-5518-100 for testing electric firing mechanism B7140325 as the output of this firing mechanism is beyond the capacity of this tester and will burn out its thermocouple. The firing mechanism electrical output tester 7142254, calibrated from 0 to 100 milliwatt seconds, must be used.

73. Instructions for Use of Tester

a. To test the electrical circuit of the launcher when completely assembled, proceed as follows:

- (1) Place the launcher on a bench.

- (2) Attach clip end of one wire lead from the tester to contactor latch at the rear of the tube. Scrape paint, corrosion, or foreign matter from latch to insure good connection.
- (3) Attach clip end of remaining wire lead to contact spring stud located near the rear of tube. Make certain that the clip attached to the stud is not grounded on the rear barrel of the launcher. Scrape paint, corrosion, or foreign matter from the stud to insure good connection.
- (4) Operate the firing mechanism by squeezing the trigger.
- (5) Note the maximum reading on the tester.

b. To test only the firing mechanism C7313326 (single action—fig. 7) when assembled to the launcher, proceed as follows:

- (1) Remove the grips (par. 48*a*).
- (2) Attach slip end of one wire lead from tester to firing mechanism rear plate. (Preferably to the bracket of the rear plate and bracket assembly.)
- (3) Attach clip end of remaining wire lead to the lug of the terminal located on firing mechanism rear plate assembly, being certain that this clip is not grounded.
- (4) Operate the firing mechanism by squeezing the trigger. Do *not* release trigger immediately.
- (5) Note the maximum reading on the tester.

c. To test only the firing mechanism B7140325 (double action—fig. 7) when assembled to the launcher proceed as follows:

- (1) Remove the grips (par. 48*b*).
- (2) Attach clip end of one wide lead from tester to firing mechanism bottom plate. (Preferably to the bracket of the bottom plate and bracket assembly.)
- (3) Attach clip end of remaining wire lead to the lead from the field coil, being certain that this clip is not grounded.
- (4) Operate the firing mechanism by squeezing the trigger.
- (5) Note the maximum reading on the tester.

d. To test the electrical firing mechanism group assembly when disassembled from the launcher (par. 48*a* (1) and *b* (1) for disassembly), proceed as follows:

- (1) Attach clip end of one wire lead from tester to support bracket of the firing mechanism rear or bottom plate assembly. Scrape paint, corrosion, or foreign matter from bracket to insure good connection.
- (2) Attach clip end of remaining wire lead to the lead from the field coil.
- (3) Operate the firing mechanism by squeezing the trigger. (With firing mechanism C7313326, do not release the trigger

FIRING MECHANISM ELECTRICAL
OUTPUT TESTER-17-T-5518-100

FIRING MECHANISM BRACKET

TRIGGER
ROCKER
ARM TOGGLE
PIN HOLE

WIRE LEAD FROM
FIRING MECHANISM

ELECTRICAL FIRING
MECHANISM GROUP ASSEMBLY

WIRE LEAD FROM TESTER

RA PD 113852

Figure 45. Testing the electrical firing mechanism group assembly C7313326 (single action).

immediately.) The firing mechanism should be operated at least 10 times before retesting with the tester.

e. The power output in the tests outlined above should be as follows:

- (1) *Firing mechanism C7313326 (single action—fig. 7).* With this firing mechanism the power output must test 15 milliwatt seconds or more. If a low reading is obtained, a few drops of oil will be introduced into the rocker arm cover through the hole for the rocker arm toggle pin. The firing mechanism then should be operated at least 10 times before retesting with the tester.
- (2) *Firing mechanism B7140325 (double action—fig. 7).* With this firing mechanism the power output must test 15 milliwatt seconds or more. If a low reading is obtained, adjust firing mechanism (par. 48b(2)) and lubricate (par. 35e) the firing mechanism. Always operate the firing mechanism at least 10 times before retesting with the tester.

Note.—The firing mechanism electrical output tester for testing firing mechanism C7313326 (single action—fig. 7) is calibrated from 0 to 50 milliwatt seconds. The firing mechanism electrical output tester for testing firing mechanism B7140325 (double action—fig. 7) is calibrated from 0 to 100 milliwatt seconds. A meter calibrated from 0 to 50 milliwatt seconds must not be used with firing mechanism B7140325 (double action—fig. 7).

Caution: When the grips are removed from the electrical firing mechanism the magnetic field tends to pick up metal particles; therefore, work space will be kept as clean as possible.

f. When using the tester, be sure the indicating needle is at zero before squeezing the firing mechanism trigger.

- (1) With firing mechanism C7313326 (single action—fig. 7) permit the indicating needle of the test meter to travel to its maximum register on the scale before releasing the trigger.
- (2) With firing mechanism B7140325 (double action—fig. 7), releasing the trigger has no effect whatever on the needle of the testing meter.

g. In reassembling the grips of firing mechanism C7313326 (single action—fig. 7), make sure that the safety switch is correctly assembled. Place the safety in the left grip with the tapered part of the switch contact upward.

CHAPTER 6

SHIPMENT AND LIMITED STORAGE AND DESTRUCTION TO PREVENT ENEMY USE

Section I. SHIPMENT AND LIMITED STORAGE

74. Domestic Shipping Instructions

a. PREPARATION. When shipping the 3.5-inch rocket launchers interstate or within the zone of interior, the officer in charge of preparing the shipment *will be responsible* for furnishing launchers to the carriers for transport in a serviceable condition, properly cleaned, preserved, packaged and packed as prescribed in paragraph 76.

Caution: Personnel withdrawing launchers from a limited storage status for domestic shipment must not remove preservatives other than to insure that launchers are complete and serviceable, in which case the preservatives must be restored. The removal of preservatives is the responsibility of depots, ports, or field installations (posts, camps, and stations) receiving the shipments.

b. ARMY SHIPPING DOCUMENTS. Prepare all Army shipping documents accompanying freight in accordance with TM 38-705.

Note.—For loading and blocking boxed matériel in boxcars refer to TM 9-2854.

75. Limited Storage Instructions

a. GENERAL.

- (1) Launchers received already processed for domestic shipment need not be reprocessed unless the inspection performed reveals corrosion, deterioration, etc.
- (2) Completely process launchers if inspection reveals that they have been rendered ineffective by operation, freight shipping damage, or upon receipt of launchers directly from manufacturing facilities.
- (3) Launchers to be prepared for limited storage must be inspected as prescribed in SB 9-65, and processed in accordance with paragraph 76.

b. RECEIVING INSPECTIONS.

- (1) Report of launchers received in a damaged condition or improperly prepared for shipment will be reported on DD Form 6 in accordance with SR 745-45-5.
- (2) When launchers are inactivated, they are to be placed in a limited storage status for periods not to exceed 90 days. Stand-by storage for periods in excess of 90 days will normally be handled by ordnance maintenance personnel only.
- (3) Immediately upon receipt of launchers they must be inspected and serviced as prescribed in section II, chapter 2. Perform a systematic inspection and replace or repair all missing or broken parts. If repairs are beyond the scope of the unit and the launchers will be out of service for an appreciable length of time, place launchers in a limited storage status and attach a tag to the launchers specifying the repairs needed. The report of these conditions will be submitted by the unit commander for action by an ordnance maintenance unit.

c. INSPECTIONS DURING STORAGE. Perform a visual inspection periodically to determine general condition. If corrosion is found on any part, remove the rust spots, clean, paint, and treat with the prescribed preservatives.

Note.—Touch-up painting will be in accordance with TM 9-2851.

d. REMOVAL FROM LIMITED STORAGE.

- (1) If the launchers are not shipped or issued upon expiration of the limited storage period, they may either be processed for another limited storage period or be further treated for stand-by storage (launchers inactivated for periods in excess of 90 days up to 3 years) by ordnance maintenance personnel.
- (2) If launchers to be shipped will reach their destination within the scope of the limited storage period, they need not be reprocessed upon removal from storage unless inspection reveals it to be necessary according to anticipated in-transit weather conditions.

Note.—All launchers that are to be reissued to troops within the continental limits of the United States will be inspected prior to shipment to determine their serviceability is in accordance with TB ORD 385.

- (3) Deprocess launchers when it has been ascertained that they are to be placed into immediate service. Remove all rust-preventive compounds and thoroughly lubricate as prescribed in section III, chapter 3.
- (4) Repair and/or replace all items tagged in accordance with (3) above.

c. **STORAGE SITE.** The preferred type of storage for launchers is under cover in open sheds or warehouses whenever possible. Where it is found necessary to store launchers outdoors, they must be protected against the elements as prescribed in SB 9-47.

76. Preservation, Packaging, and Packing

a. PRESERVATION.

- (1) *Cleaning.* Thoroughly clean launchers prior to the application of preservatives as prescribed in SB 9-65.
- (2) *Painting.* Repaint normally painted surfaces where paint has been removed or chipped, in accordance with TM 9-2851.
- (3) *Application of preservatives.*
 - (a) Coat bore of launchers by swabbing with heated rust-preventive compound (medium).

Caution: Do not dip launcher in compound. Exercise extreme care while applying compound to prevent it from contacting the firing mechanism.

- (b) Web slings will be preserved with water-, weather- and mildewing resistant re-treating compound (4-1131). Refer to TM 9-850 for cleaning method.

b. **PACKAGING.** Wrap the coupling ends of each launcher with greaseproof barrier-material, grade C.

c. **PACKING.** Launchers will be boxed and packed in accordance with the following instructions:

- (1) *Trial pack.* Before constructing a quantity of these boxes construct a trial pack and adjust the dimensions of the container or blocking, if necessary.
- (2) *Type of container.* The box is constructed as a style 2 nailed wood box. For additional basic information on nailed wood boxes refer to TM 9-2854.
- (3) *Cushioning material.* Apply suitable cushioning material, such as felt or flexible corrugated fiberboard, where contact is made between launchers and wood supports, to prevent movement and abrasion.
- (4) *Packing box.*
 - (a) *Boxing data.* Table III contains logistical boxing data for four 3.5-inch rocket launchers M20 or M20B1.
 - (b) *Bill of material.* The bill of material required to construct one complete style 2 nailed wood box (fig. 46) is listed in table IV. The indicating numbers are those referred to in tables IV and V, and (d) below.

Table III.—Logistical Data

	Dimension (in)		Volume and weight
	Inside	Outside	
Length.....	33 $\frac{3}{8}$	35 $\frac{7}{8}$	
Width.....	23 $\frac{1}{8}$	24 $\frac{1}{8}$	
Height.....	19	20	
Net weight (lb).....			(M20) 60 (M20B1) 56
Tare weight (lb).....			25
Gross weight (lb).....			(M20) 85 (M20B1) 81
Cubic displacement (cu ft).....			10.0
Ship tons (40 cu ft).....			0.25

Table IV.—Bill of Material

Indicating No.	Quantity required	Part name	Actual size (in)		
			Length	Width	Height
1	2	Ends ¹	23 $\frac{3}{8}$	19	$\frac{5}{8}$
2	4	Vertical end cleats.....	18 $\frac{7}{8}$	2 $\frac{1}{4}$	$\frac{5}{8}$
3	4	Horizontal end cleats.....	18 $\frac{1}{2}$	2 $\frac{1}{4}$	$\frac{5}{8}$
4	2	Sides ¹	35 $\frac{7}{8}$	19	$\frac{1}{2}$
5	2	Top and bottom.....	35 $\frac{7}{8}$	24 $\frac{1}{8}$	$\frac{1}{2}$
6	8	Side battens ²	18 $\frac{3}{4}$	1 $\frac{1}{2}$	$\frac{1}{2}$
7	4	Side battens ²	18 $\frac{3}{4}$	1 $\frac{1}{4}$	$\frac{1}{2}$
8	4	Side battens ²	18 $\frac{3}{4}$	1 $\frac{1}{2}$	$\frac{1}{2}$
9	2	Spacers.....	23	3 $\frac{3}{8}$	1 $\frac{3}{16}$
10	4	Blocks.....	5 $\frac{5}{8}$	3 $\frac{3}{8}$	1 $\frac{3}{16}$
11	2	Spacer blocks.....	5 $\frac{7}{8}$	3 $\frac{3}{8}$	1 $\frac{3}{16}$
12	4	Launcher supports (plywood).....	23	4	$\frac{5}{8}$
	2	Cushioning pads (corrugated fiber-board).	23	19	
	42 sq ft	Flexible waterproof barrier-material (for case liner—export shipment only).			
	2	Steel straps w/strap seals ³	96	$\frac{3}{8}$	0.020
	$\frac{1}{2}$ lb	Sixpenny cement-coated nails.....			
	24	No 6 gage wood screws.....			

¹ Ends, sides, top, and bottom may be made of several pieces, but no piece may be less than 2 $\frac{1}{2}$ inches wide.

² When assembling box these battens must be from $\frac{1}{8}$ to $\frac{1}{16}$ inch from the inside surface of the top and bottom.

³ Equivalent steel wire may be substituted.

(c) *Fastening schedule.* The fastening schedule shown in table V is for group II woods only. If woods of group I, III, or IV are used, or if the prescribed size of nail or screw is not available, adjust schedule as prescribed in TM 9-2854.

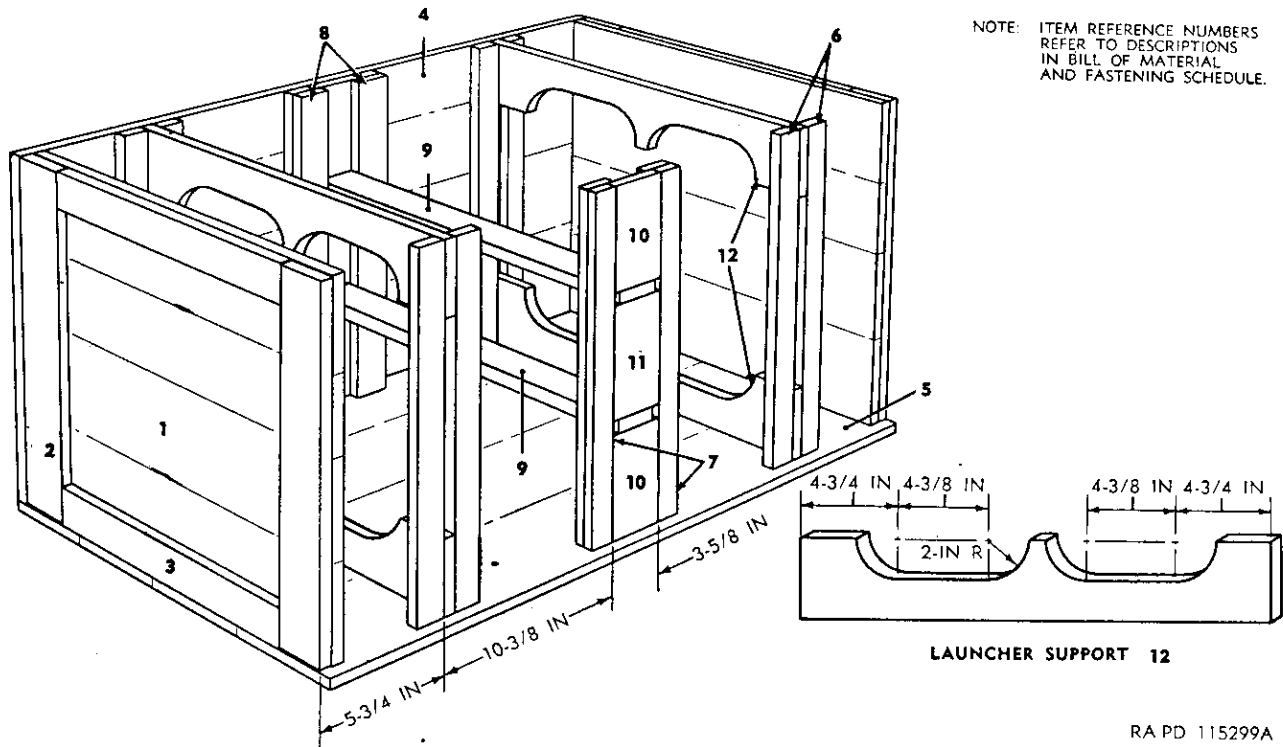

Figure 46. Packing box for four 3.5-inch Rocket Launchers M20 or M20B1.

Table V.—Fastening Schedule

Fasten part—	To part—	Nail size (cement- coated)	Maximum spacing (in.)	Notes
Cleats (2) and (3) -----	Ends (1) -----	6d	2	Stagger and clinch.
Side battens (6) ² -----	Sides (4) -----	6d	2	Do.
Side battens (7) -----	Sides (4) -----	6d	2	Do.
Side battens (8) -----	Side battens (7) -----	6d	2	Do.
Sides (4) -----	Ends (1) and cleats (2) -----	6d	2	Stagger.
Bottom (5) -----	Ends (1) and cleats (2) (3) -----	6d	2	Do.
Bottom (5) -----	Sides (4) -----	6d	2	
Top (5) -----	Ends (1) and cleats (2) (3) -----		3/4	Stagger seven No. 6 gage wood screws through each end.
Top (5) -----	Sides (4) -----		7	Five No. 6 gage wood screws through each side.

¹ If the nail specified is not available, use the next smaller size and reduce the spacing by 1/4 inch.

² For oversea shipment, place a flexible waterproof barrier case liner (table IV) inside the box before nailing side battens (6) and (7) to the sides. Coat the surface of the battens in contact with the case liner with a water-resistant adhesive.

(d) *Packing Procedure.*

1. Place two supports (12) in the spaces between side battens (6).
2. Slide two blocks (10) into the tee-slots formed by battens (7) and (8).
3. Latch the two parts of launchers together in carrying position. Slide spacer (9) through the shoulder rest of the two launchers.

Note.—Reverse the launchers end for end with the shoulder rests toward the center of the box.

Position spacer (9) between the side battens (8) so that the board rests flat upon blocks (10) with the packaged launchers on supports (12).

4. Position spacer blocks (11) in the tee-slots of side batten (7) and (8) so that they rest on spacer (9).
5. Repeat operation outlined in 3 above for the two top launchers.
6. Place the remaining two launcher supports (12) and blocks (10) in position.
7. Insert one corrugated cushioning pad at each end of box between launchers and ends (1) (not shown in fig. 46).
8. Secure the cover to the ends and sides with No. 6 gage wood screws. Apply two $\frac{3}{8}$ - x 0.020-inch steel straps around box approximately 6 inches from each end. Draw the straps tight so as to sink into the wood at the edges. Apply straps just prior to shipment, where practicable.

d. DOMESTIC MARKING. After the launchers have been processed and boxed, stencil or tag the outside of the container with the correct nomenclature, stock number, type of preservative applied, classification of launchers, date packed, and name of installation performing the inspection.

Note.—Do not mark any container unless the contents have been actually inspected and processed. For overseas shipment the containers will be marked in accordance with TM 3S-414.

Section II. DESTRUCTION OF MATÉRIEL TO PREVENT ENEMY USE

77. General

a. Destruction of the 3.5-inch rocket launcher, when subject to capture or abandonment in the combat zone, will be undertaken by the using arm only when, in the judgment of the unit commander,

such action is necessary in accordance with orders of, or policy established by, the Army commander.

b. The conditions under which destruction will be effected are command decisions in each case according to the tactical situation. Of several means of destruction, those most applicable to this launcher are—

Mechanical—Requires ax, pick, sledge, crowbar, or similar implement.

Burning —Requires gasoline, oil, or other inflammables.

In general, destruction of essential parts, followed by burning will usually be sufficient to render the matériel useless. However, selection of the particular method of destruction requires imagination and resourcefulness in the utilization of the facilities at hand under the existing conditions. Time is usually critical.

c. If destruction to prevent enemy use is resorted to, the matériel must be so badly damaged that it cannot be restored to a usable condition in the combat zone either by repair or cannibalization. Adequate destruction requires that all parts essential to the operation of the matériel, including essential spare parts, be destroyed or damaged beyond repair. However, when lack of time and personnel prevents destruction of all parts, priority is given to the destruction of those parts most difficult to replace, such as the sight and firing mechanism. Equally important, the same essential parts must be destroyed on all like matériel so that the enemy cannot construct one complete unit from several damaged ones. The following method of destruction for the launcher (par. 78) and its ammunition (par. 79) is offered as a guide.

78. Destruction of 3.5-Inch Rocket Launcher

Disassemble the launcher (par. 25a). Using a heavy implement such as a sledge hammer, dent and deform the barrels, bipod, monopod, and stock; smash the sight, the firing mechanism in the trigger grip, the barrel coupling lock, the barrel latch, and the contactor latch; and slash the gun sling. The damaged components should be scattered over a wide area or if ammunition or other materials are to be destroyed by fire (par. 79), the damaged components may be placed with the items to be burned. Elapsed time, about 5 minutes.

79. Destruction of Rockets

a. If destruction of rockets is directed, due consideration should be given to:

- (1) Accomplishment of the destruction in such a manner as to cause the greatest obstruction to enemy movement and also prevent hazard to friendly troops from fragments or uncontrolled flight of rockets.
- (2) Observance of appropriate safety precautions.

b. Rockets are most effectively destroyed by burning. To accomplish this, stack rockets, either packed or unpacked, in piles so that the rocket heads point toward the enemy, or in a trench or depression, head downward. Place inflammable materials such as paper, rags, brush, and wood around and on the pile. Pour gasoline and oil over the pile. Sufficient inflammable material must be used to insure a fire hot enough to destroy the rockets. Ignite and take cover.

c. Since ignition of the propellant in the rocket motor will cause some rockets to be projected in unpredictable flight, the danger area for the destruction of rockets should be considered as having a radius equivalent to the effective range. Generally, however, the rocket will travel in the same direction that it is pointed at the time of ignition.

APPENDIX

REFERENCES

1. Publication Indexes

The following publication indexes, and lists of current issue should be consulted frequently for latest changes or revisions of references given in this appendix and for new publications relating to matériel covered in this manual:

Index of administrative publications.....	SR 310-20-5
Index of Army motion pictures and film strips.....	SR 110-1-1
Index of Army training publications.....	SR 310-20-3
Index of blank forms and Army personnel classification tests.....	SR 310-20-6
Index of technical manuals, technical regulations, technical bulletins, supply bulletins, lubrication orders, modification work orders, tables of organization and equipment, reduction tables, tables of allowances, tables of organization, tables of equipment, and tables of basic allowances.....	SR 310-20-4
Introduction and index (supply catalogs).....	ORD 1
Military training aids.....	FM 21-8
Ordnance major items and combinations and pertinent publications.....	SB 29-1

2. Supply Catalogs

The following Department of the Army supply catalogs pertain to this matériel:

a. AMMUNITION.

Ammunition instruction material for aircraft bombs, grenades, pyrotechnics, and rockets.....	ORD 11 SNL S-6
Rockets, all types and components.....	ORD 11 SNL S-9

b. MAINTENANCE AND REPAIR.

Cleaners, preservatives, lubricants, recoil fluids, special oils, and related maintenance materials.....	ORD 3 SNL K-1
--	---------------

Tools, maintenance for repairs of small and hand
arms, and pyrotechnic projectors.----- ORD 6 SNL B-20

c. WEAPON.

Launcher, rocket, 3.5-inch, M20 and M20B1----- ORD (*) SNL B-42

3. Explanatory Publications

The following explanatory publications contain information pertinent to this matériel and associated equipment:

a. AMMUNITION.

Ammunition, general----- TM 9-1900

Qualifications in arms and ammunition training allowances ----- AR 775-10

Regulations for firing ammunition for training, target practice, and combat----- SR 385-310-1

Rockets ----- TM 9-1950

b. CAMOUFLAGE.

Camouflage, basic principles----- FM 5-20

Camouflage of individuals and infantry weapons----- FM 5-20A

c. DECONTAMINATION.

Decontamination----- TM 3-220

Defense against chemical attack----- FM 21-40

d. DESTRUCTION TO PREVENT ENEMY USE.

Ordnance service in the field----- FM 9-5

e. GENERAL.

Accounting for lost, damaged, or destroyed property--- SR 735-150-1

Cleaning, preserving, sealing, and related materials issued for ordnance matériel----- TM 9-850

General—Unsatisfactory equipment report (Reports control symbol CSGLD-247)----- SR 700-45-5

Reports of accident experience----- SR 385-10-40

Targets, target material, and training course lay-outs----- TM 9-855

f. SHIPMENT AND LONG-TERM STORAGE.

Army marking directive----- TM 38-414

Army shipping document----- TM 38-705

Instruction guide: Ordnance packing and shipping (posts, camps, and stations)----- TM 9-2854

*See ORD 1, Introduction and Index, for published pamphlets of the ordnance section of the Department of the Army supply catalog.

RESTRICTED

Ordnance storage and shipping chart—Group B.....	SB 9-OSSC-B
Painting instructions for field use.....	TM 9-2851
Protection of ordnance matériel in open storage.....	SB 9-47
Shipment of supplies and equipment.....	SR 745-45-5
Standards for oversea shipment and domestic issue of ordnance matériel other than ammunition and Army aircraft	TB ORD 385



RESTRICTED