

DEPARTMENT OF THE ARMY TECHNICAL MANUAL

**OPERATOR'S AND ORGANIZATIONAL
MAINTENANCE MANUAL
INCLUDING REPAIR PARTS AND
SPECIAL TOOLS LIST**

**RIFLE, CALIBER .30, AUTOMATIC,
BROWNING, M1918A2, W/E
(1005-674-1309)**

**This copy is a reprint which includes
current pages from Change 1.**

HEADQUARTERS, DEPARTMENT OF THE ARMY

AUGUST 1969

WARNING

DANGEROUS PROCEDURES

If not ready to fire, be sure the change lever is placed in S (safe) position

DANGEROUS CONDITIONS

Cartridges which have been subjected to temperature of 135°F. (uncomfortable to hold) or more, due to direct radiation from the sun or other sources of heat, shall not be fired as dangerous high chamber pressures may result. When such cartridges are returned to lower temperatures, they are safe to fire.

In the event of a misfire the round will remain locked in the chamber for the prescribed time intervals, the gun trained on the target and personnel cleared from the area.

A cook-off will occur after ten seconds of contact with the chamber of a hot barrel.

Do not attempt to fire weapon if water is present in barrel. Fording, heavy rain, or fog can cause water to be present in the barrel.

DANGEROUS SOLUTIONS

Avoid skin contact with PC 111. The compound should be washed off thoroughly with running water if it comes in contact with the skin. A good lanolin base cream, after exposure to compound, is helpful. The use of gloves and protective equipment is recommended.

CHANGE }
No. 1 }

HEADQUARTERS
DEPARTMENT OF THE ARMY
WASHINGTON, D.C., 28 November 1972

**Operator's and Organizational Maintenance Manual
Including Repair Parts and Special Tools Lists**

**RIFLE, CALIBER .30, AUTOMATIC, BROWNING, M1918A2, W/E
(1005-674-1309)**

TM 9-1005-208-12, 1 August 1969, is changed as follows:

Table 3-2.1. Expendable and Consumable Supplies - Continued

Page 1, paragraph 1-2b. Change last sentence to read: Reports should be submitted on DA Form 2028, Recommended Changes to Publications, and forwarded direct to Commander, US Army Weapons Command, ATTN: AMSWE-MAS-SP, Rock Island, IL 61201.

Paragraph 1-4a. Add to end of paragraph the following statement: "One each cartridge magazine (1, fig C-1), front sight cover (6, fig C-4), carrying handle (5, fig C-5), and small arms sling (1, fig C-5) are furnished as component items with each weapon."

Page 11. Add the following after table 3-2.

Table 3-2.1. Expendable and Consumable Supplies

<i>FSN</i>	<i>Description</i>	<i>Symbol</i>
8020-244-0153	BRUSH ARTISTS: metal, ferrule, flat, chisel edges, 7/16 w, 1-118 lg exposed bristle H-B-241 (81348)	
7920-205-2401	BRUSH, CLEANING, TOOL AND PARTS: rnd, 100 percent tampico fiber, 1-1/16 at ferrule brush din, 2-7/8 clear of block brush lg MS16746-29 (96906)	
6850-965-2332	CARBON REMOVING COMPOUND: (5 gal pail) P-C-111 (81348) CLEANING COMPOUND, RIFLE BORE: MIL-C-372 (81349)	RBC

<i>FSN</i>	<i>Description</i>	<i>Symbol</i>
6850-224-8656	2 oz bottle	
6850-224-6657	8 oz can	
6850-224-6663	1 gal can	
5350-221-0872	CLOTH, ABRASIVE, CROCUS: ferric oxide and quartz, jean-clothbacking, closed-coating, 9 w, 11 lg, 50-sh-sleeve, R-C-458 (81348)	CA
6850-281-1985	DRY CLEANING SOLVENT: (1 gal can) P-D-680 (81348)	SD
8010-221-0611	LINSEED OIL, RAW: (1 gal can) LUBRICATING OIL, GENERAL PURPOSE: VV-L-800 (81348)	PL-S
9150-273-2389	4 oz can	
9150-231-6689	1 qt can	
9150-292-9689	LUBRICATING OIL, WEAPONS: for below zero operations (1 qt can) MIL-L-14107 (81349)	LAW
7920-205-1711	RAG, WIPING: cotton, (50 lb bale) DDD-R-30 class 2, grade B (81348)	
1005-288-3565	SWAB, SMALL ARMS CLEANING: cotton 2-1/2 sq (1,000 in pkg) 5019316 (19204)	

Page 35 appendix C. Title is superseded as follows:

**BASIC ISSUE ITEMS LIST
AND
ITEMS TROOP INSTALLED OR AUTHORIZED LIST
AND
ORGANIZATIONAL MAINTENANCE REPAIR PARTS
AND
SPECIAL TOOLS LIST**

Paragraph C-1 is changed as follows:

C-1. Scope

This appendix lists basic issue items, items troop installed or authorized, repair parts and special tools required by the crew/operator for operation and required for the performance of organizational maintenance of the rifle M1918A2.

Paragraph C-2 is changed as follows:

C-2. General

This basic issue items, items troop installed or authorized, repair parts and special tools list is divided into the following sections:

a. Basic Issue Items List - Section II. A list, in alphabetical sequence, of items absolutely essential for operation of the end item, which are furnished with and must be turned in with the end item.

b. Items Troop Installed or Authorized List - Section III. A list, in alphabetical sequence, of items required by the operator for sustained operation of the end item. These discretionary items will be requisitioned by the unit in accordance with its mission requirements. They may accompany the end item, but are not subject to be turned in with it.

Delete paragraph C-2c. Change C-2d to C-2c; C-2e to C-2d; and C-2f to C-2e.

Page 36. Paragraphs C-3d through g are superseded as follows:

d. Unit of Measure (U/M). Indicates the standard or basic quantity by which the listed item is used in performing the actual maintenance function. This measure is expressed by a two-character alphabetical abbreviation, e.g., ea, in, pr, etc, and is the basis used to indicate quantities. When the unit of measure differs from the unit of issue, the lowest unit of issue that will satisfy the required units of measure will be requisitioned.

e. Quantity Furnished with Equipment (Basic Issue Items Only). Indicates the quantity of the item furnished with the equipment.

f. Quantity Authorized (Items Troop Installed or Authorized Only). Indicates the quantity of the item authorized to be used with the equipment.

g. Quantity Incorporated in Unit. Indicates the quantity of the item used in that functional group/assembly. A "V" appearing in this column in lieu of a quantity indicates that no specific quantity is applicable, e.g., shims, spacers, etc.

Delete paragraphs C-3h, C-3i and C-3j. Change C-3k to C-3h.

Page 37. Change C-3l to C-3i.

Page 38. Section II is superseded as follows:

Section II. BASIC ISSUE ITEMS LIST

(1) Federal stock No.	(2) Description <i>Reference number & mfr. code</i> <i>Usable on code</i>	(3) Unit of meas	(4) Qty furn with equip	(5) Illustration	
				(a) Fig. No.	(b) Item No.
1005-716-2547	CAP: MAGAZINE 7162547 (19204)	EA	1	C-4	5

Page 40. Section III is superseded as follows:

Section III. ITEMS TROOP INSTALLED OR AUTHORIZED LIST

(1) Federal stock No.	(2) Description <i>Reference Number & mfg. code</i> <i>Usable on code</i>	(3) Unit of meas	(4) Qty auth
1005-610-8828	BRUSH, CLEANING, SMALL ARMS: M6 CHAMBER 6108828 (19204)	EA	1
1005-556-4174	BRUSH, CLEANING, SMALL ARMS: BORE 5564174 (19204)	EA	1
1005-652-8362	BRUSH SET, CLEANING, SMALL ARMS: CHAMBER 6528362 (19204)	EA	1
1005-716-2547	CAP: MAGAZINE 7162547 (19204)	EA	18
1005-550-6573	CASE, SMALL ARMS CLEANING ROD: 5506573 (19204)	EA	1
1005-722-8907	ENVELOPE: FABRIC, 2-BUTTON, 3X 4-7/8 7228907 (19204)	EA	1
4933-652-9950	EXTRACTOR, RUPTURED CARTRIDGE CASE: 7790352 (19204)	EA	1
1005-550-7913	FILLER: MAGAZINE 5507913 (19204)	EA	1
1005-793-6761	HANDLE ASSEMBLY: CLEANING ROD 7266115 (19204)	EA	1
1005-556-4076	MAGAZINE, CARTRIDGE: 5564076 (19204)	EA	18
4933-508-0340	REAMER ASSEMBLY, GAS CYLINDER CLEANER: 7268211 (19204)	EA	1
1005-726-6109	ROD SECTION, CLEANING, SMALL ARMS: 7266109 (19204)	EA	1
1005-726-6110	SWAB HOLDER SECTION, SMALL ARMS CLEANING ROD: 7266110 (19204)	EA	1
4933-726-6450	WRENCH, COMBINATION: HOOK, SPANNER AND SCREW- DRIVER 7266450 (19204)	EA	1

Page 41. Section IV. Deleted.

By Order of the Secretary of the Army:

Official:

CREIGHTON W. ABRAMS
General, United States Army
Chief of Staff

VERNE L. BOWERS
Major General, United States Army
The Adjutant General

Distribution:

To be distributed in accordance with DA Form 12-40 (qty rqr block No. 132). Organizational Maintenance requirements for Rifle, Caliber .30, Automatic, Browning M1918A2.

TECHNICAL MANUAL }
 No. 9-1005-208-12 }

HEADQUARTERS,
 DEPARTMENT OF THE ARMY
 WASHINGTON, D. C., 1 August 1969

**OPERATOR'S AND ORGANIZATIONAL MAINTENANCE MANUAL
 INCLUDING REPAIR PARTS AND SPECIAL TOOLS LISTS**

**RIFLE, CALIBER .30, AUTOMATIC: BROWNING, M1918A2,
 W/E (1005-674-1309)**

This manual is current as of 30 June 1969

	Paragraphs	Page
CHAPTER 1. INTRODUCTION		
Section I. General	1-1 - 1-3	1
Section II. Description and data	1-4 - 1-5	1
CHAPTER 2. OPERATING INSTRUCTIONS		
Section I. Controls	2-1 - 2-2	3
Section II. Operation under usual conditions	2-3 - 2-10	3
Section III. Operation under unusual conditions	2-11 - 2-16	6
CHAPTER 3. OPERATOR AND ORGANIZATIONAL MAINTENANCE INSTRUCTIONS		
Section I. Service upon receipt of materiel.....	3-1 - 3-2	9
Section II. Repair parts, special tools and equipment	3-3 - 3-4	9
Section III. Operators lubrication instructions	3-5 - 3-6	9
Section IV. Preventive maintenance services	3-7	10
Section V. Troubleshooting.....	3-8	11
Section VI. Operator maintenance.....	3-9 - 3-12	12 - 15
Section VII. Organizational maintenance procedures.....	3-13	20
CHAPTER 4. MAINTENANCE OF MATERIEL USE IN CONJUNCTION WITH MAJOR ITEM.....	4-1	25
CHAPTER 5. AMMUNITION	5-1 - 5-6	27, 28
CHAPTER 6. DESTRUCTION TO PREVENT ENEMY USE.....	6-1	29
APPENDIX A. REFERENCES	A-1 - A-3	31
Section B. MAINTENANCE ALLOCATION CHART		
Section I. Introduction	B-1 - B-3	33
Section II. Maintenance allocation chart for Rifle Caliber .30, Automatic, Browning, M1918A2.....		33
APPENDIX C. ORGANIZATIONAL MAINTENANCE REPAIR PARTS AND SPECIAL TOOLS LISTS		
Section I. Introduction	C-1 - C-6	35 - 37
Section II. Basic issue items list (Figs C-1 - C-5).....		38
Section III. Maintenance and operating supplies		40
Section IV. Prescribed load allowance.....		41
Section V. Organizational Repair Parts List.....		42
Section VI. Repair parts for:		
Components and assemblies (Fig C-1).....		46
Trigger guard assembly (Fig C-2).....		47
Bolt group (Fig C-3).....		48
Material required for cold weather climates (Fig. C-6)		51
Section VII. Special tools, test and support equipment (Figs C-4 - C-5)		44
Section VIII. Federal stock number and reference number cross-reference to figure and item number.....		52

*This manual supersedes TM 9-1005-208-12P, 28 January 1964, in its entirety.

CHAPTER 1

INTRODUCTION

Section I. GENERAL

1-1. Scope

This manual contains instructions for the operation and organizational maintenance of Caliber .30 Browning Automatic Rifle M1918A2 allocated by the MAC (app B).

1-2. Forms and Records

a. General. Refer to TM 38-750 (Army Equipment Records Procedure) for forms and records required.

b. Recommendations for Maintenance Manual Improvements. Report of errors, omissions and

recommendations for improving this manual by the individual user is encouraged. Reports should be submitted on DA Form 2028, Recommended Changes to Publications, and forwarded direct to Commander, US Army Weapons Command, ATTN: AMSWE-MAS-SP, Rock Island, IL 61201.

1-3. Administrative Storage

Refer to TM 740-90-1 for administrative storage.

Section II. DESCRIPTION AND DATA

1-4. Description

a. General. The Caliber .80 Browning Automatic Rifle M1918A2 (fig. 1-1) is a fully automatic, air-cooled, gas-operated, magazine fed, shoulder-type weapon, designed primarily for use with a bipod. The rifle can be easily disassembled into groups and assemblies. It is composed of the magazine, trigger guard assembly, bolt group, gas cylinder and fore end group, slide and piston group, butt stock, buffer, and actuator group, bipod assembly, rear sight assembly, and barrel and receiver group. The rifle contains a cyclic rate mechanism which is housed in the stock and trigger guard mechanism. This mechanism allows two rates of automatic fire, one at 550 rounds per minute (normal cyclic rate) and one at 350 rounds per minute (slow cyclic rate). A brief description of the components is as follows: One each cartridge magazine (1, fig C-1), front sight cover (6, fig C-4), carrying handle (5, fig C-5), and small arms sling (1, fig C-5) are furnished as component items with each weapon.

b. Magazine. The magazine is located just forward of the trigger guard assembly at the bottom of the receiver. It holds 20 rounds of ammunition.

c. Trigger Guard Assembly. The trigger guard assembly is located on the bottom of the receiver.

d. Bolt Group. The bolt group is housed within the receiver.

e. Gas Cylinder and Fore End Group. The gas cylinder and fore end group is located just below the barrel on the front of the receiver. It consists of the fore end shield, gas cylinder assembly, fore end, front swivel assembly, and gas cylinder gun.

f. Slide and Piston Group. The slide and piston group is housed within the gas cylinder and fore end group and receiver.

g. Butt Stock, Buffer, and Actuator Group. The butt stock, buffer, and actuator group is housed within the stock of the rifle.

h. Bipod Assembly. The bipod assembly is located at the muzzle end of the barrel and is secured to the barrel by the friction washer, a flash hider and biped bearing.

i. Rear Sight Assembly. The rear sight assembly is located on the top of the receiver just forward of the stock.

j. Barrel and Receiver Group. The barrel and receiver group serves as a support for all major groups and assemblies of the rifle.

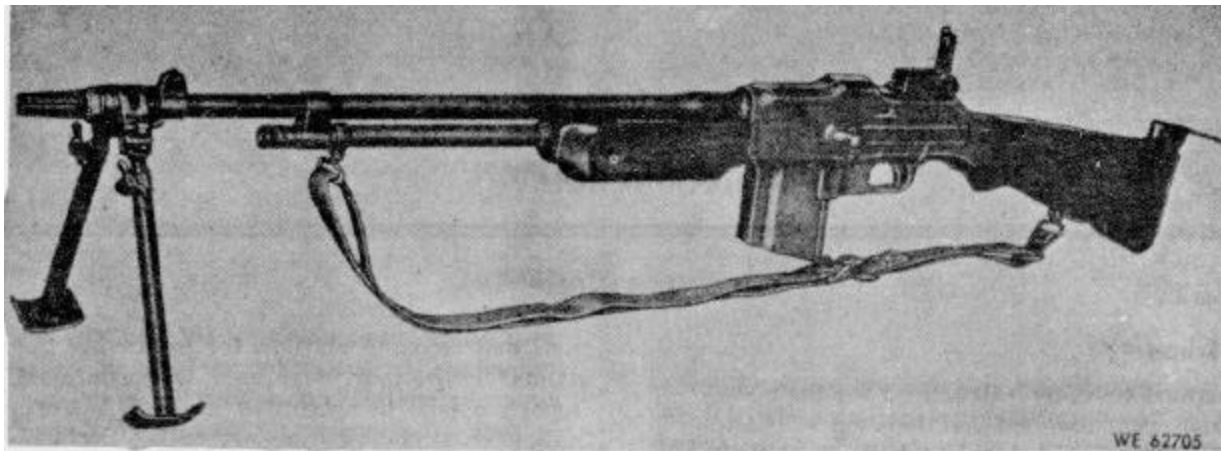

Figure 1-1. Caliber .30 Browning Automatic Rifle M1918A2 - left front view.

1-5. Tabulated Data

Weight	19.4 lb	Capacity.....	20 rds
Weight of magazine	0.44 lb	Cyclic rate:	
Length of rifle.....	47.8 in	High rate	550 to 650 rds per min
Length of barrel.....	24.07 in	Low rate.....	350 to 450 rds per min
Rifling:		Cooling.....	air
Number of grooves	4	Sight radius	31.125 in
Right hand twist (one		Trigger pull:	
turn in).....	10 in	Maximum	10 lb
Method of actuation.....	gas operated	Minimum	6 lb
Feeding.....	magazine	Ammunition	Ball, armor piercing, tracer, dummy, and blank

CHAPTER 2

OPERATING INSTRUCTIONS

Section I. CONTROLS

2-1. General

This section describes, locates, illustrates, and furnishes the operator essential information pertaining to the various controls provided for the proper operation of the materiel.

2-2. Controls

Refer to figure 2-1 for controls and their functions.

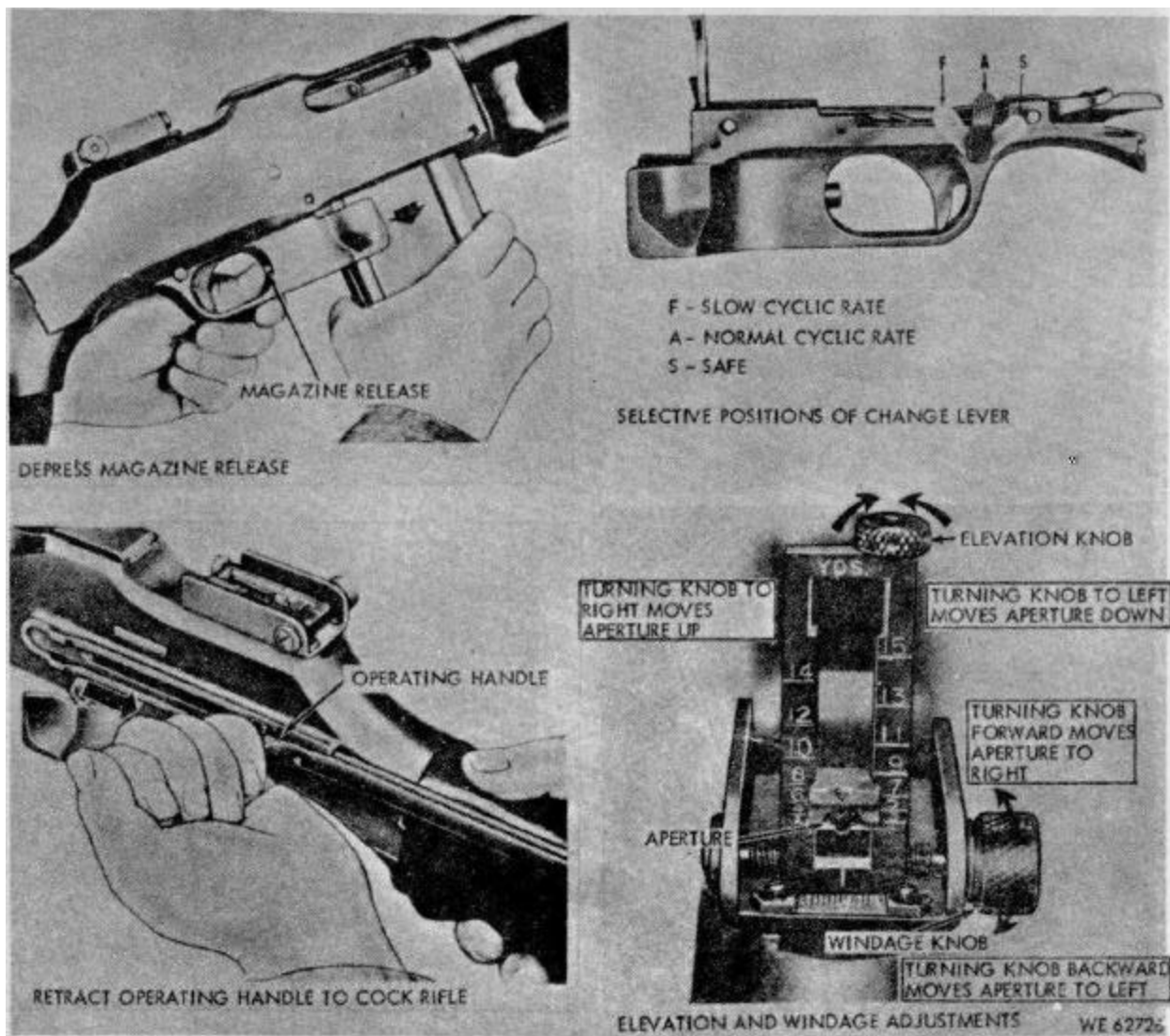

Figure 2-1. Controls.

Section II. OPERATION UNDER USUAL CONDITIONS

2-3. General

This section contains instructions for the operation of the rifle under moderate temperatures and humidity. Instructions for operation under unusual conditions are covered in section III.

2-4. Preparation for Firing

- a. Refer to table 3-4 for cleaning and lubrication instructions.
- b. Clear rifle as shown in figure 2-2.

2-5. Loading

- a. Loading the Magazine. The magazine has a maximum capacity of 20 rounds and may be loaded with any amount up to that capacity. The nose of the bullet must point to the short portion of the magazine. Use of the magazine filler is most helpful for rapid loading of the magazine. Place the filler over the open end of the magazine and funnel the cartridges into its mouth.
- b. Loading the Rifle. Before loading the rifle, set the change lever to S (safe position, fig. 2-1). The weapon is cocked before a magazine

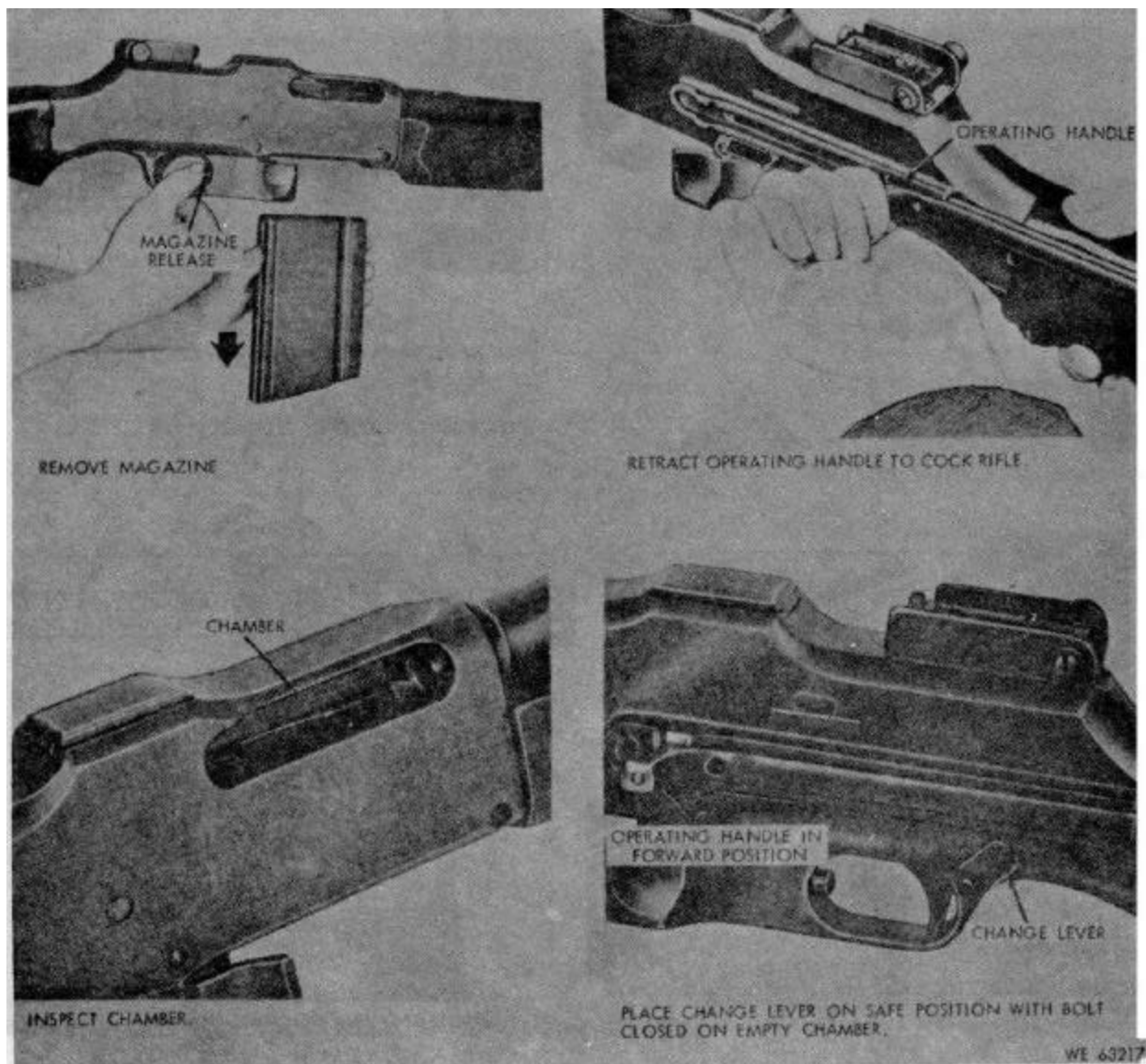

Figure 2-2. Clearing rifle.

is loaded. The weapon may be loaded with either hand holding the magazine with its base in the palm. The tips of the cartridges must point toward the muzzle of the weapon. Using the magazine guides, insert the magazine into the magazine feedway. Tap up on the magazine base so that the magazine will be fully seated (the magazine notch engaged by the magazine catch). The rifle is now loaded and can be fired when the change level is placed in the A (normal cyclic rate) or F (slow cyclic rate) position.

Warning. If not ready to fire, be sure the change lever is placed in S (safe) position.

2-6. Precautions in Firing Ammunition

a. The general precautions concerning the care, handling, preservation and destruction of ammunition as described in TM 9-1300-206 will be observed. In addition, the precautions below will be closely observed.

b. Ammunition which is badly corroded will not be fired.

c. Cartridge bases are easily dented and should be protected from hard knocks and blows. Dented cartridge cases may jam in the chamber and cause difficulty in extraction.

d. Cartridges which have been seriously damaged or those having loose bullets will not be used.

e. The cartridges will be kept clean and free of foreign matter.

Warning. Cartridges which have been subjected to temperature of 135°F. (uncomfortable to hold) or more, due to direct radiation from the sun or other sources of heat, shall not be fired as dangerous high chamber pressures may result. When such cartridges are returned to lower temperatures, they are safe to fire.

2-7. Firing

a. *M1918A2 Rifle (Fully Automatic Weapon)*. No provision has been made for semi-automatic fire other than by the quick release of the trigger.

b. *Change Lever*. The automatic rifle has capabilities for two distinct cyclic rates of fire (fig. 2-1). This determination is made by the appropriate positioning of the change lever. There are three possible positions for this change lever. Note that repositioning of the change lever does not necessitate the cocking of the weapon.

c. *F Setting*. With the change lever in this position (fig. 2-1), the weapon's firing capability is at the slow cyclic rate (about 350 rounds per minute). When the trigger is depressed or held back on a loaded weapon, the rifle will continue to fire at this rate until the trigger is released or the magazine is emptied.

d. *A Setting*. Normal cyclic rate is experienced when the change lever is positioned at setting A (about 550 rounds per minute) (fig. 2-1).

e. *S Setting*. When the change lever is positioned at S (fig. 2-1), the automatic rifle cannot fire and is safe. Because the trigger is blocked by the change lever from initiating the firing function, it remains immobile when pressure is applied.

f. *Zeroing*. Refer to FM 23-15.

2-8. Stoppage and Immediate Action

a. A stoppage is any unintentional interruption in the cycle of operation; it occurs when the rifle stops firing, or fails to fire, through no fault of the rifleman. A stoppage may be a failure to feed, chamber, fire, extract, or eject. The most common cause is a defective magazine.

b. A malfunction is a failure of the weapon to function satisfactorily. A malfunction may or may not become evident by actual stoppage of fire, i.e., a runaway rifle or one which a reduction in the normal rhythm or cadence of automatic fire. Malfunctions may also be caused by mud, sand, ice, etc., entering the mechanism.

c. Immediate action is the prompt action taken by the firer to correct the stoppage. The first phase of immediate action is as follows:

(1) Pull the operating handle all the way to the rear. This should remove any cartridge or cartridge case remaining in the chamber, providing the extractor, extractor spring or the ejector are not broken. The weapon is now cocked.

(2) Push the operating handle all the way forward.

(3) Tap up firmly on the bottom of the magazine. If the magazine is not fully seated, this should seat the magazine, providing the magazine catch, spring, and magazine are serviceable.

(4) Attempt to fire the rifle. If the stoppage is not corrected, immediately perform the second phase of action as follows:

(a) Pull the operating handle to the rear.

(b) Look into the ejection port to see that the chamber is clear.

(c) Inspect to determine cause of malfunction and take appropriate action. (See table 3-3, troubleshooting.)

2-9. Misfires and Cook-Offs

a. General. Although the following described malfunctions are rarely encountered, all personnel concerned should be sufficiently familiar to recognize them and act accordingly. Knowing the nature of each kind of malfunction, as well as the proper preventive and corrective procedures, will be instrumental in forestalling injury to personnel and damage to materiel. General precautions for removing chambered cartridges associated with these malfunctions are described in b, below.

Warning. In the event of a misfire the round will remain locked in the chamber for the prescribed time intervals, the rifle trained on the target and personnel cleared from the area.

(1) *Misfire.* A misfire is a complete failure to fire. It may be due to a faulty firing mechanism or a faulty element in the propelling charge explosive train.

(2) *Cook Off.* A cook-off is a functioning of any or all of the explosive components of a cartridge chambered in a very hot weapon due to the heat. To prevent injury from a cook-off, observe the time limit prescribed in b below.

b. Precautions. After a failure to fire, the following general precautions, as applicable, will be observed:

Warning. A cook-off will occur after, ten seconds of contact with the chamber in a hot barrel.

(1) Attempt to remove the cartridge before ten seconds has elapsed.

(2) If a cartridge is chambered in a very hot barrel and cannot be fired or removed, there is a possibility of a cook-off. If this occurs, and situation permits, all personnel except the operator must remain clear of the rifle for a minimum of 15 minutes.

(3) The operator will keep the rifle trained in a safe direction.

2-10. Unloading

Refer to figure 2-2.

Section III. OPERATION UNDER UNUSUAL CONDITIONS

2-11. General Conditions

a. Refer to table 3-4 for cleaning and lubricating instructions under unusual conditions and table 3-2 for preventive maintenance checks and services to be made when the materiel is subjected to unusual conditions.

b. Report any chronic failure of materiel resulting from subjection to extreme conditions in accordance with TM 38-750.

2-12. Operation in Extreme Cold

a. In climates where the temperature is consistently below 0°F., it is necessary to prepare the materiel for cold-weather operation. The rifle should be cleaned and lubricated as indicated in table 3-4 and paragraph 3-6.

b. Operate the various controls through their entire range, at intervals, as required. This aids in keeping them from freezing in place and reduces the effort required to operate them.

c. Materiel not in use and stored outside must be protected with a proper cover.

d. See FM 31-70 for further information on operations in the Arctic.

2-13. Operation in Extreme Heat

a. Hot Climates.

(1) When operating in hot climates, the coating of oil necessary for operation and preservation will dissipate quickly. Inspect the rifle frequently, paying particular attention to all hidden surfaces of the trigger guard assembly and bolt group.

(2) Perspiration contributes to corrosion because it contains acids and salts. After handling rifle, clean, wipe dry and oil using general-purpose lubricating oil (PL special).

b. Hot, Dry Climates. Clean and oil the bore of the rifle more frequently when operating in hot, dry climates.

2-14. Operations in Dusty and Sandy Areas

a. Clean and keep thoroughly dry. Do not lubricate. Even a light coat of oil will attract foreign matter, especially sand and dust, a potential cause of mechanical breakdown. During disassembly and-assembly operations, shield parts whenever possible.

b. When moving out of sandy terrain, clean and lubricate as indicated in table 3-4 and paragraph 3-6.

2-15. Operations Under Rainy, Humid Conditions and Salt Water Areas

a. Inspect the materiel more frequently when operating in hot, moist areas.

b. For lubricating instructions, refer to paragraph 3-6.

2-16. Operation After Fording

Warning. Do not attempt to fire weapon if water is present in barrel. Fording, heavy rain, or fog can cause water to be present in the barrel.

Observe the following procedures to empty water from the barrel:

a. Point the muzzle down.

b. If bolt is in forward position (closed), pull operating handle rearward. An open bolt will assist drainage of water.

c. Maintain bolt in open position (cocked) and operating handle forward. After water has been drained from barrel, weapon can be fired.

Note. Clean and lubricate in accordance with table 3-4 and paragraph 3-6 as soon as possible.

CHAPTER 3

OPERATOR AND ORGANIZATIONAL MAINTENANCE INSTRUCTIONS

Section I. SERVICE UPON RECEIPT OF MATERIEL

3-1. General

a. When a rifle is received, it is the responsibility of the officer in charge to determine whether the materiel has been properly prepared for service by the supplying organization and to be sure it is in condition to perform its function.

b. A record will be made of all missing parts, tools and equipment, and any malfunctions. Corrective action will be initiated as quickly as possible.

3-2. Services

Refer to table 3-1 for services performed upon receipt of materiel.

Table 3-1. Service Upon Receipt of Materiel

Step	Action	Reference
1	Check to determine that all Basic Issue Items have been furnished.	App C, sect II
2	Clear rifle.	Fig 2-2
3	Remove trigger guard assembly from rifle and visually inspect for proper assembly, damage, and missing parts.	Fig 3-2 and C-2
4	Clean and lubricate rifle.	Tables 3-4 and 3-5 and para 3-6
5	Reassemble the weapon.	Fig 3-2
6	Hand function to insure proper operation.	Para 3-12
7	Check magazine for positive retention and functioning of magazine catch.	

Section II. REPAIR PARTS, SPECIAL TOOLS AND EQUIPMENT

3-3. Tools and Equipment

Tools and equipment issued with or authorized for the operator and organizational maintenance are listed in appendix C.

3-4. Repair Parts

Repair parts for the operator and organizational maintenance are listed in appendix C.

Section III. OPERATOR'S LUBRICATION INSTRUCTIONS

3-5. General

The operator will be responsible for the lubrication of the automatic rifle. No additional lubricating instructions are provided for organizational maintenance.

a. *General.* Make certain all metal parts are cleaned and dried thoroughly before applying the lubricant. Wooden components should also be free of foreign matter and dried before applying linseed oil. For lubricants refer to appendix C. Cleaning instructions are contained in tables 3-4 and 3-5.

3-6. Instructions

Lubricating instructions furnished for usual conditions and unusual conditions are listed in a through c below.

b. Usual Conditions.

(1) All metal parts will be lubricated with a light coat of general purpose lubricating oil (PL special). This protective film must be maintained on all metal components at all times. Proper lubrication can be obtained by wiping the parts with a well oiled rag. Never lubricate any part, operating or otherwise, with an excessive coat of oil.

(2) Wooden components will be treated periodically (at least once a month) with raw linseed oil. Rub the oil into the wood with the palm of the hand until the component is dry.

c. Unusual Conditions.

(1) In hot climates whether humid, dry, or sandy, daily care must be exercised. In humid or rainy conditions, keep weapon lightly oiled when not in use. Periodic disassembling may be necessary for drying purposes and light lubrication. PL special will be used. In hot, dry climates where dust and sand prevail, the weapon will be wiped dry of all lubricants. When leaving sandy terrain, wipe rifle clean at once and lubricate with PL special.

(2) In hot climates, whether wet or dry, wooden components tend to either swell or shrink. A light coat of raw linseed oil rubbed in with the heel of the hand will aid in keeping the wood in good condition.

Note. Care should be taken that linseed oil does not get into the mechanism or on metal parts. Linseed oil becomes gummy when dry.

(3) When using the weapon at zero temperature or below, weapons lubricating oil (LAW) will be employed. Before using the rifle in such temperatures, after cleaning thoroughly, dry the working parts. Lubricate the working surfaces of parts by rubbing with a cloth slightly dampened with LAW.

(4) Whenever a cold weapon is placed indoors, allow it to warm to room temperature. After cleaning, and thoroughly drying the condensation that has formed, lubricate all metal surfaces with LAW.

Section IV. PREVENTIVE MAINTENANCE SERVICES

3-7. General

a. Preventive maintenance is the systematic care, inspection, and servicing of equipment to keep it in serviceable condition, prevent breakdowns, and assure maximum operational readiness. The operator's role in the performance of preventive maintenance service is:

(1) To perform daily service on the rifle.

(2) To help the organizational unit armorer perform any scheduled periodic services which are authorized to them.

b. In addition to procedures outlined in table 3-2, perform the following: remove rust, dirt, grit, gummed

oil, and water as these will cause rapid deterioration of the inner mechanism and outer surfaces. Take particular care to keep all surfaces clean and lubricated. Do not clean or polish outer surfaces of the weapon with a treated cloth or other commercial compounds.

c. Tighten loose parts and replace broken or worn parts, as authorized.

d. Every six months check to see if all modifications have been applied. Refer to DA Pam 310-7. No alteration or modification will be made except as authorized by the modification work order.

Table 3-2. Preventive Maintenance Checks and Services

Item No.	Interval						B - Before Operation D - During operation	A - After operation W - Weekly	M - Monthly Q - Quarterly	Item to be inspected	Procedure	Reference
	Operator Organizational											
	Daily											
1	X		--	--	--	--			**Rifle	Visually inspect the chamber and bore for condition and obstruction. Attach a dry swab to the cleaning rod and pass it through the bore. Make sure that the swab passes completely through the bore and into the chamber.		
*2	X	--	--	--	--	--			Rifle	Check for missing or broken parts. Also make certain retaining pins secure.		
*3	X	--	--	--	--	--			Rifle	Hand function to assure proper operation.	Para 3-12	
*4	X	--	--	--	--	--			Rifle	Check magazine for positive retention and functioning of magazine catch.		
*5	--	--	x	--	--	--			Rifle	Clean and lubricate	Tables 3-4, 3-5, and para 3-6	

Table 3-2. Preventive Maintenance Checks and Services--Continued

Item No.	Interval						Item to be inspected	Procedure	Reference
	Operator		Organizational						
	Daily								
	B	D	A	W	M	Q			
6	X	--	--	--	--	--	Rifle	Check bipod for looseness in flash hider (bearing). Check locking function of thumb screws, folding and locking action of legs, and locking of sliding legs. During periods of inactivity, perform the above services every 90 days, unless inspection reveals more frequent servicing is necessary.	Table 3-4
7	--	--	--	--	--	X	Rifle		

*Will be performed weekly, unless daily schedule is performed as a result of firing.

**Will be performed more frequently under unusual conditions.

Table 3-2.1 Expendable and Consumable Supplies

FSN	Description	Symbol	FSN	Description	Symbol
8020-244-0153	BRUSH ARTISTS: metal, ferrule, flat, chisel edges, 7/16 w, 1-118 lg exposed bristle H-B-241 (81348)	RBC	6850-281-1985	DRY CLEANING SOLVENT: (1 gal can) P-D-680 (81348)	SD
7920-205-2401	BRUSH, CLEANING, TOOL AND PARTS: rnd, 100 percent tampico fiber, 1-1/16 at ferrule brush din, 2-7/8 clear of block brush lg MS16746-29 (96906)		8010-221-0611	LINSEED OIL, RAW: (1 gal can) LUBRICATING OIL, GENERAL PURPOSE: VV-L-800 (81348)	PL-S
6850-965-2332	CARBON REMOVING COMPOUND: (5 gal pail) P-C-111 (81348)		9150-273-2389	4 oz can	LAW
6850-224-8656	CLEANING COMPOUND, RIFLE BORE: MIL-C-372 (81349)		9150-231-6689	1 qt can	
6850-224-6657	2 oz bottle		9150-292-9689	LUBRICATING OIL, WEAPONS: for below zero operations (1 qt can) MIL-L-14107 (81349)	
6850-224-6663	8 oz can		7920-205-1711	RAG, WIPING: cotton, (50 lb bale) DDD-R-30 class 2, grade B (81348)	
5350-221-0872	CLOTH, ABRASIVE, CROCUS: ferric oxide and quartz, jean-clothbacking, closed-coating, 9 w, 11 lg, 50-sh-sleeve, R-C-458 (81348)	CA	1005-288-3565	SWAB, SMALL ARMS CLEANING: cotton 2-1/2 sq (1,000 in pkg) 5019316 (19204)	

Section V. TROUBLESHOOTING

3-8. General

a. *Troubleshooting.* Troubleshooting shown in table 3-3 contains information for operator and organizational maintenance and serves as an aid to personnel whose responsibility it is to restore worn, damaged, or inoperative material to a satisfactory condition. This information includes both determination of causes and corrective action.

b. *Serviceability, Function Firing Test.* A certain number of rounds (dependent on method used) will be

fired in conjunction with zeroing. Malfunctions occurring during these tests should be corrected by referring to troubleshooting, table 3-3.

Note. The letters in the maintenance level column indicate the lowest level of maintenance at which corrective action can be performed. Letter C indicates operator and letter O organizational maintenance.

Table 3-3. Troubleshooting

Malfunction	Probable cause	Corrective action	Maintenance level
1. Failure to chamber	a. Worn magazine notch.	a. Replace magazine.	C
	b. Excessive friction in operating parts.	b. Clean and properly lubricate operating parts.	C
	c. Damaged ammunition.	c. Replace ammunition.	C
2. Failure of slide to cock	a. Broken sear spring.	a. Replace sear spring.	O
	b. Burs or foreign matter in sear notch.	b. Clean and remove burs.	C
3. Failure to eject	a. Insufficient gas.	a. Clean and adjust gas cylinder assembly.	C
	b. Excessive friction in operating parts .	b. Clean and properly lubricate operating parts.	C
4. Failure to extract	a. Dirty chamber.	a. Clean chamber.	C
	b. Ruptured cartridge.	b. Remove ruptured cartridge and clean chamber. (Refer to FM 23-15.)	C
	c. Broken extractor or extractor spring.	c. Replace extractor or extractor spring.	C
5. Short recoil	Gas cylinder gas ports dirty	Clean gas ports.	C
6. Failure to pull off with change lever set at F or A.	Sear spring not correctly positioned.	Reposition sear spring.	C
7. Failure to fire	a. Change lever on safe.	a. Move lever to A or F position.	C
	b. Broken firing pin.	b. Replace.	C

Table 3-3. Troubleshooting - Continued

Malfunction	Probable cause	Corrective action	Maintenance level
8. Failure to feed	c. Too much oil in firing pin recess of bolt.	c. Disassemble bolt group and wipe off excess oil.	C
	d. Excessive friction in operating parts.	d. Clean and properly lubricate operating parts.	C
	e. Weak recoil helical compression spring.	e. Replace spring.	C
	f. Faulty ammunition.	f. Replace ammunition.	C
	a. Dirty magazine.	a. Disassemble and clean.	C
	b. Defective magazine.	b. Replace.	C
9. Double feed failure to chamber	c. Dirty or corroded ammunition.	c. Remove ammunition from magazine and clean.	C
	d. Too many rounds in magazine.	d. Remove excess rounds (Maximum capacity, 20 rounds).	C
	a. Defective magazine.	a. Replace.	C
	b. Ruptured cartridge.	b. Remove ruptured cartridge and clean chamber. (Refer to FM 23-15)	C

Section VI. OPERATOR MAINTENANCE

3-9. General

This section describes operator's maintenance for rifles under normal conditions. For maintenance under adverse conditions, refer to chapter 2, section III.

3-10. Disassembly and Assembly

Note. White arrows indicate disassembly and black arrows indicate assembly.

For removal, installation and disassembly of major groups, assemblies and components refer to figures 3-1 through 3-8.

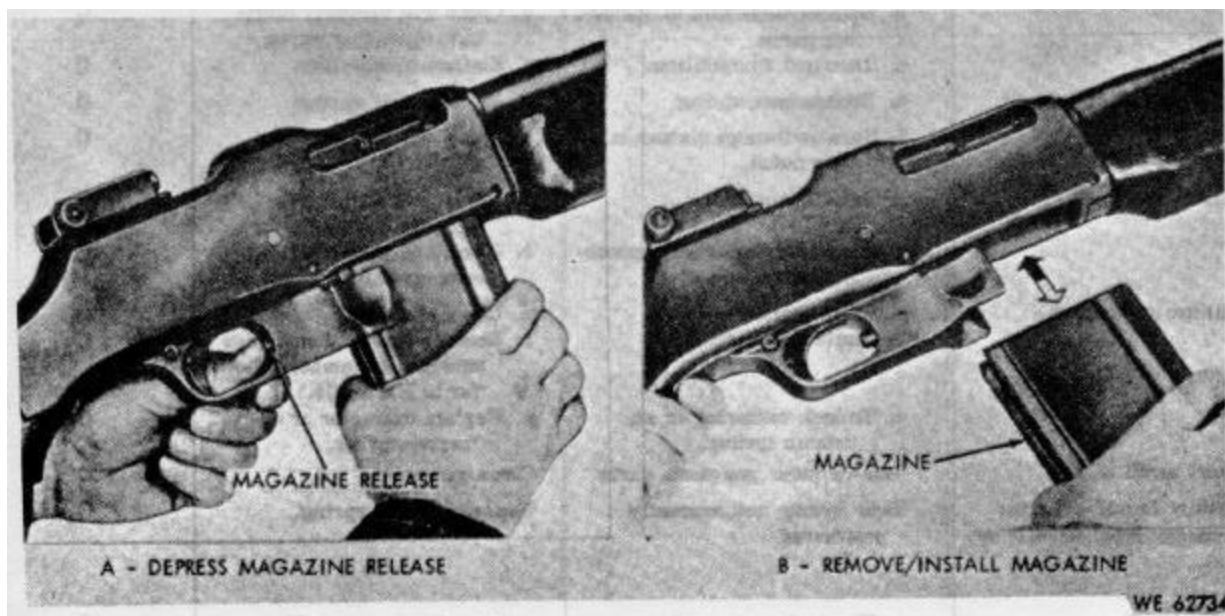

Figure 3-1. Remove/install magazine.

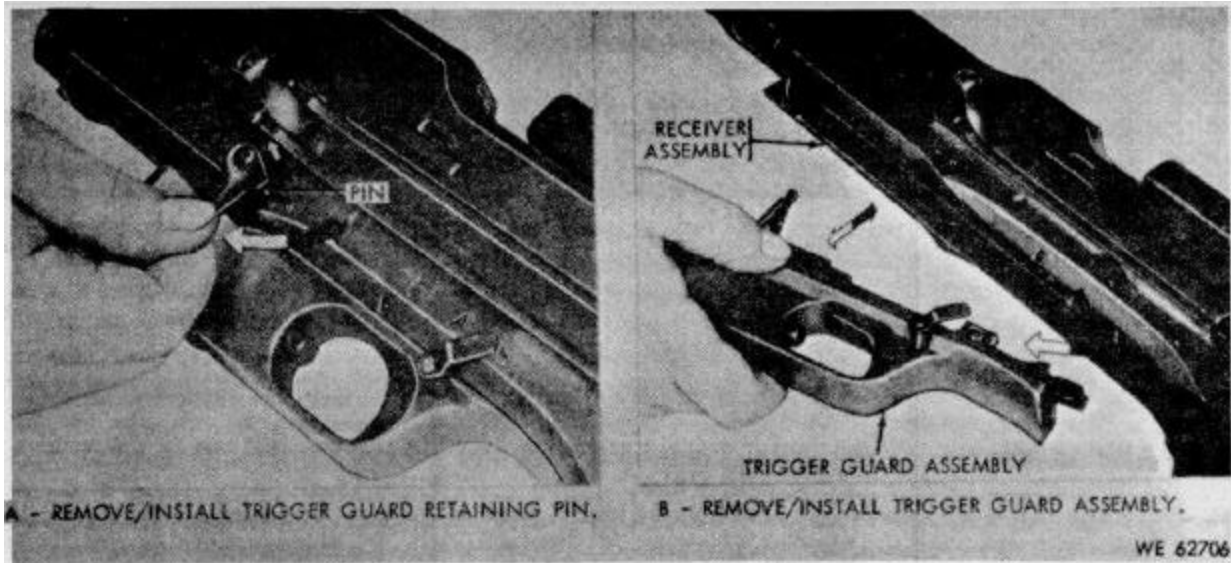

Figure 3-2. Remove/install trigger guard assembly.

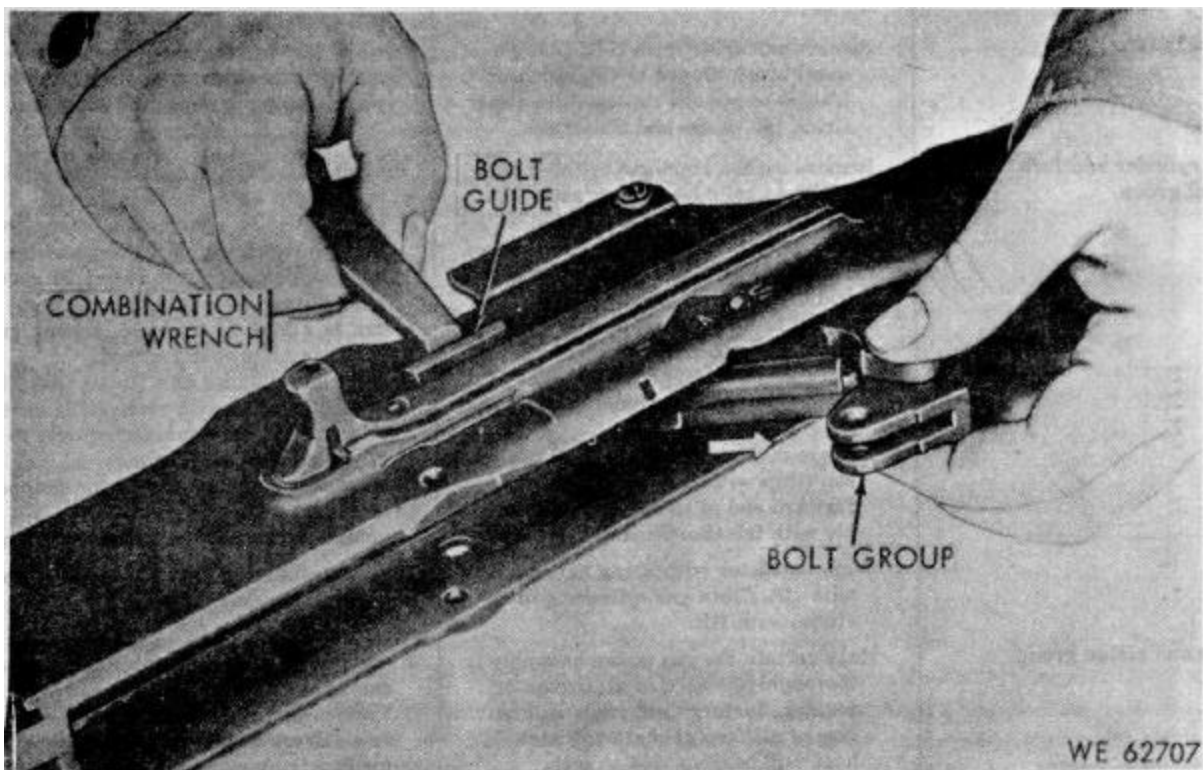

Figure 3-3. Remove/install bolt group.

Table 3-4. Operator's Guide to Maintenance

Group or assembly	Cleaning	Inspection and repair
Magazine	<p>Make sure magazine is clean, springs function properly, and the notches are not worn. Depress the magazine follower and check interior for dirty condition. If dirty, disassemble and clean interior. After assembly wipe dry.</p>	<p>Inspect magazine tube for dents, deformed or burred lips, and worn or burred catch lug. Check base for looseness on tube. Inspect follower for binding in tube under spring tension. Make sure when assembled on spring that the follower functions smoothly. Inspect spring for tension, deformation, and set. Magazine will be inspected for rust, corrosion, and other foreign matter. If any components are found defective, the magazine will be replaced as an assembly.</p>
Trigger guard assembly	<p>Wipe dirt from trigger mechanism with a clean swab or brush. Periodic disassembly of trigger guard assembly is necessary for cleaning purposes. Free movement of operating parts is contingent cleanliness and adequate lubrication. and adequate lubrication.</p>	<p>Check nose of ejector for deformation and wear. Inspect ejector lock for free movement in well of trigger guard housing. Check for damage of or distortion. Inspect nose of magazine catch for wear and to see if catch securely holds a loaded magazine. Check for wear or damage.</p>
Bolt group	<p>Wash all components and outer surfaces with a swab saturated in rifle bore cleaning compound (CR). Remove extractor from bolt. Using a small brush dipped in CR, scrub extractor to remove carbon. Also clean firing pin recess and firing pin.</p>	<p>Inspect firing pin nose for pits. Nose must be smooth and round. The firing pin should slide freely in well of bolt and protrusion of nose, from forward face of bolt, should be approximately three thirty seconds inch. Replace firing pin in bent or damaged.</p>
Gas cylinder and fore end group	<p>Remove carbon from gas cylinder body with gas cylinder reamer assembly. Using the recess cutter portion of the tool, remove carbon from the recesses at the forward end of the gas cylinder body. With drift, clean the gas ports of the barrel, gas cylinder gun (tube), gas cylinder body, and the regulator. Scrape the carbon from the face of the gas piston with the front cutting edge (fig. 3-9). Remove carbon deposit between the piston rings with the drift. Clean the forward end of the regulator assembly with the short cutter. Wipe regulator with a rag saturated with CR. Clean gas cylinder gun (tube) with CR.</p>	<p>Inspect gas cylinder regulator to see if it is too tight or too loose in gas cylinder body. In either case, when screwing the regulator, clicks are audible, but gas ports are not alined. If regulator is too tight, only one gas port can be alined. If too loose, neither gas port can be properly alined. Inspect gas cylinder gun (tube) to see if properly alined with receiver. If bent or distorted, turn gun (tube) over to direct support maintenance. Inspect fore end escutcheons for stripped threads. Examine swivel for cracks or distortion. Inspect front sling swivel loop clamp for wear and and breaks.</p>
Slide and piston group	<p>Make certain the gas piston assembly is thoroughly cleaned of all carbon or fouling. Surfaces and rings will be free of all foreign matter. Piston head will be clean and smooth.</p>	<p>Examine gas piston assembly for loose or damaged gas piston. Tighten if loose. Turn in to direct support unit if damaged. Check helical compression spring for functioning, cracks, kinks, and set. Replace if damaged.</p>

Table 3-4. Operators Guide to Maintenance - Continued

Group or assembly	Cleaning	Inspection and repair
Butt stock, buffer and actuator group		Inspect buffer head, friction cones and cups for action in buffer tube. Inspect cones for expansion seating in mating cups (cones should not seat fully in cups when at rest) and for cracks. Cups and cones must be free of burs. Inspect stock retaining sleeve for clearance with actuator tube and looseness of stop in sleeve and collar on sleeve. Check retaining sleeve lock washer for locking function and cracks.
Bipod assembly	Wipe body and outer surfaces free of dirt and other foreign matter. Dry thoroughly.	Inspect bipod body, legs, and assembly keys for burs, wear, and deformation. Check thumbscrews for stripped thread. Inspect leg joints for looseness of tubes, loose fit in body mating apertures, locking action and wear.
Rear sight assembly	<p>Note. Operator and organizational units are not authorized to remove rear sight assembly from receiver.</p> Clean all parts thoroughly. Use brush for dirty recesses and threads. Remove light rust with brush and rifle bore cleaning compound (CR). Dry all components.	Check gas cylinder tube retaining pin and trigger guard retaining pin for spring retention with depression in receiver, locking function of key in undercut in receiver (left side). If retaining pins are damaged, replace.
Barrel and receiver group	<p>Note. Operator and organizational maintenance personnel are not authorized to remove the barrel group from the receiver.</p> Brush the bore from muzzle to chamber with CR. Make sure bore is well covered. Swab out bore until clean and dry. Do not reverse direction of the brush or swabs while in the bore. Dip the brush in CR and swab out chamber until clean. Make sure that the receiver is clean of foreign matter, especially recesses. Use brush saturated with CR. Swab until clean and dry.	Inspect receiver for wear, deformation, burs, rust and foreign matter. Check for crossed threads. Check operating handle for function and free movement in its slideway.

3-11. Cleaning, Inspection and Repair

Refer to table 3-4.

3-12. Functional Check

Note. Remove magazine and bring bolt to the rear (cocked). Make certain the chamber is clear. Refer to figure 2-2.

a. A complete functional check of the rifle consists of checking the function of the rifle while the change lever is in the S (Safe), A (Fast Firing Rate), and F (Slow Firing Rate) positions.

b. The following sequence may be used for a rapid complete check. Any portion of the check may be used alone to determine the operational condition of any one specific fire selection.

(1) *S Position.* Attempt to pull the trigger. Trigger should not move nor should hammer be actuated. Necessary operating parts for firing should not be activated. Rifle should not fire. The trigger is blocked by the change lever and prevented from rising, lifting the connector, and disengaging the sear.

(2) *A Position.* Pull trigger; hammer should move. Whenever the trigger is so retracted, the connector raises the forward end

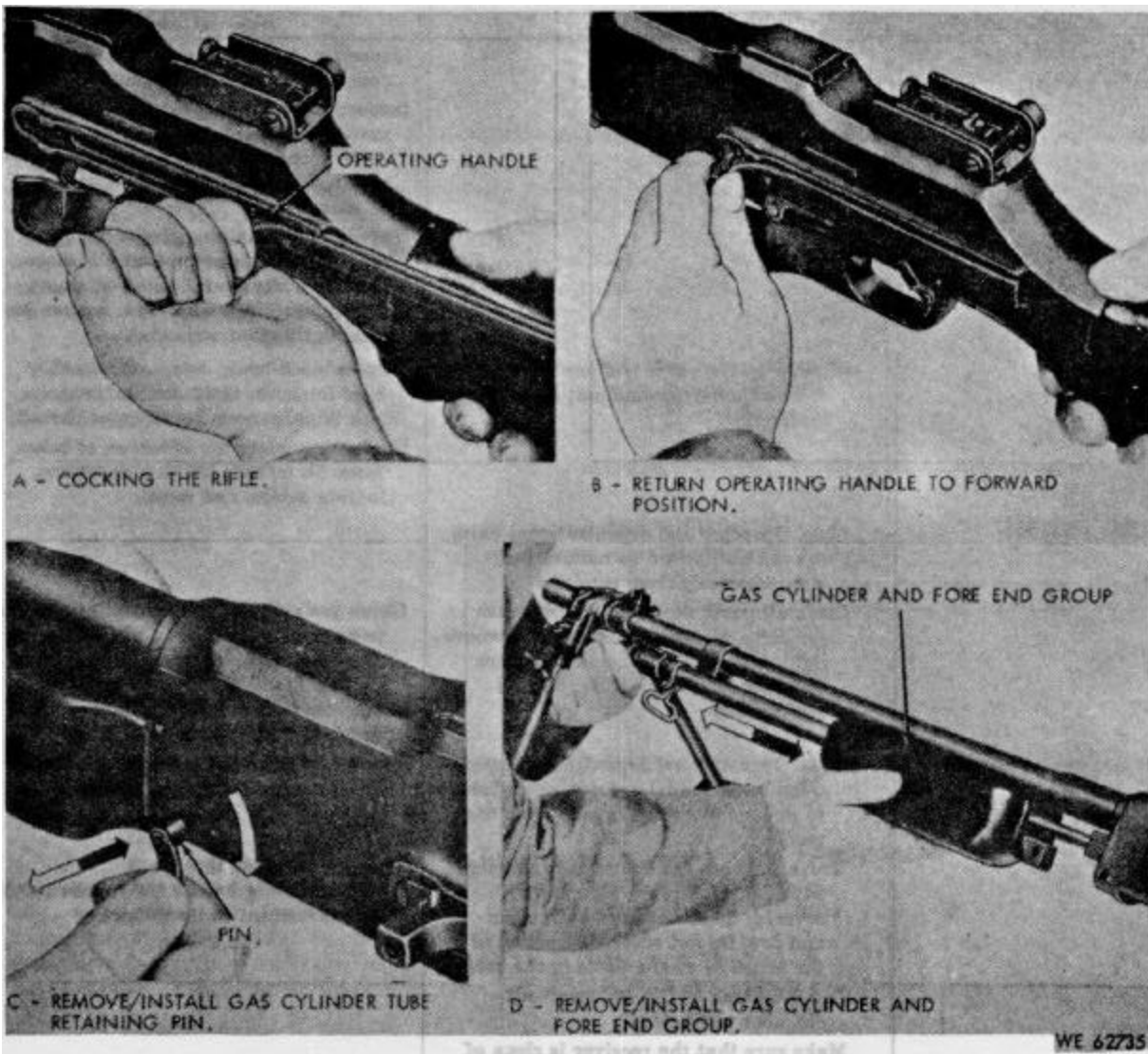

Figure 3-4. Remove/install gas cylinder and fore end group.

of the sear and sear release stop lever together and holds them up. As long as the trigger is pressed, the sear nose (rear end) is depressed and is disengaged from the sear notch on the slide. The slide assembly is then free to move forward under the force of the expanding recoil spring. As the slide moves forward, it carries the operating parts with it. When the trigger is released, both the sear and sear release stop lever should return to their normal positions.

(3) *F Position.* Slowly pull the trigger. As it becomes partially retracted, the connector raises the forward end of the sear and sear release stop together.

As the trigger is further retracted, the connector, still rising, is cammed from under front of sear by camming surface on sear carrier. Thus, the sear is free to function when acted upon by the sear release, while the rear end of the sear release stop lever is depressed to a point where it will not block the action of the sear release upon the camming surface of rear end of sear. This action produces the slow cyclic rate of fire.

(4) *Bolt in Forward Position.* Whether the change level is in the A or the F position and the bolt is closed, the trigger will be mobile, but ineffectual. The operating parts, riding

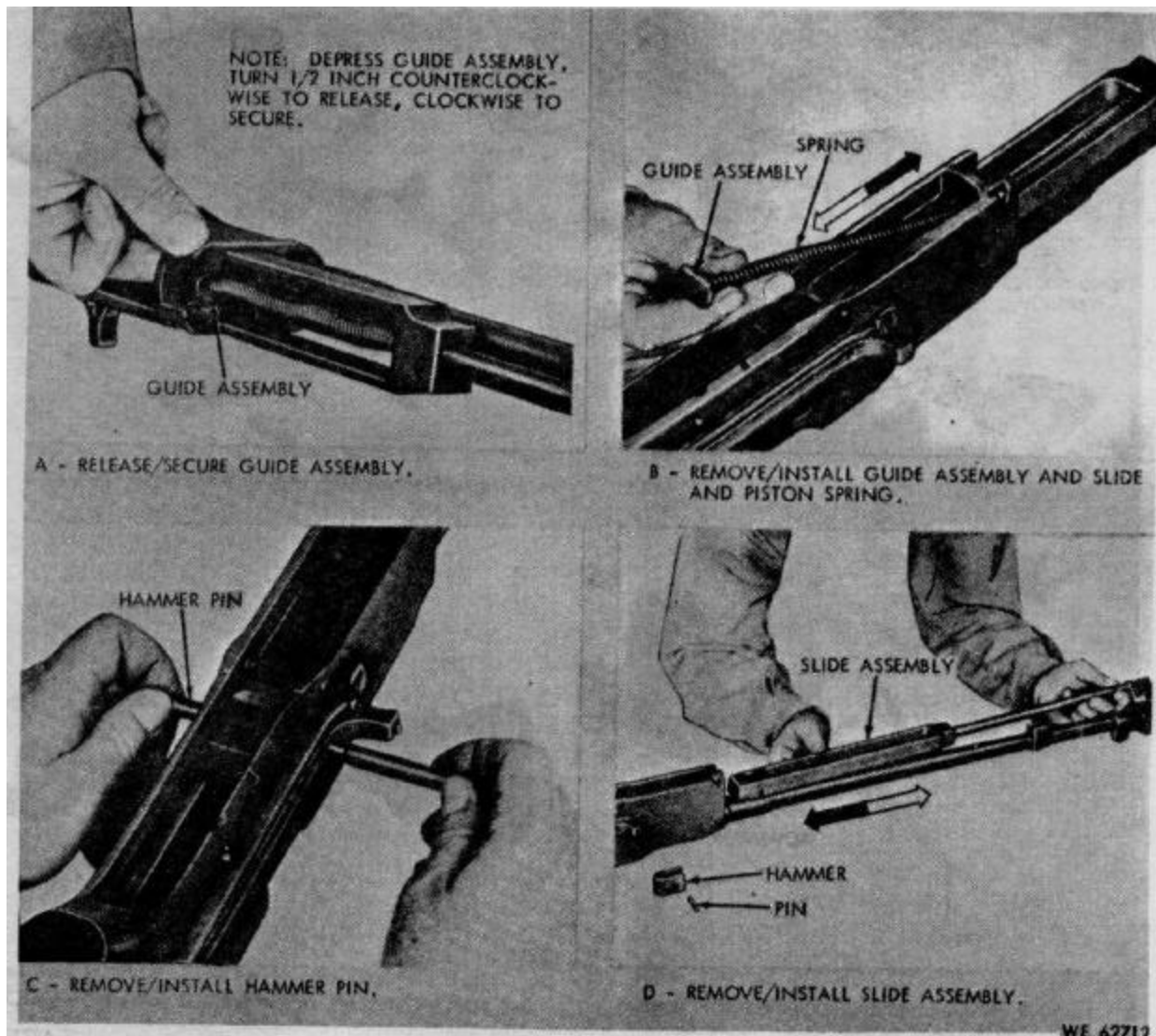

Figure 3-5. Remove/install slide and piston group.

stationary in their forward position, will remain so until the rifle has been recocked. Consequently, the firing cycle cannot be actuated. Even though the sear moves properly when the trigger is depressed, the downward

path of its notched end cannot release the absent slide. The resultant inactivity is the same as if the change lever were on S.

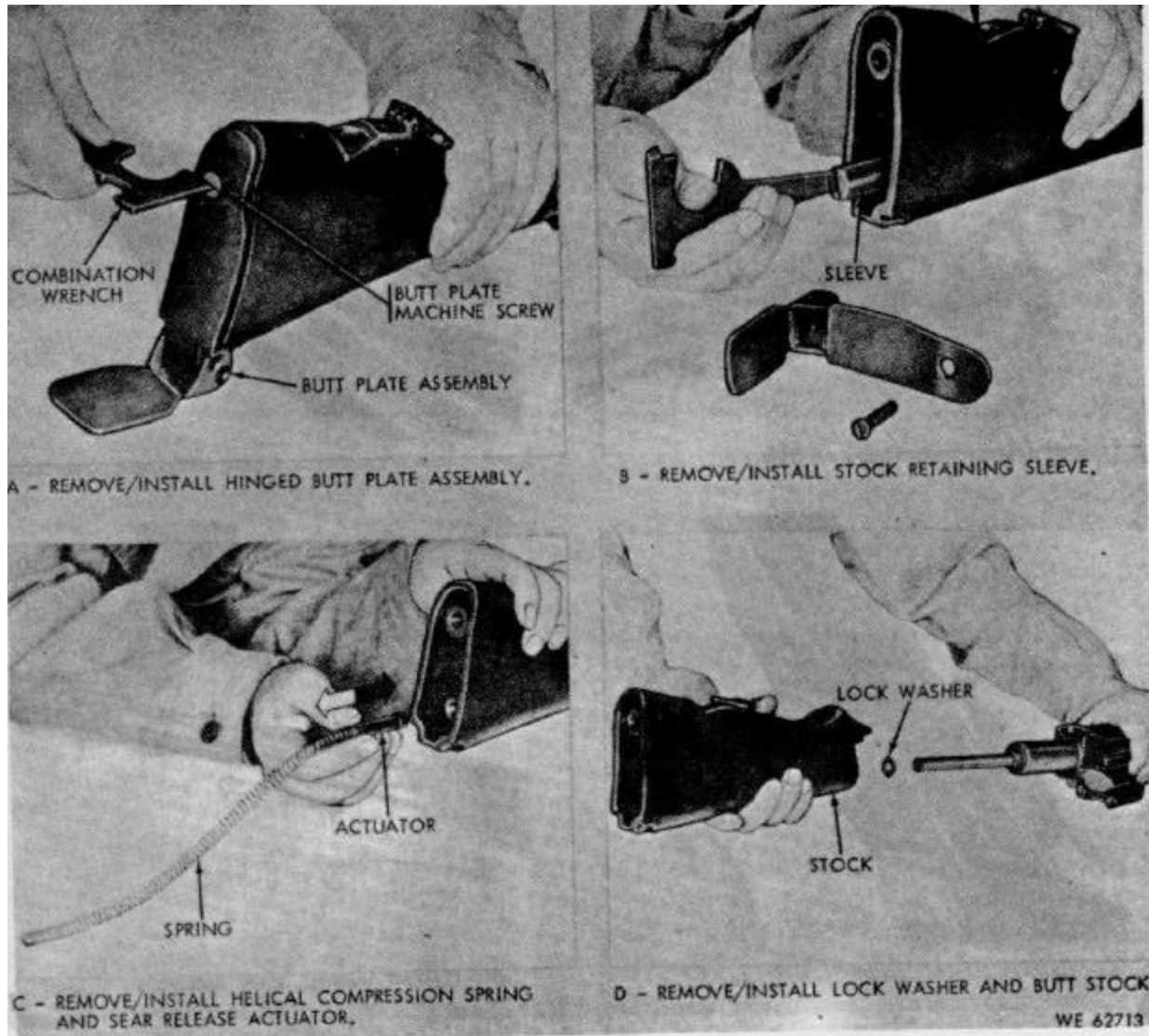

Figure 3-6. Remove/install butt stock, buffer and actuator group.

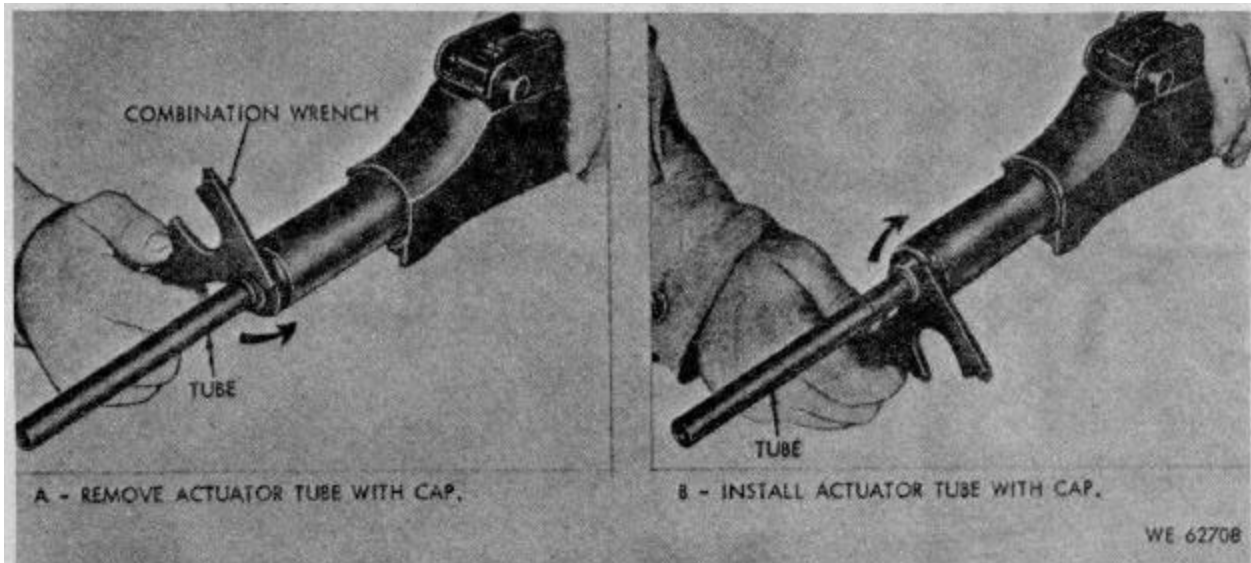

Figure 3-7. Remove/install actuator tube with cap.

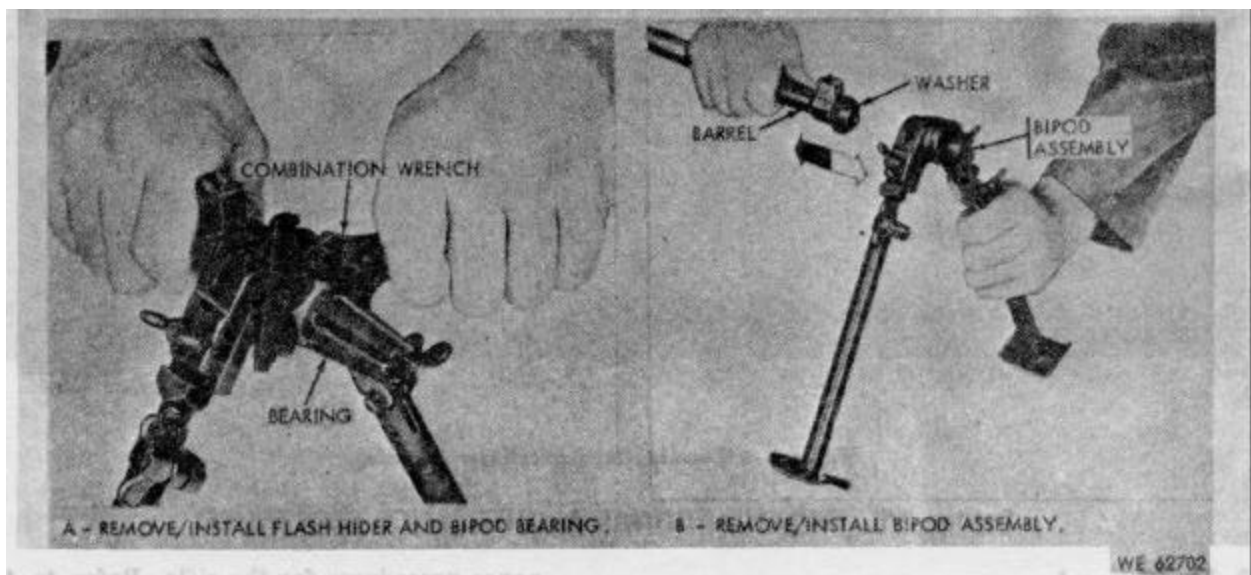

Figure 3-8. Remove/install bipod assembly.

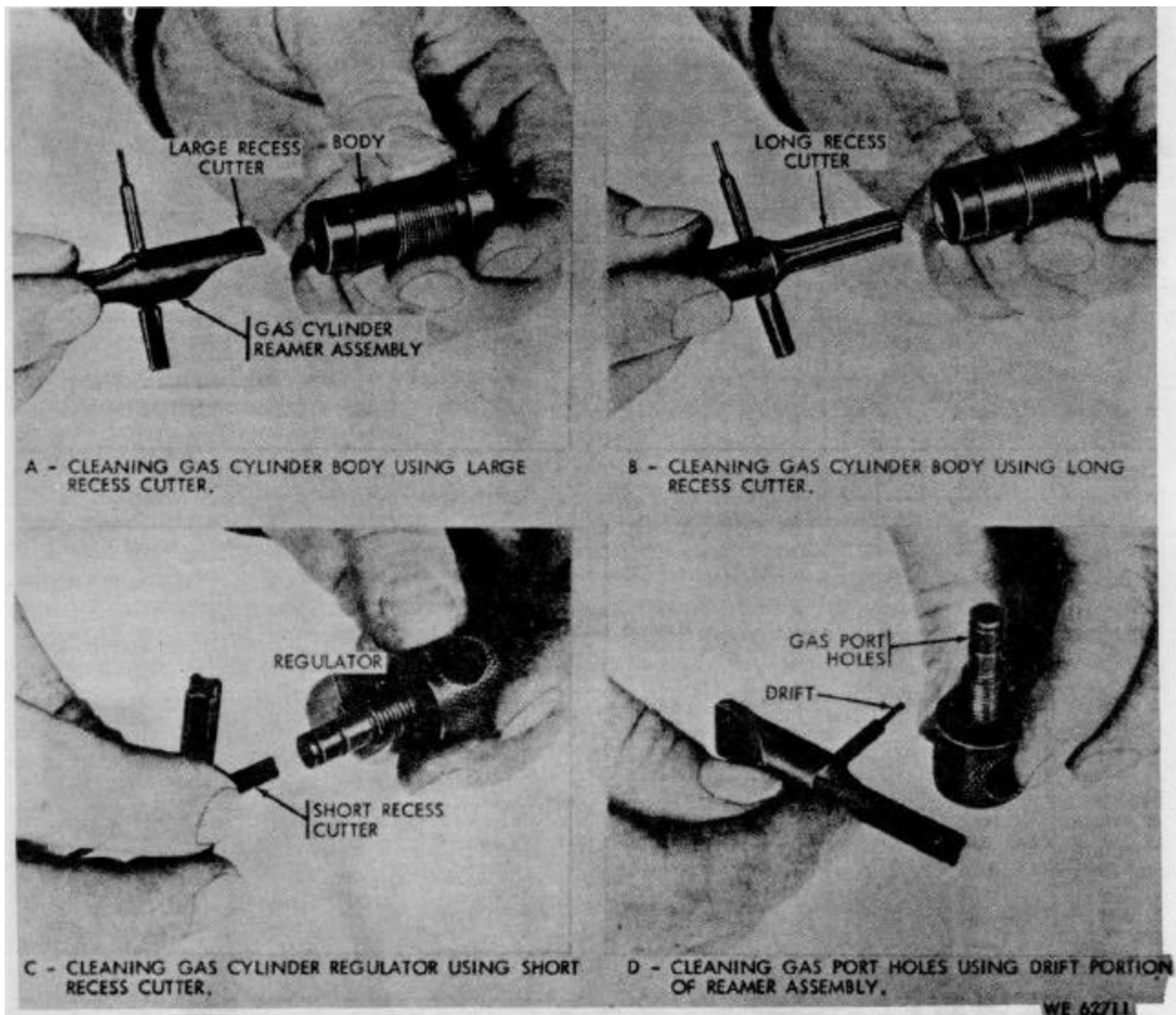

Figure 3-9. Cleaning the gas cylinder assembly.

Section VII. ORGANIZATIONAL MAINTENANCE PROCEDURES

3-13. General

procedures for the rifle. Refer to table 3-5. For lubrication instructions see paragraph 3-6.

This section describes organizational maintenance

Table 3-5. Organizational Guide to Maintenance

Group or assembly	Disassembly/assembly	Cleaning	Inspection and repair
Trigger guard assembly	C-2	Refer to table 3-4.	Examine sear and sear spring for wear and damage. Replace sear spring if necessary. Inspect top bearing surface of trigger connector where it

Table 3-5. Organizational Guide to Maintenance - Continued

Group or assembly	Disassembly/assembly	Cleaning	Inspection and repair
Bolt group	Figs 3-3 and C-3	Refer to table 3-4.	<p>contacts sear and sear release stop lever. This surface is critical for proper functioning. If camming surfaces are worn so as to affect functioning, replace trigger connector.</p> <p>Examine change lever for deformation. If worn or does not remain in selected position, turn in to direct support.</p> <p>Inspect breech bolt for looseness and excessive side play with bolt lock and pin (riveted). Check face of bolt for wear and corrosion. Inspect lower surfaces contacting bolt supports and center feed rib for wear and burs. The camming surfaces contacted by the hammer must be free of wear so that the action of the firing pin is not affected. If either the bolt or lock are found to be defective, turn in breech bolt to direct support.</p> <p>Inspect extractor spring for fracture, weak action, and looseness in extractor body. Replace if worn or damaged.</p>
Gas cylinder and fore	Fig 3-4		<p>Inspect gas cylinder for crossed end group threads, burs or wear. Replace gas cylinder assembly if body or key is worn or damaged.</p>
Slide and piston group	Fig 3-5	<p>When piston becomes locked or "frozen" in gas cylinder, submerge barrel in carbon removing compound (PC-11) until gas cylinder is covered, and soak for one hour. If this does not loosen piston, place butt stock on solid surface and, with wooden block, tap lightly on operating handle. Often considerable force is required to loosen piston. Clean rust and corrosion from piston, gas cylinder, and gun (tube). Remove all cleaning solvent with a clean cloth.</p> <p>Warning. Avoid skin contact. The compound should be washed off thoroughly with running water if it comes in contact with the skin. A good lanolin base cream after exposure to compound, is helpful. The</p>	<p>Inspect guide assembly for deformation, fit and retention in shoulder of receiver. Defective guide assemblies will be turned in to the direct support unit.</p> <p>Inspect slide for deformation of side rails which could cause binding with operating mechanism or receiver, badly dented rear end (indicating frozen buffer), and worn hammer pin hole. If defective, slide and piston assembly will be turned in as a group to direct support.</p>

Table 3-5. Organizational Guide to Maintenance - Continued

Group or assembly	Disassembly/assembly	Cleaning	Inspection and repair
Butt stock, buffer and actuator group	Figs 3-6 and 3-7	<p>use of use of gloves and protective equipment is recommended.</p> <p>All metal components will be cleaned of all foreign matter with dry cleaning solvent (SD). Cups and cones must be free of burs.</p> <p>If buffer head becomes frozen in tube, soak buffer tube and components in carbon removing compound (PC-111). Use hard wood plug to drive out buffer and components from tube.</p> <p>If cones and cups become frozen, soak in dry cleaning solvent (SD) and tap edges of cup until loose. Clean parts thoroughly.</p> <p>Butt plate assembly will be free of all foreign matter and hinging action perform smoothly.</p>	<p>Inspect actuator tube for wear and dents. Check tube for looseness in buffer cap. Tube should be smooth and polished inside; actuator should slide freely in actuator tube. Defective tubes will be turned in to direct support.</p> <p>Inspect stocks for cracks, scoring, and stripped threads in the butt plate and swivel screw holes. Check hinged butt plate assembly for deformation and free action. The hinged butt plate must work freely when it is rotated and must be held securely in its open position by the bearing ball in the inner butt plate. Defective stocks and butt plate assemblies will be turned in to direct support.</p>
Bipod assembly Rear sight assembly	Fig 3-8	Refer to table 3-4.	<p>Defective or unserviceable parts will be turned in to direct support.</p> <p>Inspect parts for damage, burs, rust, foreign matter in recesses, deformation, and for free action with mating parts. Check rear sight base for looseness on receiver and windage scale for wear and damage.</p> <p>Inspect screws for stripped threads and screw holes for damage.</p> <p>Inspect rear sight windage click plunger and elevating screw in rear sight leaf for function and wear. If either is defective turn damaged part(s) in to direct support.</p>
Barrel and receiver group		Refer to table 3-4.	<p>Barrel will be checked for deformation, alinement in receiver, crossed threads, rust, corrosion, wear, burs and foreign substances in gas port and extractor aperture. Alinement of barrel with receiver must be exact in order that rear end of gas cylinder tube will fit mating slot in receiver and front sight will aline properly.</p>

Table 3-5. Organizational Guide to Maintenance-Continued

Group or assembly	Disassembly/assembly	Cleaning	Inspection and repair
			<p>Inspect barrel for ruptured cartridge case. To remove cartridge case, use ruptured cartridge case extractor 7790352. (See FM 23-15.)</p> <p>Inspect buffer tube for dents or damage. Severe dents will cause weakness in well of tube; if dented, tube will be turned in to direct support.</p> <p>Examine bore of barrel using barrel reflector (fig 3-10). If not deformed or appears free of bulges and large pits, and if lands are sharp and uniformly distinct, barrel is serviceable.</p> <p>Inspect gas cylinder bracket for looseness on barrel, alignment of gas port with barrel port, and for worn or burred T-cuts. If bracket is loose on barrel or if pin is missing, turn barrel assembly in to direct support.</p> <p>Plunger will also be inspected for function and free movement in its well.</p> <p>Inspect bolt guide for sustained functioning with bolt, looseness with spring, and weak action of spring.</p>

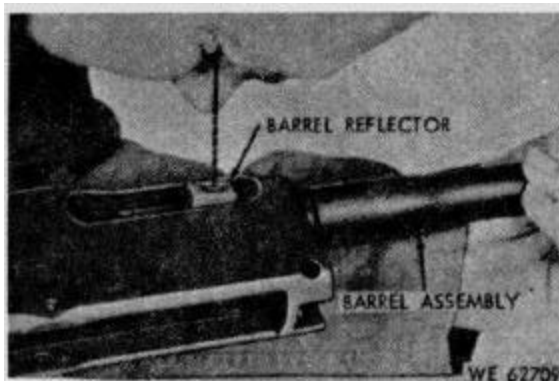

Figure 3-10. Inspection of barrel bore.

CHAPTER 4

MAINTENANCE OF MATERIEL USE IN CONJUNCTION
WITH MAJOR ITEM

4-1. General

The winter trigger kit is issued or requisitioned only by special authorization of the area commander. Initial installation will be accomplished by direct support maintenance.

4-2. Organizational Maintenance

- a. *Inspection.* Inspect winter safety for cracks or

distortion. Make certain safety will function properly within firing mechanism.

- b. *Cleaning and Repair.* The winter trigger kit (fig. C-6) will be disassembled for purposes of cleaning and replacement of unserviceable parts. For cleaning and lubricating instructions, refer to tables 3-4, 3-5 and paragraph 3-6. For a listing of authorized repair parts, refer to appendix C.

CHAPTER 5

AMMUNITION

5-1. General

The ammunition for the Browning automatic rifle is classified as small-arms ammunition and is issued in the form of a complete round. A complete round (cartridge) consists of all the components necessary to fire the weapon once, that is, projectile (bullet), cartridge case, propellant, and primer.

5-2. Classification

a. Cartridges for the rifle are classified as centerfire cartridges. In a centerfire cartridge the primer is located in a small well or pocket in the center of the cartridge case head.

b. The cartridges for this weapon are classified and identified according to type and model as follows:

- (1) Tracer, M1
- (2) Ball, M2
- (3) Armor Piercing (AP), M2
- (4) Armor Piercing Incendiary (API), M14
- (5) Ball, Frangible, M22
- (6) Tracer, M25
- (7) Dummy, M40
- (8) Blank, M1909

5-3. Identification

a. *General.* Ammunition for this weapon is identified completely by packing and marking, including the ammunition lot number, on original jacking containers. When ammunition is removed from its original packing container, the full identity of the ammunition, including the lot number, nomenclature, and model designation shall be maintained with the ammunition.

b. *Identification.* The various cartridges can be visually identified as itemized in table 5-1.

Table 5-1. Identification of Caliber .30 Cartridges

Type of cartridge	Identification
Tracer, M1	Red Bullet Tip
Armor Piercing, M2	Black Bullet Tip

Table 5-1. Identification of Caliber .30 Cartridges-Continued

Type of cartridge	Identification
Ball, M2	None
Armor Piercing Incendiary, M14	Aluminum Bullet Tip
Ball Frangible, M22	Green and White Bullet Tip
Tracer, M25	Orange Bullet Tip
Dummy, M40	Six Longitudinal Corrugations
Blank, M1909	No Bullet, Crimped Mouth

c. *Marking.* Ammunition for the subject weapon has the manufacturer's identification and year of manufacture impressed on the head of the cartridge case. The year is denoted by the last digits of the calendar year.

5-4. Care, Handling and Preservation

a. This ammunition is not dangerous to handle. It is packed to withstand conditions normally encountered in the field. Moisture resistant ammunition boxes are used to provide protection during shipment and storage; however, care must be taken to prevent this packing from becoming damaged. All damaged packing must be repaired or replaced immediately with careful attention given to the transfer of all markings to the new parts.

b. Ammunition boxes should be opened carefully as they are to be used as long as they are serviceable.

c. Ammunition boxes should not be opened until the ammunition is required for use. Ammunition removed from airtight containers for extended periods of time, particularly in damp climate, is apt to corrode, thereby rendering the ammunition unserviceable.

d. Cartridges should be protected from high temperatures and prolonged exposure to the direct rays of the sun. Such exposure is likely to affect ballistic performance of the cartridges. The combination of high temperatures and a humid atmosphere is particularly

detrimental to the stability of the propellant and to the tracer mixture in tracer ammunition.

e. Cartridges should be kept clean and free of foreign matter. If cartridges get wet or dirty, they should be wiped off at once. If light corrosion forms on cartridges, it should be wiped off with a clean dry cloth. If a cartridge case becomes so corroded that any amount of metal is eaten away, it is dangerous to fire and should not be fired. Cartridges should not be polished to make them look better or brighter.

f. The use of oil or grease on cartridges is prohibited. Oil or grease might cause injurious abrasives to collect in weapons or produce excessive and hazardous chamber pressures when fired.

g. Whenever practicable, ammunition should be stored under cover. This applies particularly to tracer ammunition.

h. When it is necessary to store ammunition in open storage, raise it on dunnage at least six inches from the ground and cover it with a double thickness of paulin, leaving enough space for the free circulation of air through the stack. Suitable trenches should be dug to prevent water from running under the stock.

i. When ammunition is stored, it should be segregated by caliber or millimeter, type, and ammunition lot.

j. When only a part of a box of ammunition is issued or used, the ammunition remaining in the ammunition box should be protected by firmly fastening the cover.

k. Ammunition removed from the original pack should be tagged or marked in order to preserve the ammunition lot number.

l. For additional instructions in the care, handling, preservation, and destruction of ammunition, refer to TM 9-1300-206.

5-5. Authorized Cartridges

Refer to paragraph 5-2b for authorized cartridges.

5-6. Preparation for Firing

a. After removal from packing materials, these cartridges are ready to be used.

b. Cartridges which are not used will be returned to their original packings. (Such cartridges will be used first in subsequent firings so as to reduce stocks of opened packings.) If the original packings are not utilized, the boxes in which the ammunition is stored should be appropriately marked with the nomenclature of the cartridges and the ammunition lot number.

CHAPTER 6

DESTRUCTION TO PREVENT ENEMY USE

6-1. General

a. Destruction of the rifle when subject to capture or abandonment in the combat zone, will be undertaken only when, in the judgment of the commander concerned, such action is necessary. The authority for ordering the destruction of equipment is vested in divisional or higher commanders, who may delegate authority to subordinate commanders when the situation requires. If destruction is resorted to, the equipment must be so badly damaged that it cannot be restored to a usable condition in the combat zone either by repair or cannibalization. The reporting of the destruction of

equipment is to be done through command channels.

b. Priorities for destruction of parts are:

- (1) Bolt group
- (2) Barrel and receiver group
- (3) Rear sight assembly
- (4) Bipod assembly

c. The same priority, for destruction of component parts of the major item necessary to render that item inoperable, must be given to the destruction of similar components in spare parts storage areas.

APPENDIX A

REFERENCES

A-1. Publication Indexes

The following indexes should be consulted frequently for the latest changes or revisions of references given in this appendix and for new publications relating to materiel covered in this manual.

Military Publications:

Index of Administrative Publication	DA Pam 310-1
Index of Army Films, Transparencies, GTA Charts and Recording	DA Pam 108-1
Index of Blank Forms	DA Pam 310-2
Index of Doctrinal, Training, and Organizational Publications	DA Pam 310-6
Index of Supply Catalogs and Supply Manuals (excluding types 7, 8, and 9)	DA Pam 310-6
Index of Technical Manuals, Technical Bulletins, Supply Manuals (types 7, 8, and 9), Supply Bulletins, and Lubrication Orders	DA Pam 310-4
U.S. Army Equipment Index of Modification Work Orders	DA Pam 310-7

A-2. Forms

DA Form 2028, Recommended Changes to DA Publications

A-3. Other Publications

a. *General.*

Accident Reporting and Records	AR 385-40
Administrative Storage of Equipment	TM 740-90-1
Army Equipment Record Procedures	TM 38-750
Authorized Abbreviations and Brevity Codes	AR 320-60
Basic Cold Weather Manual	FM 31-70
Browning Automatic Rifle Cal. .30, M1918A2	FM 23-15
Dictionary of United States Army Terms (short title: AD)	AR 320-5
Intensive Management of Secondary Items	AR 710-50

b. *Ammunition.*

Ammunition, General	TM 9-1900
Care, Handling, Preservation, and Destruction of Ammunition.....	TM 9-1300-206
Disposal of Supplies and Equipment:	
Ammunition	AR 755-140-1
Explosives and Demolitions	FM 5-25

c. *Logistics.*

Malfunctions Involving Ammunition and Explosives	AR 700-1300-8
--	---------------

d. *Inspection and Maintenance.*

Cleaning of Ordnance Materiel.....	TM 9-208-1
------------------------------------	------------

e. *Training.*

Military Training Management	FM 21-5
Techniques of Military Instruction	FM 21-6

APPENDIX B

MAINTENANCE ALLOCATION CHART

Section I. INTRODUCTION

B-1. General

The maintenance allocation chart indicates specific maintenance operations performed at proper maintenance levels. Deviation from maintenance operations allocated in the chart is authorized only upon approval of the Commanding Officer.

B-2. Maintenance Functions

Maintenance functions will be limited to and defined as follows:

a. *Inspect.* To determine serviceability. of an item by comparing its physical, mechanical and electrical characteristics with established standards.

b. *Test.* To verify serviceability and to detect electrical or mechanical failure by use of test equipment.

c. *Service.* To clean, to preserve, to charge, and to add fuel, lubricants, cooling agents, and air.

d. *Adjust.* To rectify to the extent necessary to bring into proper operating range.

e. *Align.* To adjust specified variable elements of an item to bring to optimum performance.

f. *Calibrate.* To determine the corrections to be made in the readings of instruments or test equipment used in precise measurement. Consists of the comparison of two instruments, one of which is a certified standard of known accuracy, to detect and adjust any discrepancy in the accuracy of the instrument being compared with the certified standard.

g. *Install.* To set up for use in an operational environment such as an emplacement, site, or vehicle.

h. *Replace.* To replace unserviceable items with serviceable like items.

i. *Repair.* Those maintenance operations necessary to restore an item to a serviceable condition through correction of material damage or a specific

failure. Repair may be accomplished at each category of maintenance.

j. *Overhaul.* Normally, the highest degree of maintenance performed by the Army in order to minimize time work in process is consistent with quality and economy of operation. It consists of that maintenance necessary to restore an item to completely serviceable condition as prescribed by maintenance standards in technical publications for each item of equipment. Overhaul normally does not return an item to like new, zero mileage, or zero hour condition.

k. *Rebuild.* The highest degree of materiel maintenance. It consists of restoring equipment as nearly as possible to new condition in accordance with original manufacturing standard. Rebuild is performed only when required by operational considerations or other paramount factors .and then only at the depot maintenance category. Rebuild reduces to zero the hours or miles the equipment, or component thereof, has been in use.

l. *Symbols.* The uppercase letter placed in the appropriate column indicates the lowest level at which that particular maintenance function is to be performed.

B-3. Explanation of Format

Purpose and use of the format are as follows:

a. *Column 1, Group Number.* Lists group numbers, the purpose of which is to identify components, assemblies, subassemblies and modules with the next higher assembly.

b. *Column 2, Functional Group.* Lists the noun names of components, assemblies, subassemblies and modules on which maintenance is authorized.

c. *Column 3, Maintenance Functions.* Lists the various categories of maintenance to be performed on the weapon.

d. *Use of Symbols.* Explanation of the use of symbols in maintenance function, column 3, is as follows:

Code	Explanation
C	Operator/crew
O	Organizational maintenance
F	Direct support maintenance
H	General support maintenance
D	Depot maintenance

e. *Column 4, Tools and Equipment.* This column will be used to specify, by code, those tools and test equipment required to perform the designated function.

f. *Column 5, Remarks.* Self-explanatory.

Note. Columns not utilized are considered not applicable.

**Section II. MAINTENANCE ALLOCATION CHART FOR RIFLE,
CALIBER .30, AUTOMATIC, BROWNING, M1918A2**

(1) Group no.	(2) Functional group	(3) Maintenance function											(4) Tools and equipment	(5) Remarks	
		Inspect	Test	Service	Adjust	Align	Calibrate	Install	Replace	Repair	Overhaul	Rebuild			
1.	Magazine	C	-	C	-	-	-	C	C	C	-	D	-		
2.	Trigger Guard Assembly	C	-	C	-	-	-	C	F	C	-	D	-		
3.	Bolt Group	C	-	C	-	-	-	C	-	C	-	D	-		
4.	Gas Cylinder and Fore End Group	C	-	C	-	-	-	C	-	O	-	D	-		
5.	Slide and Piston Group	C	-	C	-	-	-	C	-	C	-	D	-		
6.	Butt Stock, Buffer and Actuator Group	C	-	C	-	-	-	C	-	F	-	D	-		
7.	Bipod Assembly	C	-	C	-	-	-	C	-	F	-	D	-		
8.	Rear Sight Assembly	C	-	C	-	-	-	F	F	F	-	D	-		
9.	Barrel and Receiver Group	C	-	C	-	-	-	-	-	F	-	D	-		

**APPENDIX C
BASIC ISSUE ITEMS LIST
AND
ITEMS TROOPS INSTALLED OR AUTHORIZED LIST
AND
ORGANIZATIONAL MAINTENANCE REPAIR PARTS AND
AND
SPECIAL TOOLS LISTS**

Section I. INTRODUCTION

C-1. Scope

This appendix lists basic issue items, items troop installed or authorized, repair parts and special tools required by the crew/operator for operation and required for the performance of organizational maintenance of the rifle M1918A2.

C-2. General

This basic issue items, items troop installed or authorized, repair parts and special tools list is divided into the following sections:

a. *Basic Issue Items List - Section II.* A list, in alphabetical sequence, of items absolutely essential for operation of the end item, which are furnished with and must be turned in with the end item.

b. *Items Troop Installed or Authorized List - Section III.* A list, in alphabetical sequence, of items required by the operator for sustained operation of the end item. These discretionary items will be requisitioned by the unit in accordance with its mission requirements. They may accompany the end item, but are not subject to be turned in with it.

c. *Repair Parts-Section V.* A list of repair parts authorized for the performance of maintenance at the organizational level in figure and item number sequence.

d. *Special Tools, Test and Support Equipment-Section VI.* A list of special tools, test and support equipment authorized for the performance of maintenance at the organizational level.

e. *Federal Stock Number and Reference Number Index-Section VII.* A list of Federal stock numbers in ascending numerical sequence, followed by a list of reference numbers appearing in all the listings, in ascending alphanumeric sequence, cross-reference to the illustration figure number and item number.

C-3. Explanation of Columns

The following provides an explanation of columns in the tabular lists in Sections II through VI.

a. *Source Maintenance, and Recoverability Codes (SMR).*

(1) *Source Code.* Indicates the selection status and source for the listed item. Source codes used are:

Code	Explanation
P	Repair parts which are stocked in or supplied from the GSA/DSA, or Army supply system, and authorized for use at indicated maintenance categories.
P2	Repair parts which are procured and stocked for insurance purposes because the combat or military essentiality of the end item dictates that a minimum quantity be available in the supply system.
M	Repair parts which are not procured or stocked but are manufactured at indicated maintenance categories.
A	Assemblies which are not procured or stocked as such but are made up of two or more units. Such component units carry individual FSN's and descriptions are procured and stocked and can be assembled at indicated maintenance categories.
X	Parts and assemblies which are not procured or stocked and the mortality of which is normally below that of the applicable end item or component. The failure of such part or assembly should result in retirement of the end item from the supply system.
X1	Repair parts which are not procured or stocked. The requirement for such items will be filled by use of the next higher assembly or component.
X2	Repair parts which are not stocked. The indicated maintenance category requiring such repair parts will attempt to obtain through cannibalization; if not obtainable through cannibalization, such repair parts will be requisitioned with supporting justification through normal supply channels.
G	Major assemblies that are procured with PEMA funds for initial issue only to be

Code	Explanation
	used as exchange assemblies at DSU and GSU level. These assemblies will not be stocked above DSU and GSU level or returned to Depot supply level.

(2) *Maintenance Code*. Indicates the lowest category of maintenance authorized to install the item. The maintenance level codes are:

Code	Explanation
C	Operator or crew
O	Organizational

(3) *Recoverability Code*. Indicates whether unserviceable items should be returned for recovery or salvage. Items not coded are expendable. The recoverability codes are:

Code	Explanation
R	Applied to repair parts (assemblies and components) which are considered economically repairable at Direct and General support maintenance levels. When the maintenance capability to repair these items does not exist, they are normally disposed of at the GS level. When supply considerations dictate some of these repair parts may be listed for automatic return to supply for Depot level repair as set forth in AR 710-50. When so listed, they will be replaced by supply on an exchange basis.
S	Repair parts and assemblies which are economically repairable at DSU and GSU activities and normally are furnished by supply on an exchange basis. When items are determined by a GSU to be uneconomically repairable, they will be evacuated to a depot for evaluation and analysis before final disposition.
T	High dollar value recoverable repair parts which are subject to special handling and are issued on an exchange basis. Such repair parts are normally repaired or overhauled at depot maintenance activities.
U	Repair parts specifically selected for salvage by reclamation units because of precious metal content, critical materials, high dollar value reusable casings, or castings.

No Code Parts will be considered expendable. Indicated.

b. *Federal Stock Number*. Indicates the Federal stock number assigned to the item and will be used for requisitioning purposes.

c. *Description*. Indicates the Federal item name and any additional description of the item required. The abbreviation "w/e" when used as a part of the nomenclature indicates that the Federal stock number includes all armament, equipment, accessories, and repair parts issued with the item. A part number or other reference number is followed by the applicable five-digit Federal supply code for manufacturers in parentheses.

d. *Unit of Measure (U/M)*. Indicates the standard or basic quantity by which the listed item is used in performing the actual maintenance function. This measure is expressed by a two-character alphabetical abbreviation, e.g., ea, in, pr, etc, and is the basis used to indicate quantities. When the unit of measure differs from the unit of issue, the lowest unit of issue that will satisfy the required units of measure will be requisitioned.

e. *Quantity Furnished with Equipment (Basic Issue Items Only)*. Indicates the quantity of the item furnished with the equipment.

f. *Quantity Authorized (Items Troop Installed or Authorized Only)*. Indicates the quantity of the item authorized to be used with the equipment.

g. *Quantity Incorporated in Unit*. Indicates the quantity of the item used in that functional group/assembly. A "V" appearing in this column in lieu of a quantity indicates that no specific quantity is applicable, e.g., shims, spacers, etc.

h. *15-Day Organizational Maintenance Allowances*.
 (1) The allowance columns are divided into four subcolumns. Indicated in each subcolumn opposite the first appearance of each item is the total quantity of items authorized for the number of equipments supported. Subsequent appearances of the same item will have the letters "REF" in the allowance columns. Items authorized for use as required but not for initial stockage are identified with an asterisk in the allowance column.

(2) The quantitative allowances, for organizational level of maintenance represents one initial prescribed load for a 15-day period for the number of equipments supported. Units and organizations authorized additional prescribed loads will multiply the number of prescribed loads authorized by the quantity of repair parts reflected in the appropriate density column to obtain the total quantity of repair parts authorized.

(3) Organizational units providing

maintenance for more than 100 of these equipments shall determine the total quantity of parts required by converting the equipment quantity to a decimal factor by placing a decimal point before the next to last digit of the number to indicate hundredths, and multiplying the decimal factor by the parts quantity authorized in the 51-100 allowance column. Example, authorized allowance for 51-100 equipments is 12; for 140 equipments multiply 12 x 1.40 or 16.80 rounded off to 17 parts required.

(4) Subsequent changes to allowances will be limited as follows: No change in the range of items is authorized. If additional items are considered necessary, recommendations should be forwarded to Commanding General, Headquarters, U.S. Army Weapons Command, ATTN: AMSWE-SMM-SA, Rock Island, Illinois 61201, for exception or revision to the allowance list. Revisions to the range of items authorized will be made by the U.S. Army Weapons Command based upon engineering experience, demand data, or TAERS information.

i. Illustration.

(1) Figure Number. Indicates the figure number of the illustration in which the item is shown.

(2) Item Number. Indicates the callout number used to reference the item in the illustration.

Note. Items shown on illustration, but not listed, are for disassembly purposes only.

C-4. How to Locate Repair Parts

a. When Federal stock number or reference number is unknown:

(1) *First.* Using the table of contents determine the functional group or assembly, within which the repair part belongs. This is necessary since illustrations are prepared for functional groups and assemblies, and listings are divided into the same groups.

(2) *Second.* Find the illustration covering the

functional group or assembly to which the repair part belongs.

(3) *Third.* Identify the repair part on the illustration and note the illustration figure and item number of the repair part.

(4) *Fourth.* Using the repair parts listing, find the functional group or assembly to which the repair part belongs and locate the illustration figure and item number noted on the illustration.

b. When Federal stock number or reference number is known:

(1) *First.* Using the Index of Federal Stock Numbers and Reference Numbers, find the pertinent Federal stock number or reference number. This Index is in ascending FSN sequence followed by a list of reference numbers in alpha-numeric sequence, cross-referenced to the illustration figure number and item number.

(2) *Second.* Using the Repair Part Listing, find the functional group or assembly of the repair part and the illustration figure number and item number referenced in the index of Federal Stock Numbers and Reference Numbers.

C-5. Abbreviations

Abbreviation	Explanation
gnd	ground
S	steel
sh	sheet
stk	stock

C-6. Federal Supply Code for Manufacturers

Code	Explanation
19204.....	Rock Island Arsenal
19205.....	Springfield Armory

Section II. BASIC ISSUE ITEMS LIST

(1) Federal stock No.	(2) Description <i>Reference number & mfr. code</i> <i>Usable on code</i>		(3) Unit of meas	(4) Qty furn with equip	(5) Illustration	
					(a) Fig. No.	(b) Item No.
1005-716-2547	CAP: MAGAZINE 7162547 (19204)		EA	1	C-4	5

(1) Source, maint. and Recov. code			(2)	(3)		(4)	(5)	(6)	(7)	
Source	Maint.	Recov	Federal Stock No.	Description		Unit of meas	Qty inc. in unit	Qty. furn. with equip	Illustration	
				Reference Number & Mfr. Code	Usable on Code				(a) Fig no.	(b) Item no.
			4993-652-9950	EXTRACTOR, RUPTURED CAR- TRIDGE CASE: 7790352 (19205)		EA		1	C-5	7
			1005-550-7918	FILLER: MAGAZINE 5507913 (19205)		EA		1	C-5	2
			1005-781-2902	HANDLE: CARRYING 7312902 (19205)		EA		1	C-1	5
			1005-793-6761	HANDLE ASSEMBLY: CLEANING ROD 7266115 (19204)		EA		1	C-5	10
			4983-08-0340	REAMER ASSEMBLY, GAS CYLINDER CLEANER: 7268211 (19205)		EA		1	C-5	4
			1005-726-6109	ROD SECTION, CLEANING, SMALL ARMS: 7266109 (19205)		EA		5	C-5	8
			1005-714-9749	SLING, SMALL ARMS: 7149749 (19204)		EA		1	C-5	1
			1005-726-6110	SWAB HOLDER SECTION, SMALL ARMS CLEANING ROD: 7266110 (19204)		EA		1	C-6	9
			4933-726-6450	WRENCH, COMBINATION: HOOK, SPANNER AND SCREWDRIVER 7266450 (19205)		EA		1	C-5	8

Section III. ITEMS TROOP INSTALLED OR AUTHORIZED LIST

(1) Federal stock No.	(2) Description <i>Reference Number & mfg. code</i> <i>Usable on code</i>	(3) Unit of meas	(4) Qty auth
1005-610-8828	BRUSH, CLEANING, SMALL ARMS: M6 CHAMBER 6108828 (19204)	EA	1
1005-556-4174	BRUSH, CLEANING, SMALL ARMS: BORE 5564174 (19204)	EA	1
1005-652-8362	BRUSH SET, CLEANING, SMALL ARMS: CHAMBER 6528362 (19204)	EA	1
1005-716-2547	CAP: MAGAZINE 7162547 (19204)	EA	18
1005-550-6573	CASE, SMALL ARMS CLEANING ROD: 5506573 (19204)	EA	1
1005-722-8907	ENVELOPE: FABRIC, 2-BUTTON, 3X 4-7/8 7228907 (19204)	EA	1
4933-652-9950	EXTRACTOR, RUPTURED CARTRIDGE CASE: 7790352 (19204)	EA	1
1005-550-7913	FILLER: MAGAZINE 5507913 (19204)	EA	1
1005-793-6761	HANDLE ASSEMBLY: CLEANING ROD 7266115 (19204)	EA	1
1005-556-4076	MAGAZINE, CARTRIDGE: 5564076 (19204)	EA	18
4933-508-0340	REAMER ASSEMBLY, GAS CYLINDER CLEANER: 7268211 (19204)	EA	1
1005-726-6109	ROD SECTION, CLEANING, SMALL ARMS: 7266109 (19204)	EA	1
1005-726-6110	SWAB HOLDER SECTION, SMALL ARMS CLEANING ROD: 7266110 (19204)	EA	1
4933-726-6450	WRENCH, COMBINATION: HOOK, SPANNER AND SCREW- DRIVER 7266450 (19204)	EA	1

Section IV. PRESCRIBED LOAD ALLOWANCE

DELETED IAW CHANGE 1

Section V. ORGANIZATIONAL REPAIR PARTS LIST

(1) Source, maint. and Recov. code			(2)	(3)	(4)	(5)	(6)				(7)	
Source	Maint	Recov.	Federal stock No.	Description Reference Number & Mfr Code	Unit of meas	Qty inc in unit	15-Day organizational maintenance alw				Illustration	
							(a) 1-5	(b) 6-20	(c) 21-50	(d) 51-100	(a) Figure No.	(b) Item No.
COMPONENTS AND ASSEMBLIES												
P	C		1005-556-4076	MAGAZINE, CARTRIDGE: 5564076 (19205)	EA	1	2	6	12	22	C-1	1
P	C		1005-556-4074	PIN: RETAINING, GAS CYLINDER 5564074 (19205)	EA	1	*	2	2	2	C-1	3
P	C		1005-601-9680	PIN, RETAINING, TRIGGER GUARD: 6019680 (19205)	EA	1	*	2	2	2	C-1	3
P	O	R	1005-347-4257	CYLINDER ASSEMBLY, GAS: 7267819 (19205)	EA	1	*	*	*	2	C-1	4
P	C		1005-515-3128	SPRING, HELICAL, COMPRES- SION: S, 0.0430 DIA STK 0.325 OD, 130 COILS 5153128 (19205)	EA	1	*	2	2	3	C-1	5
TRIGGER GUARD ASSEMBLY												
P	C		1005-515-3130	SPRING, HELICAL, COMPRES- SION: S, 0.350 DIA STK, 0.36 OD, COILS 5153130 (19205)	EA	1	*	2	2	3	C-2	1
P	C		531.5-502-2238	PIN, STRAIGHT, HEADLESS: S, GND, 0.1245 IN, MIN DIA, 0.1255 IN, MAX DIA X 1.015-.010 LG 5022238 (19204)	EA	2	*	2	2	3	C-2	2
P	C		1005-601-9662	SPRING, SEAR: 6019662 (19205)	EA	1	*	2	2	3	C-2	3
P	C		1005-614-7490	SPRING: CHANGE AND STOP LEVER 6147490 (19205)	EA	1	*	*	2	2	C-2	4
P	O		1005-601-9636	CONNECTOR: TRIGGER 6019636 (19205)	EA	1	*	*	2	2	C-2	5
BOLT GROUP												
P	C		1005-601-9652	PIN: FIRING 6019652 (19204)	EA	1	*	*	2	2	C-3	1
P	C		1005-620-1267	EXTRACTOR: CARTRIDGE CASE 5509090 (19204)	EA	1	*	*	2	2	C-3	2
P	C		1005-502-2202	SPRING, EXTRACTOR: 5022202 (19206)	EA	1	*	2	2	3	C-3	3
MATERIAL REQUIRED FOR COLD WEATHER CLIMATES												
THE FOLLOWING ITEMS ARE ISSUED OR REQUISITIONED ONLY BY SPECIAL AUTHORIZATION OF THE AREA COMMANDER												
			1005-777-1370	KIT, WINTER TRIGGER: FOR ARCTIC HANDWEAR 5910521 (19204)	EA	--	*	*	*	*	C-6	

(1) Source, maint. and Recov. code			(2)	(3)	(4)	(5)	(6)				(7)	
Source	Maint	Recov.	Federal stock No.	Description Reference Number & Mfr Code Usable on Code	Unit of meas	Qty inc in unit	15-Day organizational maintenance alw				Illustration	
							(a) 1-5	(b) 6-20	(c) 21-50	(d) 51-100	(a) Figure No.	(b) Item No.
P	X1		5305-990-6435	COMPOSED OF: TRIGGER ASSEMBLY, WINTER: 7790809	EA	2	*	*	*	*	C-6	1
	O			SCREW, TAPPING, THREAD FORMING 7791415 (19205)								
P	O		1005-010-5022	WASHER HINGE RETAINING: TRIGGER ASSY 7791237 (19205)	EA	2	*	*	*	*	C-6	3
P	O		1005-778-0581	SAFETY, WINTER: 7790904 (19205)	EA	1	*	*	*	*	C-6	4

Section VI. SPECIAL TOOLS, TEST AND SUPPORT EQUIPMENT

(1) Source, maint. and Recov. code			(2)	(3)	(4)	(5)	(6)				(7)	
Source	Maint	Recov.	Federal stock No.	Description Reference Number & Mfr Code Usable on Code	Unit of meas	Qty inc in unit	15-Day organizational maintenance alw				Illustration	
							(a) 1-5	(b) 6-20	(c) 21-50	(d) 51-100	(a) Figure No.	(b) Item No.
				TOOLS AND EQUIPMENT FOR UNIT REPLACEMENT								
			1005-55-9738	BAG: CANVAS SPARE PARTS 5559738 (19205)	EA	--	*	*	*	*	C 4	3
			1005-556-4174	BRUSH, CLEANING, SMALL ARMS: BORE 5564174 (19204)	EA	--		2	3	5	C-4	8
			1005-610-8828	BRUSH, CLEANING, SMALL ARMS: MG, CHAMBER 6108826 (19206)	EA	--	*	2	2	3	C-4	4
			1005-652-8362	BRUSH SET, CLEANING, SMALL ARMS: CHAMBER 6528362 (19205)	EA	--	*	2	2	3	C-4	7
			1005-716-2547	CAP: MAGAZINE 7162547 (19205)	EA	--	*	2	3	5	C-4	5
			1005-550-6573	CASE, SMALL ARMS CLEAN- ING ROD: 5506573 (19204)	EA	--	*	*	*	*	C--4	1
			1005-556-4177	COVER: FRONT SIGHT 5564177 (19205)	EA	--	*	*	2	2	C-4	6
			1005-722-8907	ENVELOPE: FABRIC, 2 BUT- TON, 3 X 4-7/8 7228907 (19205)	EA	--	*	*	*	2	C-4	2
			4933-652-9950	EXTRACTOR, RUPTURED CARTRIDGE CASE: 7790352 (19205)	EA	--	*	*	2	2	C-5	7
			1005-550-7913	FILLER: MAGAZINE 5507913 (19205)	EA	--	*	*	2	2	C-5	2
			1005-731-2902	HANDLE: CARRYING 7312902 (19205)	EA	--	*	*	2	2	C-5	5
			1005-793-6761	HANDLE ASSEMBLY: CLEAN- ING ROD 7266115 (19204)	EA	--	*	2	2	2	C-5	10
			4933-508-0340	REAMER ASSEMBLY, GAS CYLINDER CLEANER: 7268211 (19205)	EA	--	*	*	2	2	C-5	4
			1005-726-6109	ROD SECTION, CLEANING, SMALL ARMS: 7266109 (19205)	EA	--	*	2	3	5	C-5	8
			1005-714-9749	SLING, SMALL ARMS: 7149749 (19204)	EA	--	*	2	2	3	C-5	1
			1005-726-6110	SWAB HOLDER SECTION, SMALL ARMS CLEANING ROD: 7266110 (19204)	EA	--	*	2	2	3	C-5	9
			1005-2884-565	SWAB, SMALL ARMS CLEAN- ING: COTTON, 2-1/2 SQ (1,000 IN PACKAGE) 5019316 (19204)	PG	--	*	*	2	2	-	-
			4933-726-6450	WRENCH, COMBINATION: HOOK, SPANNER AND SCREWDRIVER 7266450 (19205)	EA	--	*	*	2	2	C-5	3

(1) Source, maint. and Recov. code			(2)	(3)	(4)	(5)	(6)				(7)	
Source	Maint	Recov.	Federal stock No.	Description Reference Number & Mfr Code Usable on Code	Unit of meas	Qty inc in unit	15-Day organizational maintenance alw				Illustration	
							(a) 1-5	(b) 6-20	(c) 21-50	(d) 51-100	(a) Figure No.	(b) Item No.
				ORGANIZATIONAL MAINTENANCE TOOLS AND EQUIPMENT (FOR ARMORERS USE) THE 16 DAY LEVEL IS NOT APPLICABLE.								
			4933-628-9700	REFLECTOR, GUN BARREL: 7790138 (19205)	EA	--	*	*	*	2	C-5	6
				MAINTENANCE SUPPLIES								
			8020-244-0153	BRUSH ARTISTS: METAL, FERRULE, FLAT, CHISEL EDGES, 7/16 W, 1-1/8 LG EXPOSED BRISTLE	EA	--	*	*	*	*		
			7920-205-2401	BRUSH, CLEANING, TOOL AND PARTS: RND, 100 PER- CENT TAMPICO FIBER, 1-1/16 AT FERRULE BRUSH DIA 2-7/8 CLEAR OF BLOCK BRUSH LG	EA	--	*	*	*	*		
			6850-966-2332	CARBON REMOVING COM- POUND: (P-C-111) (5 GAL PAIL) CLEANING COMPOUND, RIFLE BORE: (CR)	GL	--	*	*	*	*		
			6850-224-6656	2 OZ CAN	OZ	--	*	*	*	*		
			6850-224-6657	1 OZ CAN	OZ	--	*	*	*	*		
			6850-224-6658	1 QT CAN	QT	--	*	*	*	*		
			6850-224-6663	1 GAL CAN	GL	--	*	*	*	*		
			6350-221-0872	CLOTH, ABRASIVE CROCUS: FERRIC OXIDE AND QUARTZ, JEAN-CLOTH- BACKING, CLOSED-COAT, 9 W, 11 LG, 50 SH-SLEEVE, (CA) DRY CLEANING SOLVENT: (SD)	SV	--	*	*	*	*		
			6850-664-6685	1 QT CAN	QT	--	*	*	*	*		
			6850-281-1985	1 GAL CAN	GL	--	*	*	*	*		
			8010-221-0611	LINSEED OIL, RAW: (1 GAL CAN) LUBRICATING OIL, GENERAL PURPOSE: (PL SPECIAL)	GL	--	*	*	*	*		
			9150-273-2389	4 OZ CAN	OZ	--	*	*	*	*		
			9150-231-6689	1 QT CAN LUBRICATING OIL, WEAP- ONS: (LAW) FOR BELOW ZERO OPERATIONS	QT	--	*	*	*	*		
			9150-664-0038	4 OZ CAN	OZ	--	*	*	*	*		

(1) Source, maint. and Recov. code			(2) Federal stock No.	(3) Description Reference Number & Mfr Code Usable on Code	(4) Unit of meas	(5) Qty inc in unit	(6) 15-Day organizational maintenance alw				(7) Illustration	
Source	Maint	Recov.					(a) 1-5	(b) 6-20	(c) 21-50	(d) 51-100	(a) Figure No.	(b) Item No.
			9150-292-9689 7920-205-1711	1 QT CAN RAG, WIPING: COTTON, FOR GENERAL PURPOSE USE (50 LB BALE)	QT LB	-- --	*	*	*	*		

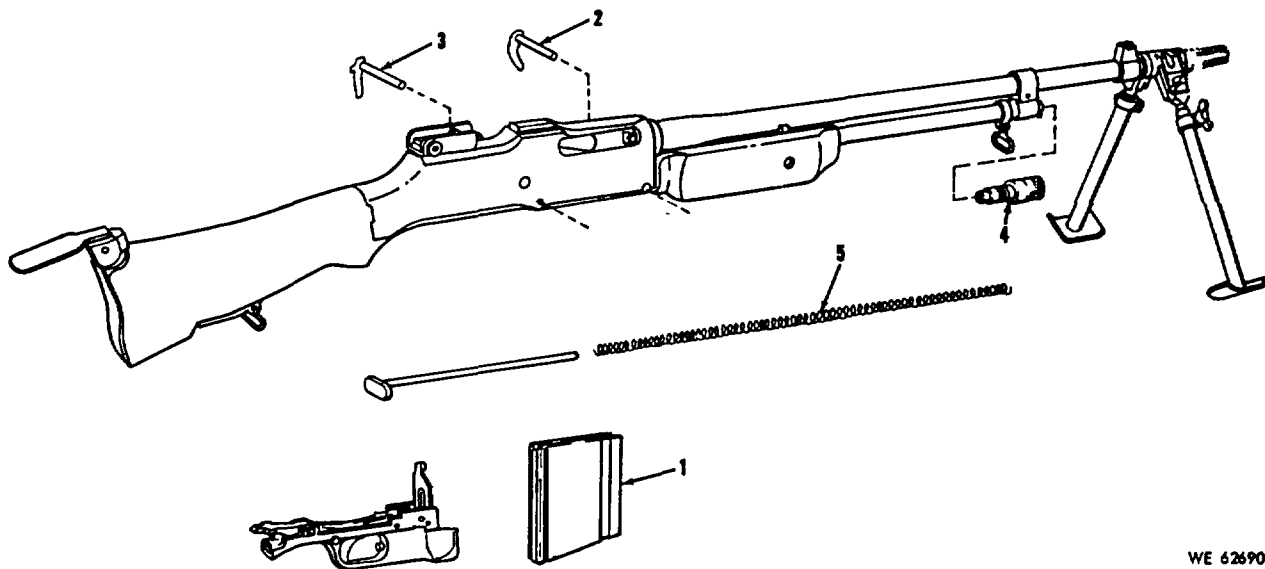
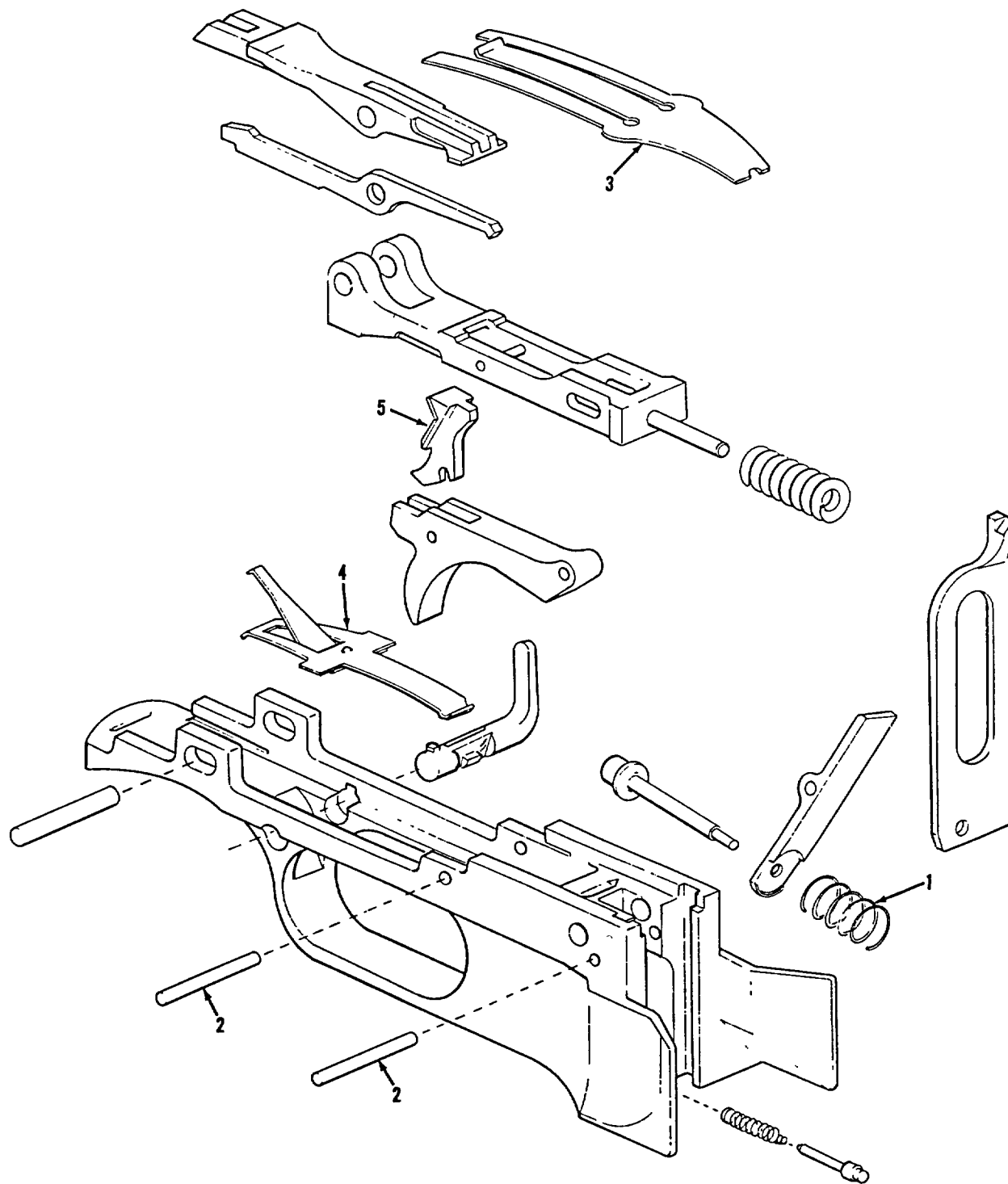

Figure C-1. Components and assemblies-Caliber .30 Browning Automatic Rifle M1918A2-partial exploded view.



WE 62714

Figure C-2. Trigger guard assembly-exploded view.

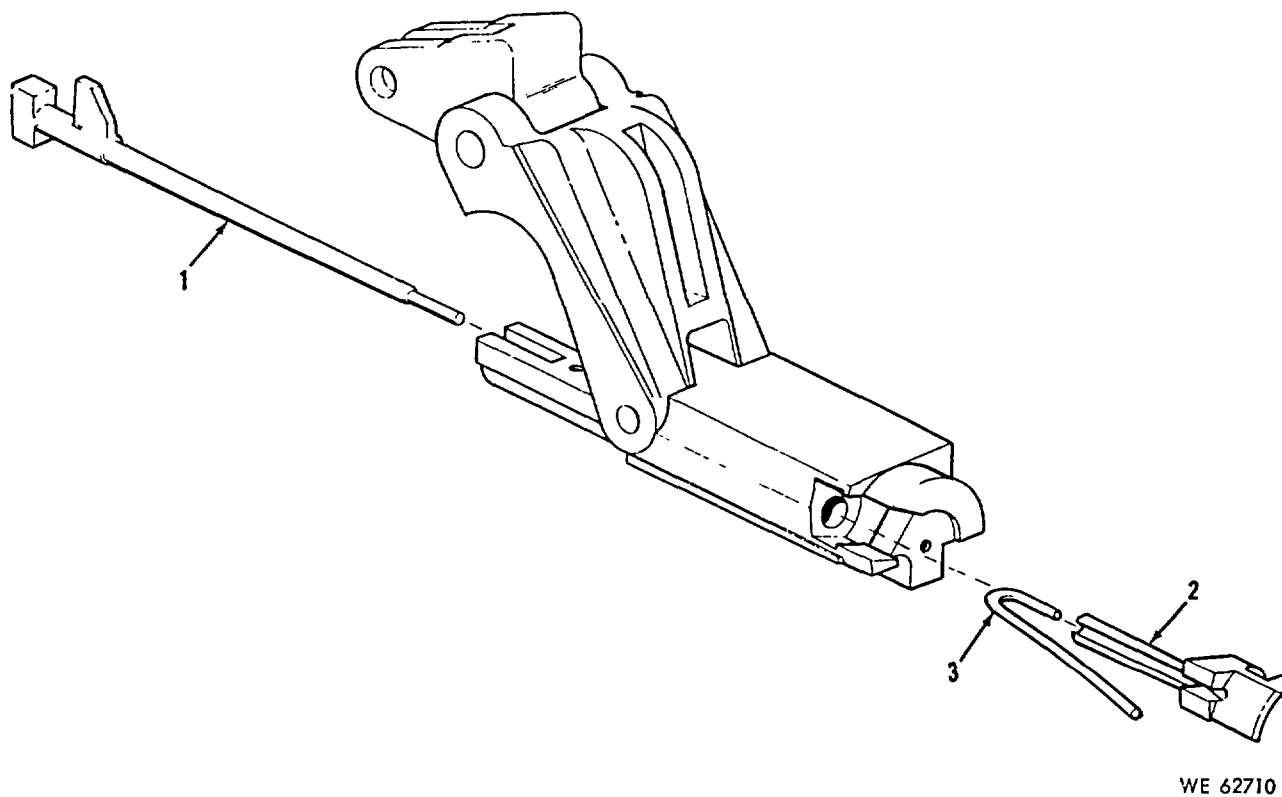

Figure C-3. Bolt group-partial exploded view.

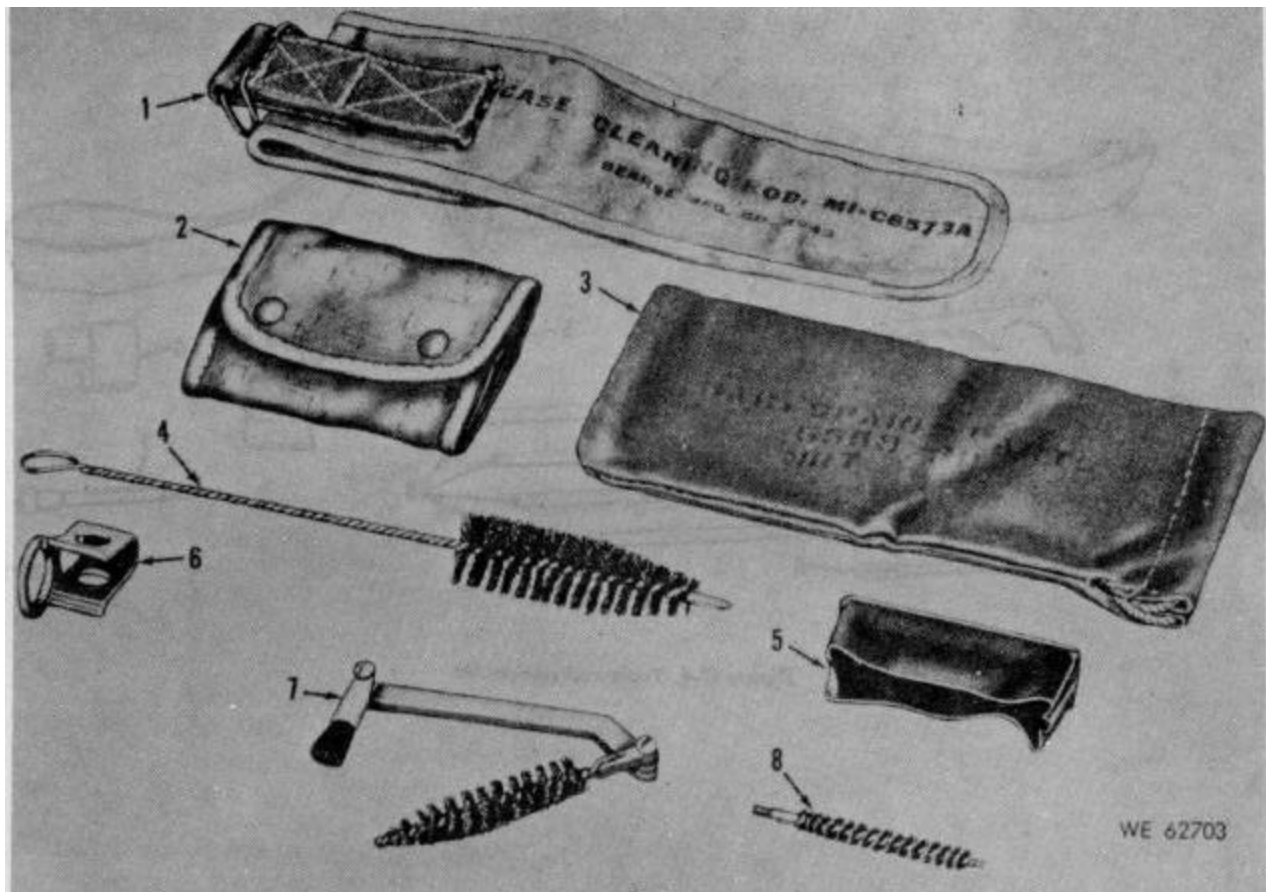
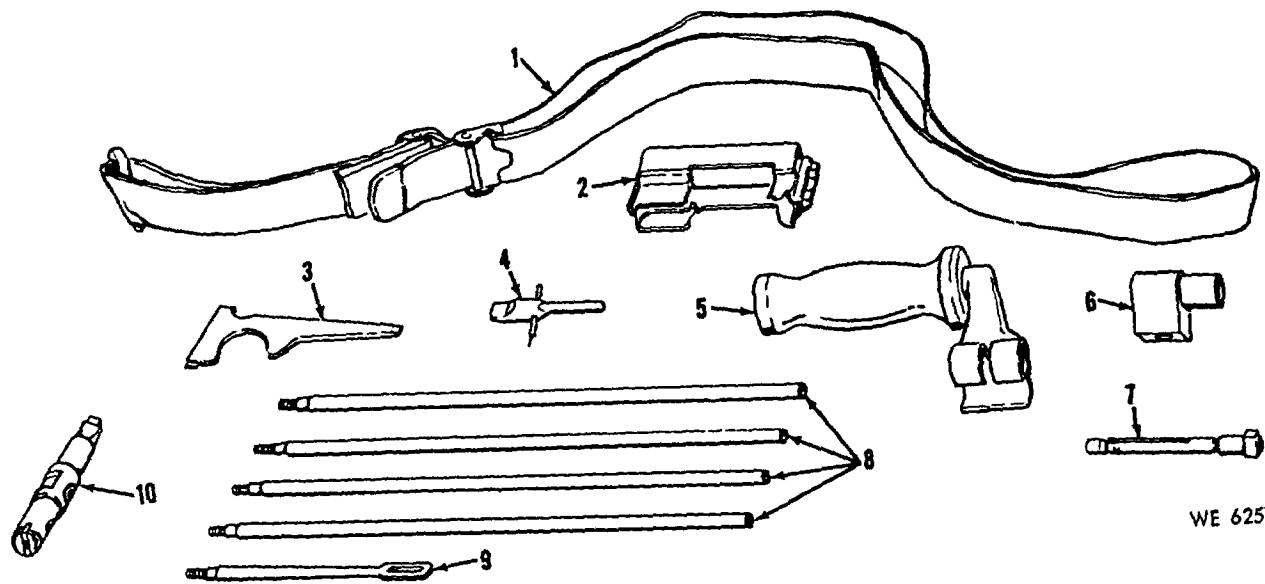
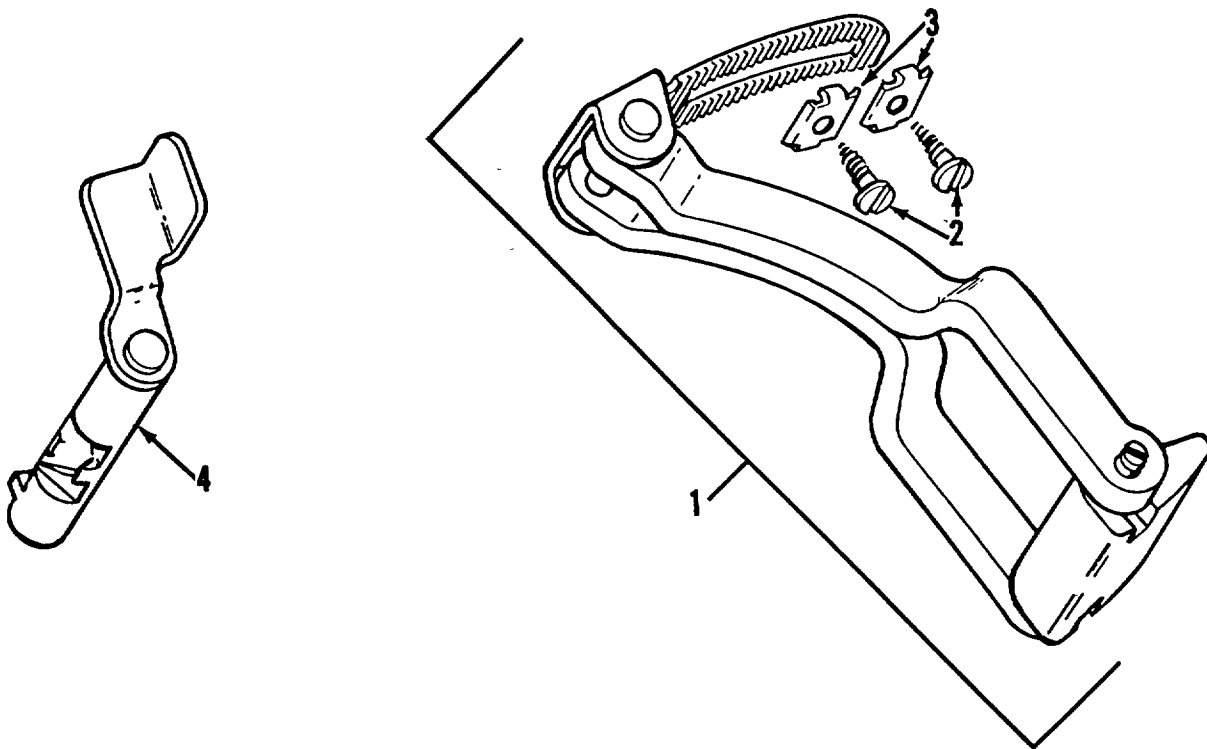

Figure C-4. Tools and equipment.



WE 62571

Figure C-5. Tools and equipment.



WE 62704

Figure C-6. Winter trigger kit-exploded view.

**Section VII. FEDERAL STOCK NUMBER AND REFERENCE NUMBER
CROSS-REFERENCE TO FIGURE AND ITEM NUMBER**

Stock Number	Figure No.	Item No.	Stock Number	Figure No.	Item No.
1005-010-5022	C-6	8	1005-620-1267	C-8	2
1005-347-4257	C-1	4	1005-652-8362	C-4	2
1005-502-2202	C-8	8	1005-714-9749	C-6	1
1005-515-3128	C-1	5	1005-716-2547	C-4	5
1005-515-3130	C-2	1	1005-722-8907	C-4	2
1005-550-6573	C-4	1	1005-726-6109	C-5	8
1005-550-7913	C-6	2	1005-726-6110	C-5	9
1005-555-9738	C-4	8	1005-731-2902	C-5	5
1005-556-4074	C-1	2	1005-777-1370	C-4	-
1005-556-4076	C-1	1	1005-778-0581	C-6	4
1005-556-4174	C-4	8	1005-793-6761	C-6	10
1005-556-4177	C-4	B	4933-508-0340	C-5	4
1005-601-9636	C-2	5	4933-628-9700	C-6	6
1005-601-9652	C-3	1	4933-652-9950	C-5	7
1005-601-9662	C-2	8	4933-726-6450	C-5	8
1005-601-9680	C-1	S	5305-990-6435	C-6	2
1005-610-8828	C-4	4	5315-502-2238	C-2	2
1005-614-7490	C-2	4			

Reference No.	Mfg Code	Fig No.	Item No.	Reference No.	Mfg Code	Fig No.	Item No.
5022202	19205	C-3	3	6147490	19205	C-2	4
5022238	19204	C-2	2	6528362	19205	C-4	7
5153128	19205	C-1	6	7149749	19204	C-5	1
5153130	19205	C-2	1	7162547	19206	C-4	5
5506573	19204	C-4	1	7228907	19205	C-4	2
5507913	19205	C-5	2	7266109	19205	C-5	8
5509090	19204	C-8	2	7266110	19204	C-5	9
5559738	19205	C-4	3	7266115	19204	C-5	10
5564074	19205	C-1	2	7266450	19205	C-5	8
5564076	19205	C-1	1	7267819	19205	C-1	4
5564174	19204	C-4	8	7268211	19205	C-5	4
5564177	19205	C-4	6	7312902	19205	C-5	5
5910521	19204	C-6	-	7790138	19205	C-5	6
6019636	19205	C-2	5	7790352	19205	C-5	7
6019652	19204	C-3	1	7790809		C-6	1
6019662	19205	C-2	3	7790904	19205	C-6	4
6019680	19205	C-1	3	7791237	19205	C-6	8
6108828	19206	C-4	4	7791415	19205	C-6	2

By Order of the Secretary of the Army:

Official:

W. C. WESTMORELAND,
General, United States Army,
Chief of Staff

KENNETH G. WICKHAM,
Major General, United States Army,
The Adjutant General.

DISTRIBUTION:

To be distributed in accordance with DA Form 12-40, (qty rqr block no. 132) Organizational maintenance requirements for Rifle, Caliber .30, Automatic, Browning, M1918A2.